

CITY OF MERCER ISLAND FAMILY EMERGENCY PREPAREDNESS PLAN



PLAN TO BE SELF SUFFICIENT FOR 7 DAYS



Emergency Preparedness Website
www.mercergov.org/emergencyprep



When a disaster occurs, activate this response plan:

1. Take care of yourself, family, home and pets.

- Dress for safety: heavy soled shoes, leather gloves, hard hat or bicycle helmet, and flashlight.
- Shut off natural gas if you smell gas (see page 12).
- Turn off electrical at circuit box.
- Shut off water at main house valve, or main valve at street.
- Call out of state contact to check on family members and give update.
- Tune in battery operated radio to emergency radio station 710 AM/ 94.5 FM or 88.9 FM (MI station).
- Post **OK/HELP** card in window or front door so it is easily visible from street.

2. Check on your neighbors and be prepared to shelter in place for 7 days.

3. Once your family, pets and neighbors are taken care of and if you are able you can volunteer to assist at the City of Mercer Island by reporting to 9611 SE 36th St. (be prepared to provide identification and/or certification if available):

Emergency Information

Emergency	911
Non-Emergency Police	425-577-5656
Non-Emergency Fire	206-275-7607
Puget Sound Energy	1-888-225-5773
Emergency Radio Stations	KIRO 710AM MI High School 94.5FM
Emergency Operation Center	206-275-7600
Volunteer Meeting Place	MI City Hall 9611 SE 36 th St.
Mercer Island Ham Radio	147.160

Emergency Preparedness Website: www.mercergov.org/emergencyprep
Facebook: www.facebook.com/mercerislandemergencypreparedness
Twitter: @mercergov

Officer Jennifer Franklin
Emergency Manager / Crime Prevention Officer
206-275-7905
jennifer.franklin@mercergov.org



Personal & Family Disaster Plan

Getting Ready... Month # 1

Enjoy peace of mind. Start preparing today

Conquering the instinct to run

During earthquakes, many people's fight/flight instinct urges them to *run!* - even when they know they should "drop, cover, hold."

Studies show that people in our country tend to be hurt by falling objects, not collapsing structures. If you are on your feet trying to move, you are in danger from toppling bookcases, breaking windows, flying dishes, falling televisions, collapsing fireplaces, or shifting furniture. Safety comes from quickly getting **under** or **beside** something that is taller than you are.

You and your loved ones can learn to resist the instinct to run by *knowing* where safe places are in each room of your home, and by *practicing* getting to them.

✓ Practicing being safe

- ❑ 1. Choose a safe place to go in *each* room and practice quickly moving to that safe place in the:
 - bedrooms
 - bathroom
 - living room
 - play room
 - kitchen
 - garage

Safe places include:

- **under** a sturdy table or desk
- **beside** a sofa
- **beside** a bed
- **under** a work bench
- **sitting against** an inside wall

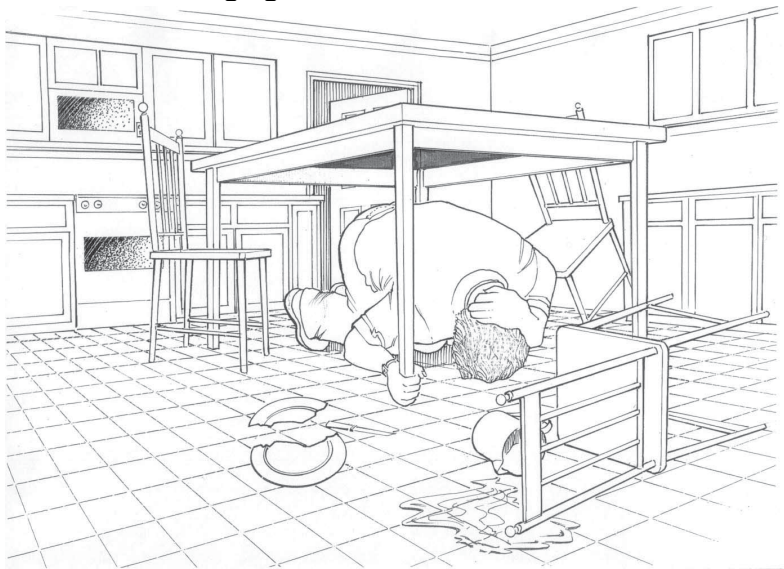
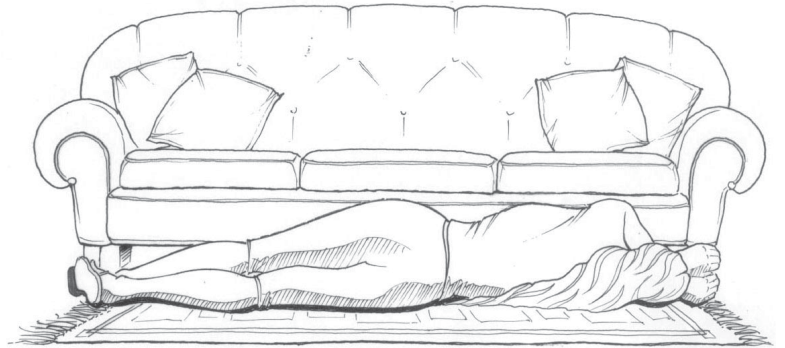

Learn to resist the instinct to run.

Regularly practice:

- Drop - **under** or **beside** something sturdy and taller than you are
 - Cover - the back of your head and neck with one arm
 - Hold on - in case the thing you're under or beside moves
 - Close your eyes - you'll do better psychologically if you don't watch, and you'll protect your eyes
-

Month 1 Personal & Family Disaster Plan						
S	M	T	W	T	F	S
				1	2	3
4	5	6	7	8	9	10
11	12	13	14	15	16	17
18	19	20	21	22	23	24
25	26	27	28	29	30	31

Action is the antidote of worry.

Contacting loved ones after disasters

- 3. Ask an out-of-area friend or relative to be your contact person. This person should live out of Washington or Oregon. See *Did You Know* to find out why you can make long distance but not local calls.

Out-of-area contact:

Phone number:

After a disaster, all household members call this person to tell her or him how they are, and to find out how other household members are.

- 4. Make small cards with this person's name and phone number for all family members to carry in their wallets, purses, or backpacks.

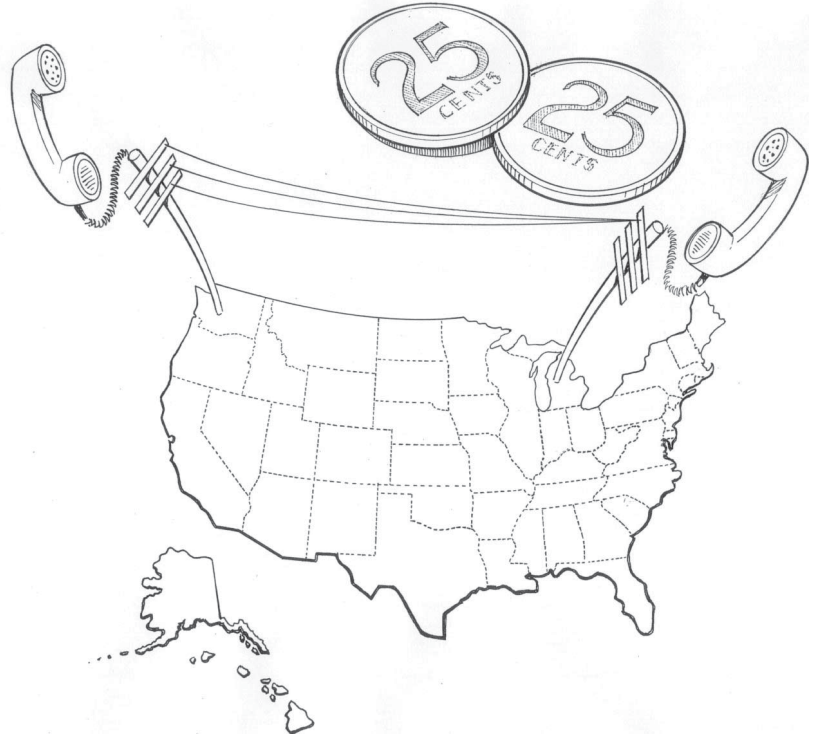

Did You Know

- Phone lines were "hardened" years ago to withstand nuclear attack and are quite resistant to damage. It's difficult to make local calls not because of damage, but because of the number of people trying to call at the same time. Typically, however, you can make long distance calls.
- One reason the local phone system shuts down during earthquakes is because handsets get knocked from their bases. Help restore local phone service by making sure all your phones are hung up.
- You should keep a phone that does not require electricity. Cordless phones use electricity! - if power is out, they will not work.
- Pay phones are part of the emergency services network, and are a priority to be restored to service. Tape the coins needed to use a pay phone to your out-of-area contact card.

Out-of-Area Contact

NAME _____
name of person living out of Washington or Oregon

Contact's phone #'s: _____
daytime / work residence

Fire Meeting Place _____
Near our home

Disaster Mtg Place _____
In case we cannot get home

- Fill out contact cards on page 56
- Distribute to all household members



Storing Water

Getting Ready... Month #2

Enjoy peace of mind. Start preparing today

Preventing thirst after a disaster

Water is essential for survival. The ground trembling and shaking caused by earthquakes can crack or break the lines that bring fresh water to your house. You may have to rely for three days or more on the water you store.

How much water should I store?

Three (3) gallons for each person in your household is the minimum amount required to take care of drinking, cooking, and hygiene needs for the first 72 hours of a disaster.



Which containers are good?

Plastic containers with a screw-cap lid, such as two-liter soda pop bottles or food-grade plastic jugs, work great.

If you use two-liter soda pop bottles, plan to store at least six (6) of these for each person in your household.

Do not use glass bottles or old bleach bottles (or any container that has held a toxic substance). Glass breaks too easily. The plastic of old bleach bottles contains substances that, over time, get into the water and make it unfit for drinking.

Avoid the use of plastic milk jugs. They are difficult to seal tightly, and their plastic becomes very fragile and brittle over time.

✓ Storing water

1. Choose containers that have a tight-fitting screw-cap lid. Two-liter pop bottles are a great choice.

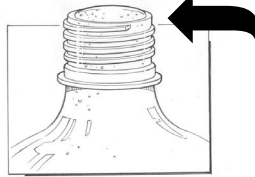

2. Thoroughly rinse out the container with water, and **fill it to the very top** of the container. For extra safety, thoroughly rinse the container with a weak solution of liquid chlorine bleach (8-10 drops in two cups water). Empty this solution out and fill the container right to the top with fresh water.

3. Seal the container tightly.
4. Label it "drinking water" and date it.
5. Store it in a cool, dark place. Examples:
 - under the bed
 - in the corner of closets
 - behind the sofa

Hint: To make it easy to find many places to put your water, think about this activity as a priority rather than an inconvenience.

Can I improve the taste of stored water?

Stored water will taste better if you put oxygen back into it by pouring the water back and forth between two clean containers several times.

Is adding liquid bleach recommended?

In March, 1994, the Food and Drug Administration and the Environmental Protection Agency stated:

- Tap water does not need anything added to it before it is stored because it has already been chemically treated.
- Commercially purchased water does not need anything added to it. Keep it in its original, sealed container.

You will never wish you had not prepared.

S	M	T	W	T	F	S
1	2	3	4	5	6	7
8	9	10	11	12	13	14
15	16	17	18	19	20	21
22	23	24	25	26	27	28
29						

What about rotation?

It is recommended that water be rotated every six months. (When you change your clocks for daylight savings time in the fall and spring is a good time to rotate your water supply.)

Treating water of questionable purity:

1. Filter the water to remove as many solids as possible. Coffee filters, cheesecloth, or several layers of paper towels work well.
2. Bring the water to a rolling boil for a full 10 minutes.
3. Let it cool for at least 30 minutes. Water must be cool or the chlorine you add next will dissipate and be rendered useless.
4. **Add 16 drops of liquid chlorine bleach per gallon** of cool water, or **8 drops per two-liter bottle**. The only active ingredient in the bleach should be 6.00% sodium hypochlorite, and there should be no added thickeners, soaps or fragrances.
5. Let it stand for 30 minutes.
6. If it smells of chlorine, you can use it. If it does not smell of chlorine, add 16 more drops of chlorine bleach per gallon, let it stand for another 30 minutes, and smell it again. If it smells of chlorine, you can use it.

If it does not smell of chlorine, discard it and find another source of water.

Distillation - A second method of purification:

1. Fill a pot halfway with water.
2. Tie a cup to the handle on the pot's lid so that the cup will hang right-side up when the lid is placed upside-down on the pot (make sure the cup is not dangling in the water).
3. Boil the water for 20 minutes. The water that drips from the lid into the cup is distilled.

This method allows the vapor resulting from boiling water to collect in the cup. This condensed vapor will not include salts or other impurities.

Additional information:

- The only thing that should be used to purify water is liquid household bleach containing 6.00% sodium hypochlorite and no thickeners, soaps or scents. Other chemicals, such as iodine or products sold in camping or surplus stores ARE NOT RECOMMENDED AND SHOULD NOT BE USED.
- Boiling water kills bacteria, viruses, and parasites that can cause illness. Treating water with chlorine bleach kills most viruses, but will probably not kill bacteria. Therefore, boiling and then adding chlorine bleach is an effective water purification method.
- The only accepted measurement of chlorine is the drop. A drop is specifically measurable. Other measures, such as "capful" or "scant teaspoon" are not uniformly measurable, and should not be used.
- There is no difference in the treatment of potentially contaminated water that is cloudy or that which is clear.

SOURCE: FDA and EPA Report, 1994

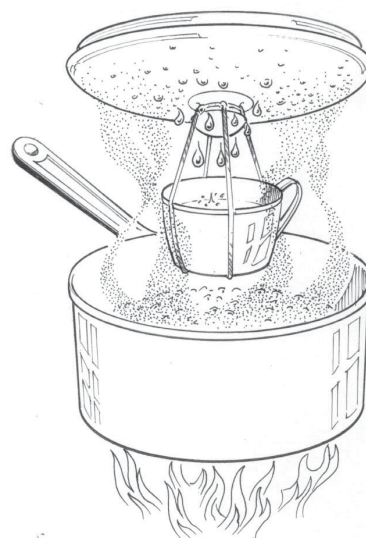

distillation is an effective method of water purification



72-hour Comfort Kits

Getting Ready... Month #3

Enjoy peace of mind. Start preparing today

Storing Emergency Supplies

Chances are you will have to rely upon supplies you have available in your home for at least the first three days following any major disaster. Store these items in something that is portable and easily carried, like a plastic tub with a tight-fitting lid. In the event of fire or rapid evacuation, you'll appreciate having more than just the clothes on your back.

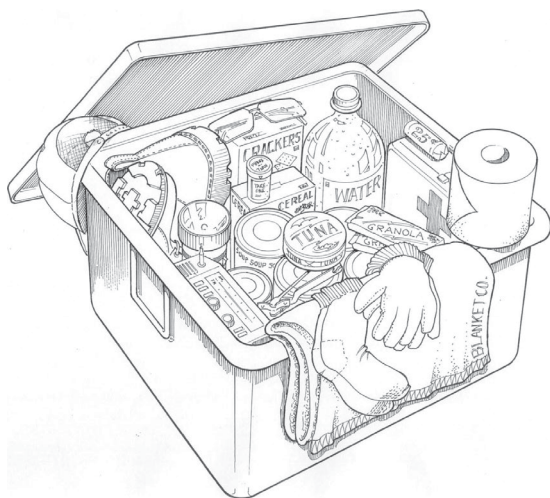

The container should be able to withstand moisture, insects, and some abuse when the quake happens. If you have a large family, several smaller tubs may be easier to carry than one large container.

Place items in plastic bags to protect against condensation, which causes mildew and rust. The bags newspapers come in are a good choice - these can later be used for disposing of waste.

Locate these supplies as close to your primary house exit as possible. You may have to find it in the dark or after the upheaval of an earthquake.

Water

Keep at least a three-day supply of water for each person in your household. Two-liter soda pop bottles work great. That means six two-liter bottles per person. (See pages 6 - 7 for more information on storing an emergency supply of water.)

Food

Store at least a three-day supply of non-perishable food. Select foods that require no refrigeration or cooking, and little or no water.

- canned meats, fruits, and vegetables
- canned juices and soups
- high energy foods - peanut butter, granola bars, trail mix, beef jerky
- "comfort" foods - cookies, hard candy, etc.

First Aid Supplies

- sterile 4" adhesive bandages
- sterile 4" x 4" gauze pads
- 4" rolled gauze bandages
- large triangular bandages
- butterfly bandages
- adhesive tape
- scissors and tweezers
- moistened towelettes
- bar soap
- latex gloves
- aspirin & non-aspirin pain reliever
- antacid
- anti-diarrhea medication
- insect repellent
- hydrogen peroxide to disinfect wounds
- antibiotic ointment to dress wounds
- sunscreen
- safety pins
- needle & thread
- plastic bags
- sanitary pads
- instant cold packs
- pocket knife
- splinting materials

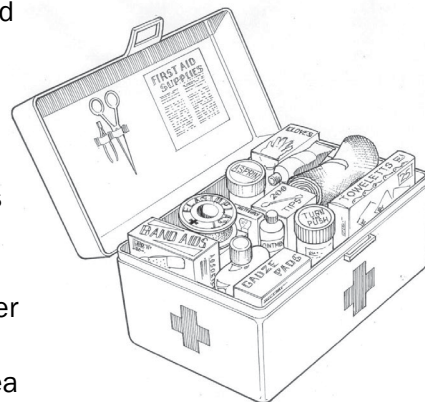

use a film canister to store an extra pair of latex gloves in the car glove compartment

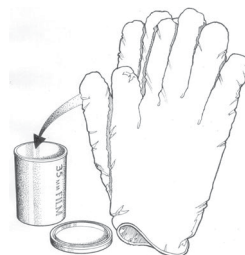

Month 3 72-Hour Comfort Kits						
S	M	T	W	T	F	S
	1	2	3	4	5	6
7	8	9	10	11	12	13
14	15	16	17	18	19	20
21	22	23	24	25	26	27
28	29	30	31			

Effective preparedness is a process.

Preparing for disasters is a long-term goal. To make this task manageable, choose just two or three items that you will get each month.

Tools & Supplies

- paper cups, plates, and plastic utensils
- battery-operated AM radio
- flashlight
- extra batteries
- non-electric can opener
- ABC fire extinguisher
- whistle
- toilet paper and towelettes
- liquid soap
- feminine supplies
- roll of plastic and duct tape to seal broken windows
- heavy duty, large plastic bags



Special Items

- extra eye glasses
- prescription drugs and medications
- baby diapers, food, and formula
- a family picture
- games and books
- copies of insurance policies
- bank account numbers
- inventory of valuables
- family records
- contact lens solution
- denture adhesive
- cash

Clothing & Bedding

- one complete change of clothes
- blankets or sleeping bags
- mylar blankets
- sturdy shoes
- warm socks
- hat and gloves
- jacket

Month #1 items to buy

Item #1 _____

Item #2 _____

Month #2

Item #1 _____

Item #2 _____

Month #3

Item #1 _____

Item #2 _____

Month #4

Item #1 _____

Item #2 _____

Month #5

Item #1 _____

Item #2 _____

Month #6

Item #1 _____

Item #2 _____

Plan to rotate the items in your kit annually. This includes making sure the clothes you have stored still fit!



Enjoy peace of mind. Start preparing today

Framed pictures - securing them helps prevent cut feet

The ground swells and rolls of major earthquakes easily can knock heavy pictures and mirrors off the walls. This can be especially dangerous in the night if these unsecured items are located close to your bed, or during the day if they are located close to your favorite chair or sofa.

Cut feet from broken framing glass and mirrors is one of the most common injuries resulting from major earthquakes. Securing your pictures helps prevent this common injury.

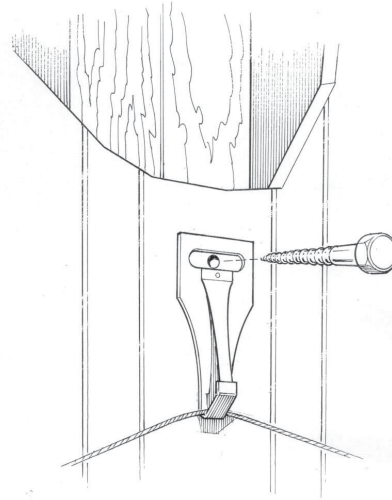

picture hanging hooks that actually close are also a good choice for securing pictures

□ Securing artwork, pictures, and mirrors

- Use a stud finder to find the closest wall stud.
- Screw a screw hook into the wall stud so that there is barely enough room to slide the framing wire between the wall and the hook. This will help prevent the wire from jumping off the hook during the potentially violent movement of an earthquake.
- If the artwork or mirror is large and / or heavy, you may want to consider securing it to two wall studs.
- Secure the bottom corners of these items with Quake-Hold™-type products to keep them from banging against the wall. This helps keep the framing glass from breaking and damaging the artwork or photo.

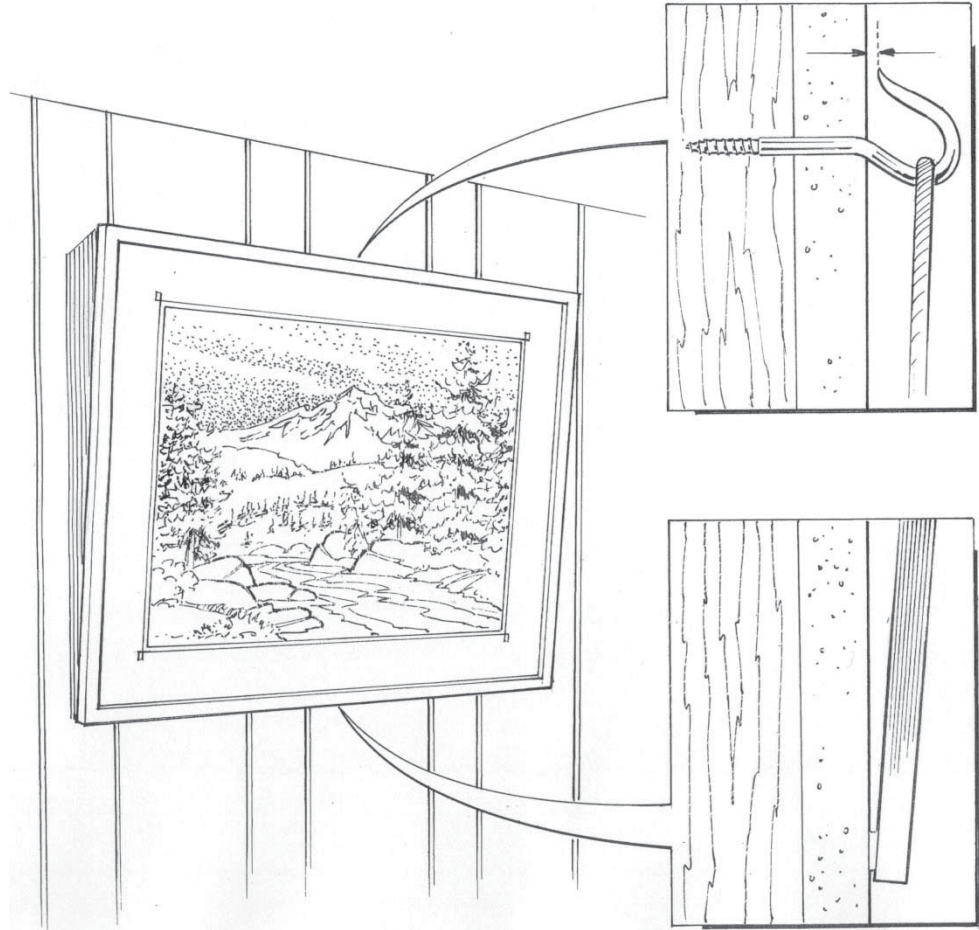

screw hook into wall, leaving just enough space to slide the wire onto the hook

secure bottom corners with Quake-Hold™ or similar product

Month 4 Securing Hanging Furnishings						
S	M	T	W	T	F	S
4	5	6	7	8	9	10
11	12	13	14	15	16	17
18	19	20	21	22	23	24
25	26	27	28	29	30	

Regret and fear are the twin thieves that rob us of today.

Securing hanging objects

Carefully check the location of all hanging plants and other objects. Determine if these objects are close enough to windows to strike them in the wild motion of an earthquake. If they are, consider moving them.

- Find the ceiling stud by using a stud finder.
- Screw the hook directly into the ceiling stud.
- Hang the object from this hook.
- Close the opening in the hook with a pair of pliers to prevent the object from leaping off the hook during an earthquake.

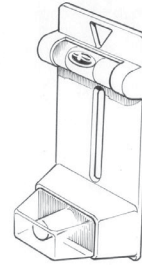

example of a stud finder

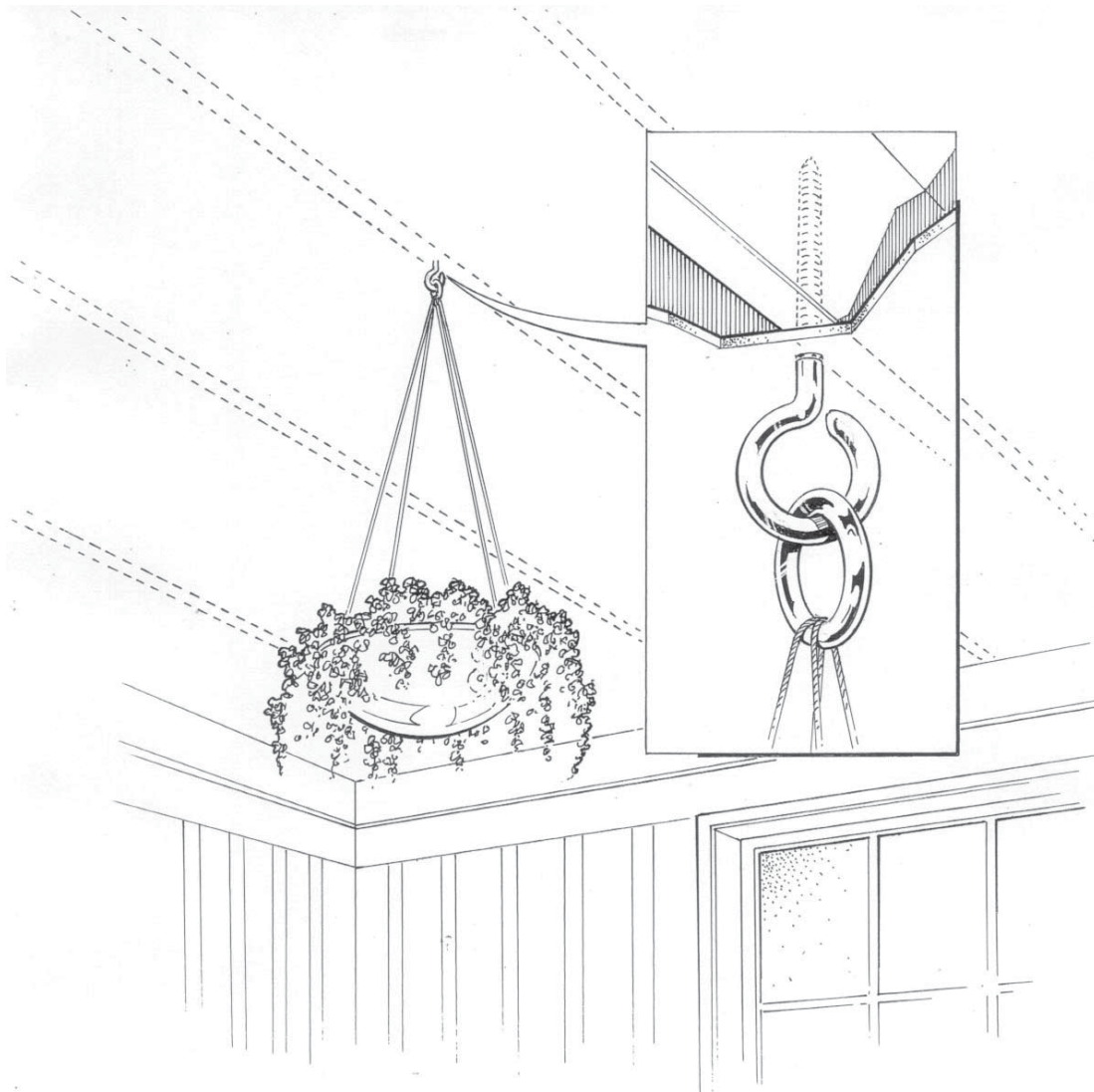



Enjoy peace of mind. Start preparing today

Natural gas

Natural gas leaks and explosions are responsible for a significant number of fires following any major earthquake. It is vital that all household members know how to shut off the natural gas.

□ Preparing to shut off the natural gas

- If you need to shut off the natural gas after an earthquake, turn the valve 90 degrees, or 1/4 turn, so that it crosses the pipe (see illustration) One of your home preparedness efforts should be to check this valve to make sure it will turn. If your valve is rusted open, do not put WD-40™ lubricant on it. It may corrode the O-rings that allow the valve to turn.

CAUTION *If you accidentally turn the gas off while practicing, you **must** call a qualified gas representative to come and turn it on for you. Turning it on yourself will create a gas leak in your home.*

- Attach a wrench to the meter or to the wall directly behind the meter.

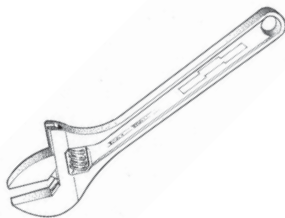

- choose a crescent wrench that is at least 12" long
- adjust it to fit your valve before hanging it behind the meter in case it rusts

Shutting off the gas after an earthquake

- Shut off the gas immediately **only** if you smell the characteristic odor of gas, you hear a hissing sound, and/or you notice the meter dials spinning more rapidly than normal.
- Do not use matches, lighters, open flame appliances, or operate any electrical switches until you are sure no gas leaks exist. Sparks from electrical switches could ignite the gas.
- If you smell natural gas, immediately get everyone out of and away from the house. Open the windows and doors to provide ventilation. Shut off the gas at the meter.
- See page 38 for more information.

the shut-off valve is located on the pipe that comes out of the ground

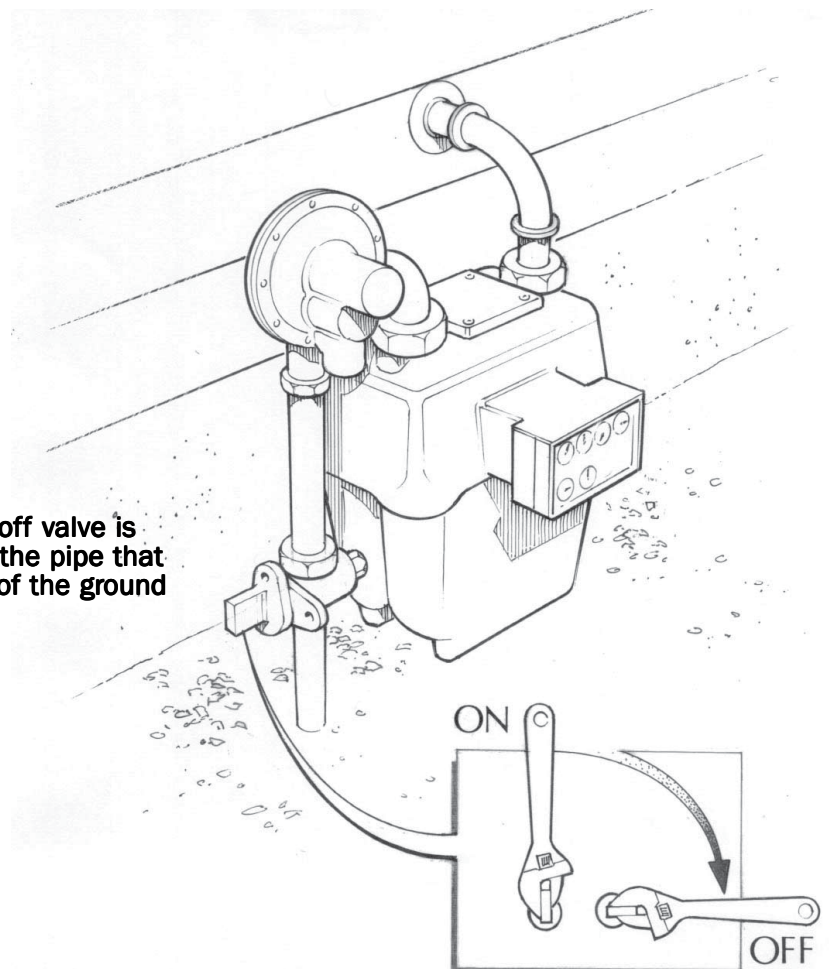

Month 5 Utility Safety						
S	M	T	W	T	F	S
						1
2	3	4	5	6	7	8
9	10	11	12	13	14	15
16	17	18	19	20	21	22
23/30	24/31	25	26	27	28	29

Adversity is opportunity.

Water

Water quickly becomes a precious resource following many disasters. It is vital that all household members learn how to shut off the water at the main house valve.

- Cracked lines may pollute the water supply to your house. It is wise to shut off your water until you hear from the authorities that it is safe for drinking.
- The effects of gravity may drain the water in your hot water and toilet tanks unless you trap it in your house by shutting off the main house valve (not the street valve in the cement box at the curb – this valve is extremely difficult to turn and requires a special tool).

□ Preparing to shut off water

- Locate the shut-off valve for the water line that enters your house. It may look like this:

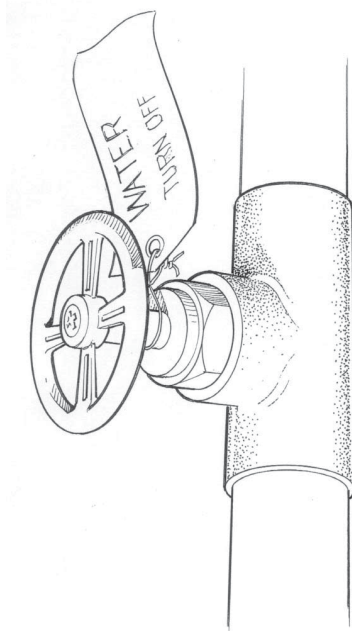

- Make sure this valve can be completely shut off. Your valve may be rusted open, or it may only partially close. Replace it if necessary.
- Label this valve with a tag for easy identification, and make sure all household members know where it is located.

Electricity

Electrical sparks have the potential of igniting natural gas if it is leaking. It is wise to teach all responsible household members where and how to shut off the electricity.

□ Preparing to shut off electricity

- Locate your electricity circuit box.
- Teach all responsible household members how to shut off the electricity to the entire house.

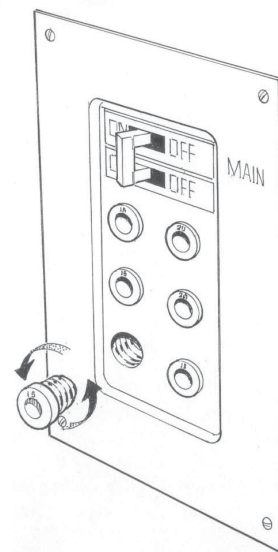
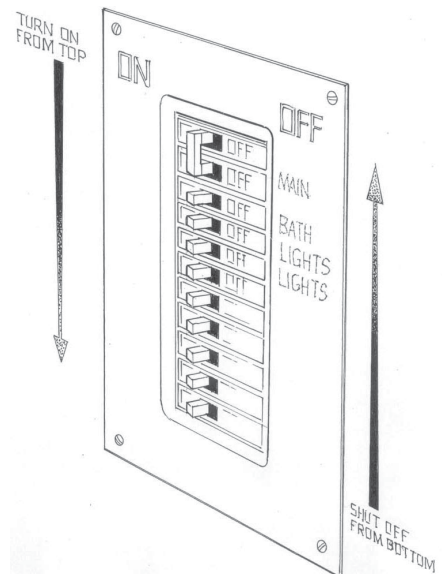

FOR YOUR SAFETY: Always shut off all the individual circuits before shutting off the main circuit breaker.



Enjoy peace of mind. Start preparing today

Earthquakes: A Sudden Release of Energy

The forces that create earthquakes cause the earth literally to quake, producing:

- **ground swells and rolls** from a few inches to a few feet in height, and
- **ground shaking** from a few seconds to a few minutes in duration.

Tall pieces of furniture, such as bookcases, china hutches, and armoires are very likely to fall when the ground is rolling and shaking. You can prevent them from falling on someone you care about, and save their contents, by completing these simple steps.

□ Securing bookcases & all things tall

1. Secure the furniture item to the wall stud.

- locate the wall studs using a stud finder

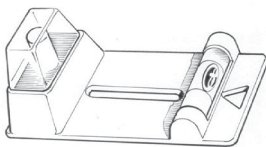

- secure each furniture piece to at least two wall studs, depending on size and weight, using **4" L-brackets and 3" lag screws**, available at all hardware stores



There are commercially available kits utilizing nylon strapping that also are recommended.

2. Place heavy and/or large items on lower shelves to prevent them from flying around the room in an earthquake.

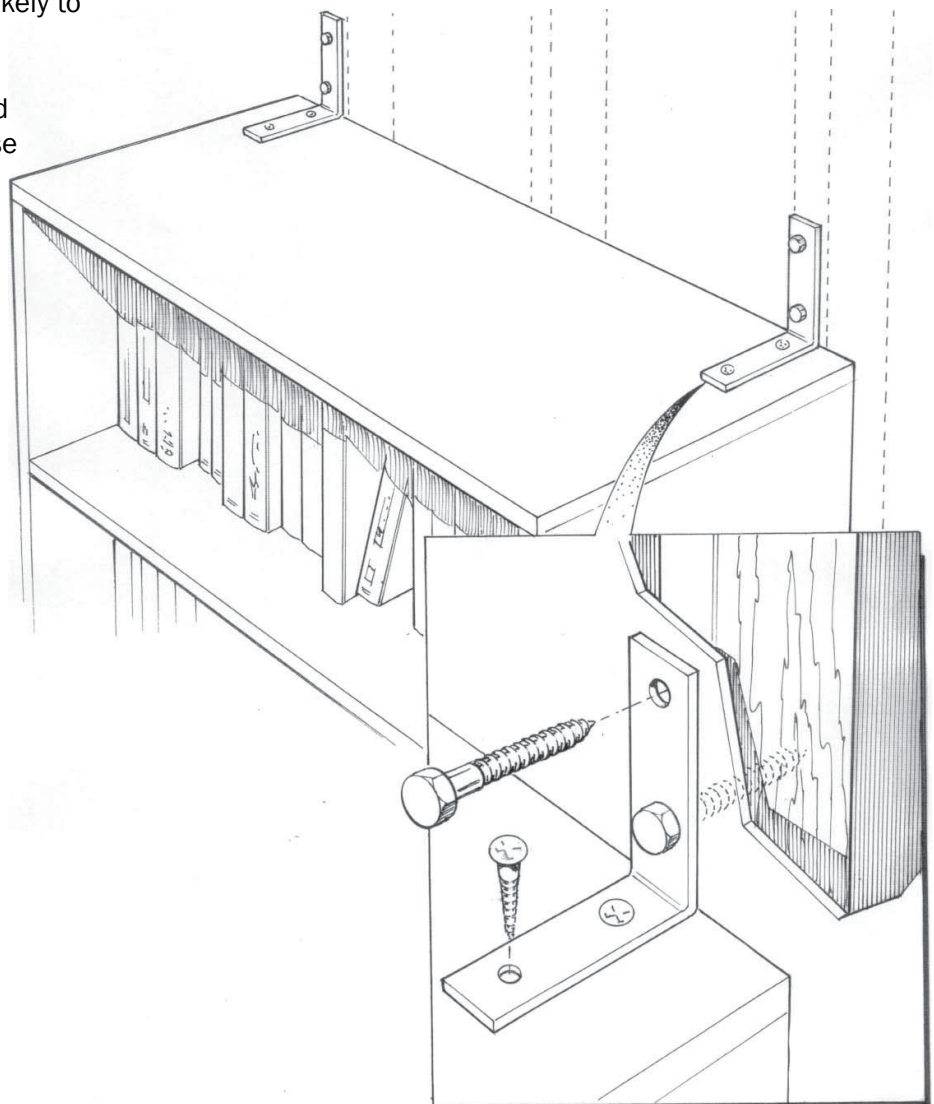

The more you prepare, the more you allay your fears.

S	M	T	W	T	F	S
		1	2	3	4	5
6	7	8	9	10	11	12
13	14	15	16	17	18	19
20	21	22	23	24	25	26
27	28	29	30			

3. The ground swells and rolls of an earthquake can cause anything resting on shelf or counter tops to fall – TVs, stereos, computers, microwaves, lamps, etc. An easy way to protect against these types of losses is to use Velcro™ or other similar products.

- Choose a Velcro™-type product that has adhesive on the back.
- Cut the Velcro™ into large squares. You will need four squares to secure most items, one for each leg or corner of the item.
- Press the two sides of the Velcro™ together.
- Remove the paper from the backs of the Velcro™ to expose the adhesive.
- With the Velcro™ still pressed together, stick it on the legs or corners of the item, and then place the item on the shelf or counter top where you want it located.

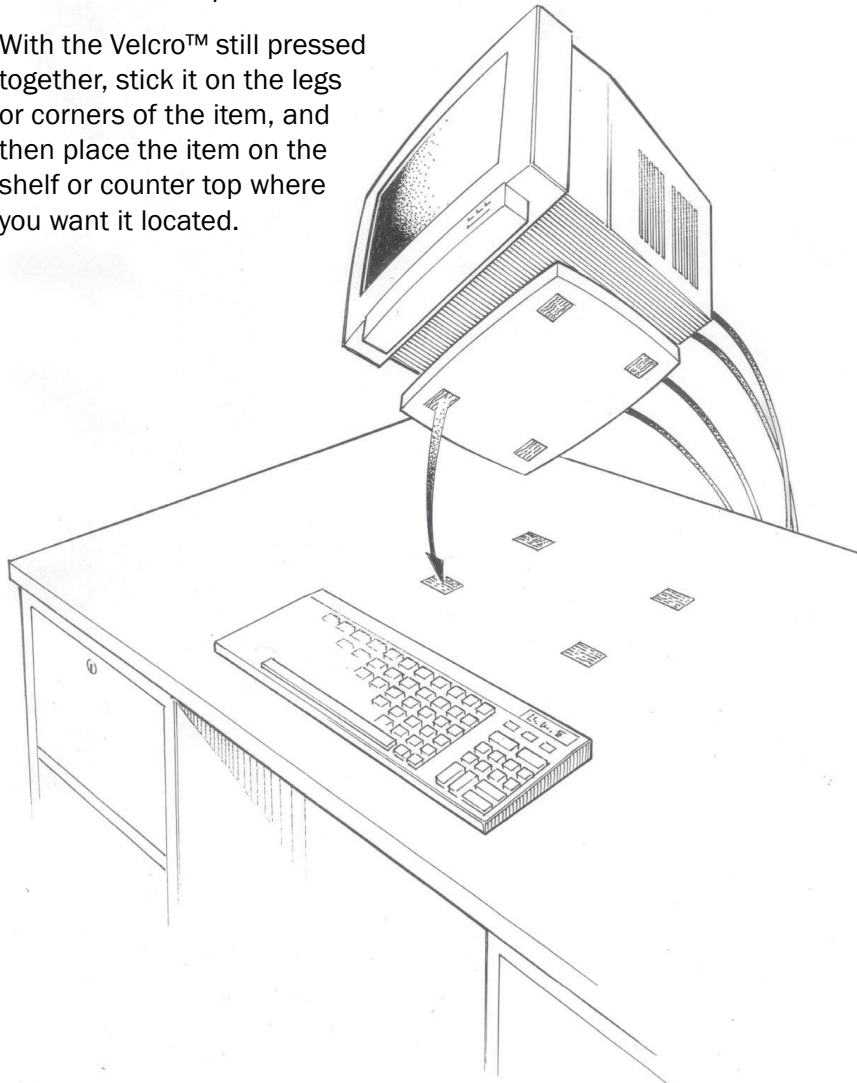

4. More delicate items, like knickknacks, pottery, crystal vases, etc. can be secured with products like Quake Hold™ or Museum Wax™, available at many hardware stores.

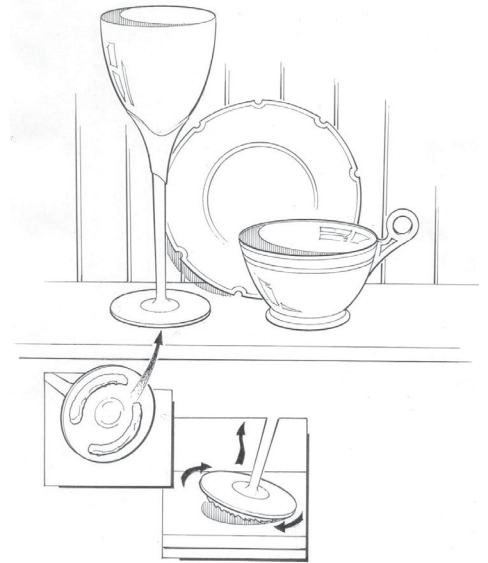



Enjoy peace of mind. Start preparing today

Protected source of water or a puddle

Fresh water after a disaster may be as close as your water heater – provided, of course, that it remains standing upright. A typical water heater holds 30 to 50 gallons of water.

However, this supply of water is extremely vulnerable to the ground undulation (swells and rolls) and ground acceleration of earthquakes, causing them to tip over.

You can protect this valuable resource by securing your water heater to the wall studs.

Changes to strapping recommendations

Experts have modified the recommended procedure for strapping water heaters because many tanks broke through their strapping in both the 1989 Loma Prieta (San Francisco) and the 1994 Northridge (Los Angeles) earthquakes. Experts recommend these two important changes:

- ❑ 1. Secure both the top and the bottom, rather than just the top or just the middle, of the hot water tank.
- 2. Use heavy-gauge metal strapping rather than plumber's tape. Many water heaters in both the 1989 and the 1994 earthquakes broke through the plumber's tape that was intended to keep them secure. Plumber's tape has been found to be too brittle to be effective.

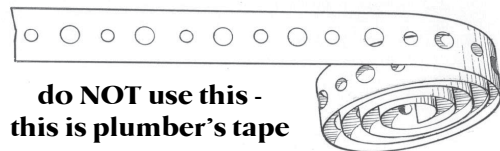

**do NOT use this -
this is plumber's tape
use heavy-gauge
strapping instead**

❑ Securing your hot water tank

Secure your water heater.

- There should be very little space between the water heater and the wall. If there is more than 1 or 2 inches, attach a wooden block to the wall studs with long lag screws (see illustration on page 17). The purpose is to prevent the heater from tipping backwards.
- Wrap the heavy-gauge metal strapping 1 ½ times around the tank. Start by placing the strapping at the back of the tank. Bring it to the front and then take it back to the wall (see illustration). • Secure this strapping to the wall studs or the wood block using several 1/4" x 3" or longer lag screws *with oversized washers*. If you are securing it directly into concrete, use 1/4" expansion bolts in place of the screws.

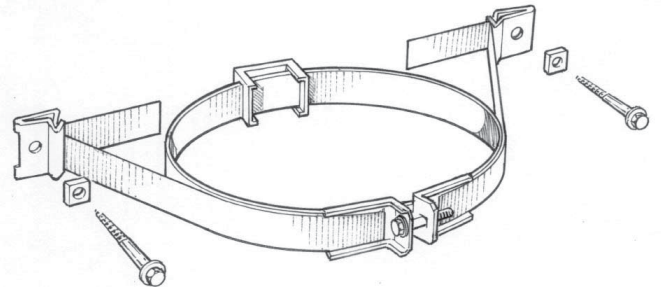

Commercially available kits like this one come complete with the strapping, lag screws, washers, spacers, and tension bolts. These kits can be purchased at many local hardware stores, and are recommended.

- Replace all copper and metal piping with flexible natural gas and water line connectors.

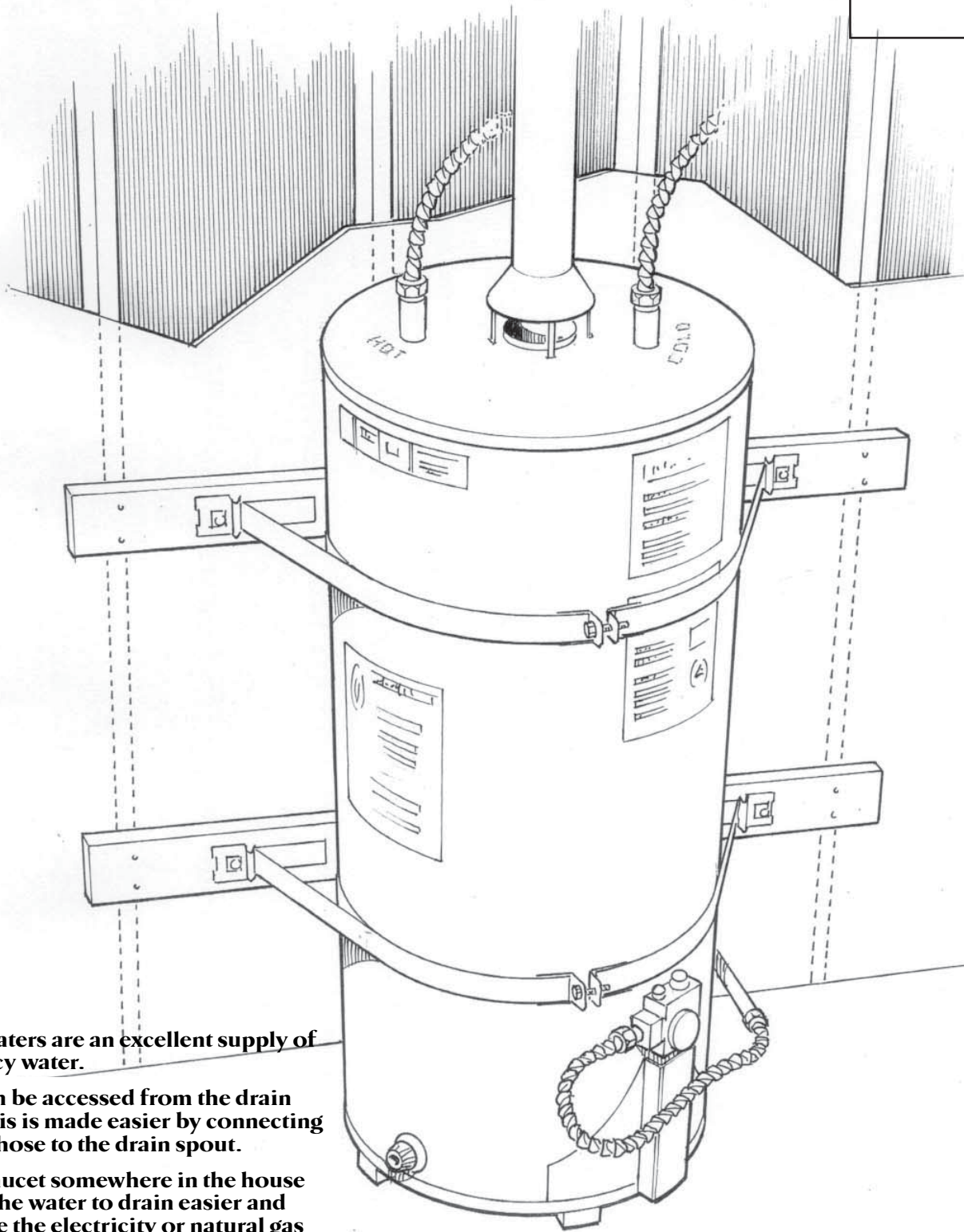

Water heaters are an excellent supply of emergency water.

Water can be accessed from the drain spout - this is made easier by connecting a garden hose to the drain spout.

Open a faucet somewhere in the house to allow the water to drain easier and make sure the electricity or natural gas is shut off before opening the drain.



Enjoy peace of mind. Start preparing today

Choosing comfort over inconvenience

Coping with the impact of a disaster is never fun. However, much of the inconvenience and discomfort the disaster causes can be reduced by planning alternative ways to take care of your needs.

Acquiring emergency supplies

At first glance, the list below may seem totally overwhelming. At second glance, you'll find that you probably already have many of these items.

Y Check those items you already have.

± Circle those you don't have, but are important to the comfort of you and your loved ones.

N Choose two of those circled, and add them to your weekly shopping list.

Lighting

Caution: The use of candles is no longer recommended as a source of emergency light. Experience shows they are responsible for too many secondary fires following the disaster. Additionally, they are very dangerous in the presence of leaking natural gas.

- flashlights and extra batteries
- camping lanterns – store extra fuel, wicks, mantles and matches
- lightsticks – these can provide light for 1 to 12 hours and can be purchased at many camping supply stores

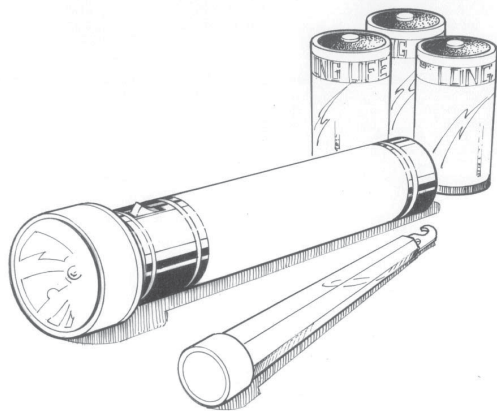

lightstick

Critical under-the-bed items

- sturdy shoes - keep a pair near the bed to protect your feet from broken glass
- work gloves, preferably leather, to protect your hands from broken glass
- hardhat - to protect you from falling objects
- flashlight & light sticks
- this workbook, the OK / Help card tucked inside, and a few bandaids so that you always have adhesive to hang the OK card in the window following a disaster



Cooking

Caution: Never burn charcoal indoors. This could cause carbon monoxide poisoning.

- camp stoves, sterno stoves, or barbecues – store extra propane, charcoal or sterno, lighter fluid, and matches
- fireplaces – do not use until the chimney and flue have been inspected for cracks. Sparks may escape into your attic through an undetected crack and start a fire.
- paper plates and cups
- plastic utensils
- paper towels

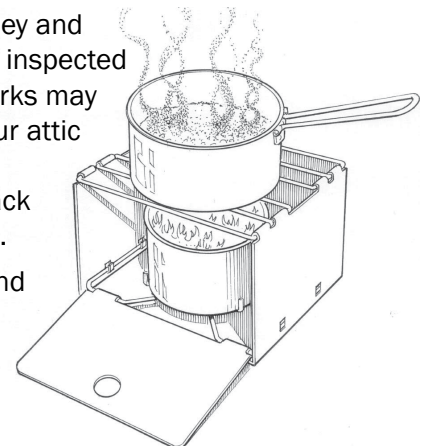

Month 8 Emergency Supplies						
S	M	T	W	T	F	S
1	2	3	4	5	6	7
8	9	10	11	12	13	14
15	16	17	18	19	20	21
22	23	24	25	26	27	28
29	30	31				

Sanitation

The lack of sanitation facilities following major earthquakes can quickly create secondary problems unless basic guidelines are followed. If the water lines are damaged, or if damage is suspected, do not flush the toilet.

Avoid digging holes in the ground and using these. Untreated raw sewage can pollute fresh ground water supplies. It also attracts flies and promotes the spread of diseases.

- Store a large supply of heavy-duty plastic bags, twist ties, disinfectant, and toilet paper.
- A good disinfectant that is easy to use is a solution of one part liquid bleach to ten parts water.

Dry bleach is caustic and not safe for this type of use.

- If the toilet is *not* able to be flushed, it can still be used. This is less stressful for most people than using some other container. Remove all the bowl water. Line bowl with a heavy-duty plastic bag. When finished, add a small amount of deodorant or disinfectant, securely tie the bag, and dispose of it in a large trash can with a tight fitting lid. This large trash can should also be lined with a sturdy trash bag. Eventually, the city will provide a means to dispose of these bags.
- Portable camp toilets, small trash cans, or sturdy buckets lined with heavy-duty plastic bags can be used. Those with tight fitting lids are best.
- Large ziplock plastic bags and toilet paper should be kept at work and in the car for use if you are away from home. These can be wrapped in newspaper in preparation for future disposal.

Fear is the penalty of unpreparedness.

Shelter

It is common for people to not want to sleep in their homes for the first few days following a major earthquake. Having an alternate means of shelter will help you and your family be as comfortable as possible.

- tent or waterproof tarp
- sleeping bags or blankets, and pillows
- rain gear
- mylar blankets are compact and easy to store
- newspapers provide insulation from the cold or heat

Pets

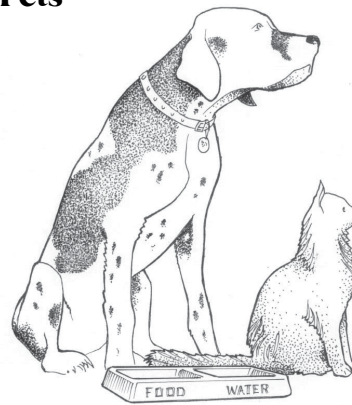

Always keep a week's supply of food and water for your pet on hand.

- toilet bowl water is an excellent supply of water for pets following an earthquake

See page 55 for more preparedness ideas.

Emergency information

Obtain a battery-powered radio and a supply of extra batteries.

The Puget Sound area Emergency Alert System (EAS) stations are:

- KIRO – AM 710
FM 100.7
- KOMO – AM 1000
- KNWX – AM 770
- KVI – AM 570
- KIXI - AM 880
- KLSY - FM 92.5

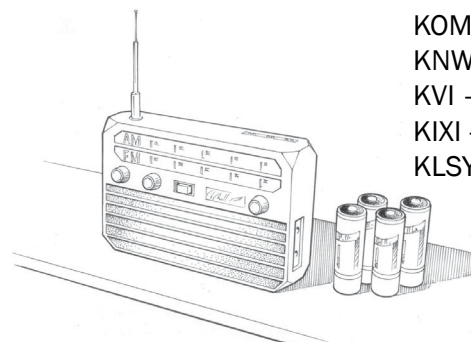



Enjoy peace of mind. Start preparing today

Kitchen Cabinets

The ground undulation and acceleration of an earthquake can cause cabinet doors to fly open and contents to spill onto the floor. Glass jars and dishes can shatter and cause injuries and damage. Heavy objects can fly across the room, injuring any in their path or damaging counter tops, floors, or walls.

□ Securing kitchen cabinets

To prevent cabinet doors from flying open, install one of the following types of latches:

- A. Hook and eye – inexpensive; you may not close it every time
- B. Standard latch – mounts to the front of the door; you may not close it every time
- C. Standard latch – closes automatically; mounts to the front of the door
- D. Push latches – mounts inside the door; holds the door firmly shut; opens by being pushed gently inward
- E. Child-proof – inexpensive; closes automatically; requires an extra action when you open the door; takes some getting used to

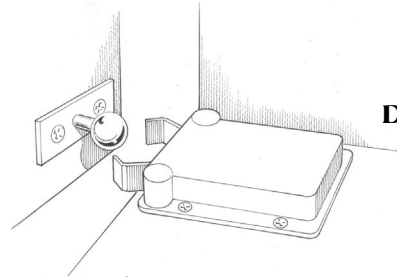

- D. Push latch**
 - mounts inside cabinet
 - opens by pushing gently inward on cabinet door

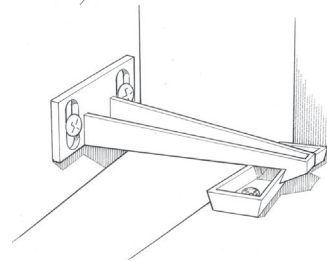

- E. Child-proof latch**
 - inexpensive
 - takes some getting used to – must reach inside cabinet to release latch

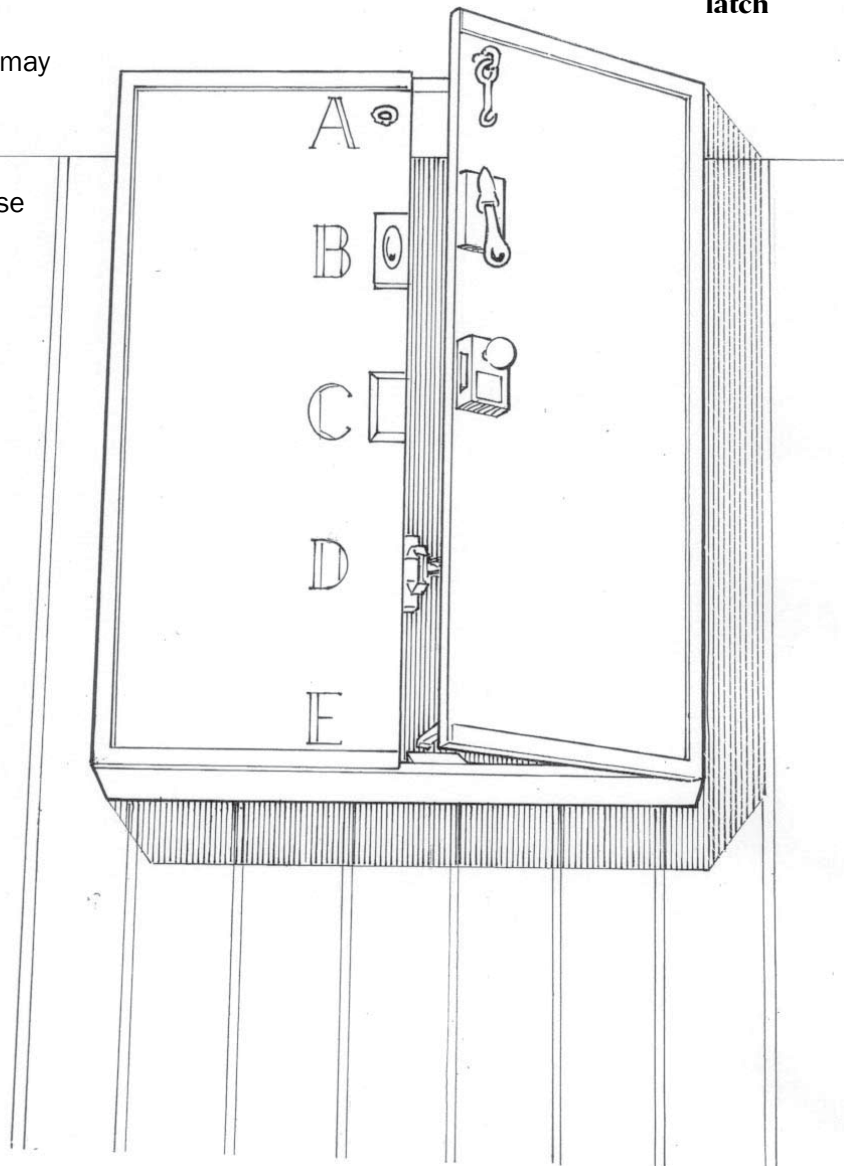

Month 9 Kitchen & Cabinet Safety						
S	M	T	W	T	F	S
5	6	7	8	9	10	11
12	13	14	15	16	17	18
19	20	21	22	23	24	25
26	27	28	29	30		

It costs less to prepare than it does to repair.

Securing cabinet contents

The contents of cabinets may shift and break in the movement of an earthquake. To help prevent this movement, line your cabinets with rubberized shelf mats. This typically is sold in rolls or pre-cut squares at hardware and variety stores. It is also available at recreational vehicle or boating equipment supply stores.

To **protect stacked china plates**, place a square of this rubberized matting between each plate in the stack.

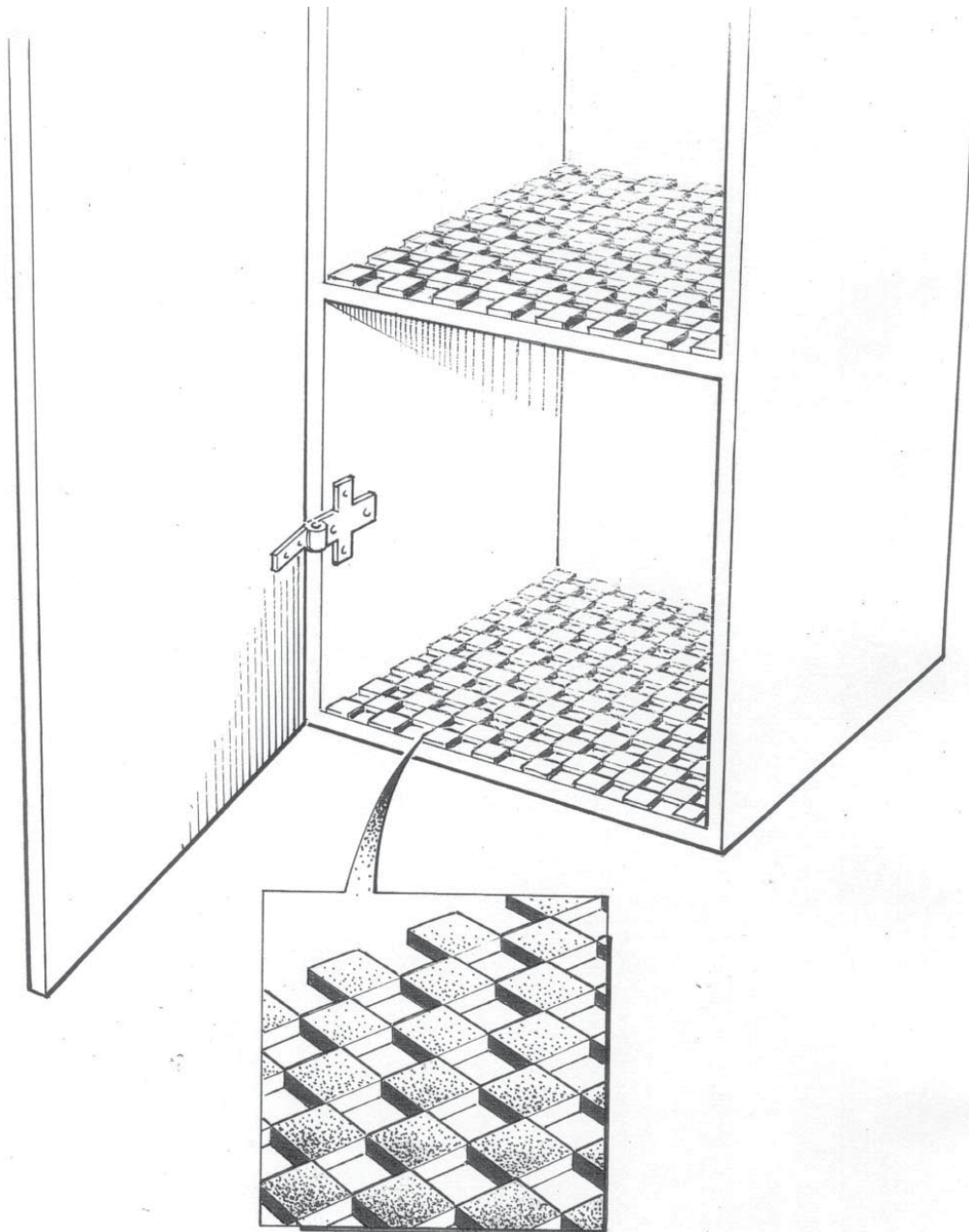



Enjoy peace of mind. Start preparing today

Pre-planning: key to your safety

When it comes to fire – *be smart!* If the fire is too big for you to handle, immediately get out of the house. Don't stop to gather anything or to do anything. Once you are outside, stay outside. Intense heat and toxic fumes can kill you.

□ Planning & practicing fire safety

1. Choose a reunion place outside your home.

Our fire reunion place is: _____

- Regularly remind all household members where this place is.

2. Draw the floor plan of your home, and discuss two ways to exit each room.



3. Hold a fire drill at least twice each year.

Blindfolded, practice crawling your exit routes to simulate getting out of a smoke-filled house.

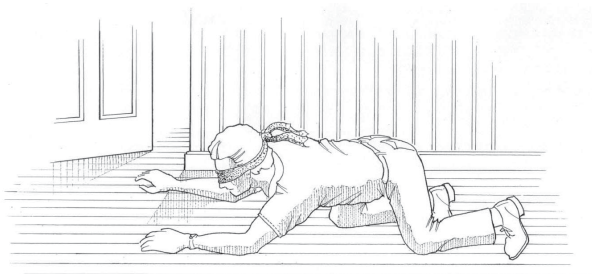

□ Fire extinguishers

- Locate your fire extinguishers with care. Ready access to them is critical. Fire moves quickly – quick access can be the difference between putting a small fire out or suffering much damage.
- Several smaller extinguishers located throughout the house are better than one large one that may be difficult to get to quickly.

Key places for your extinguishers are:

- the kitchen
- garage, and
- one on every level if your home has multiple floors.

• A:B:C extinguishers are recommended:

“A” fires – ordinary combustibles such as wood, paper, cloth, and many plastics

“B” fires – flammable liquids such as gasoline, paints, kitchen grease, and oils

“C” fires – electrical equipment, such as fires in wiring, motors, and appliances

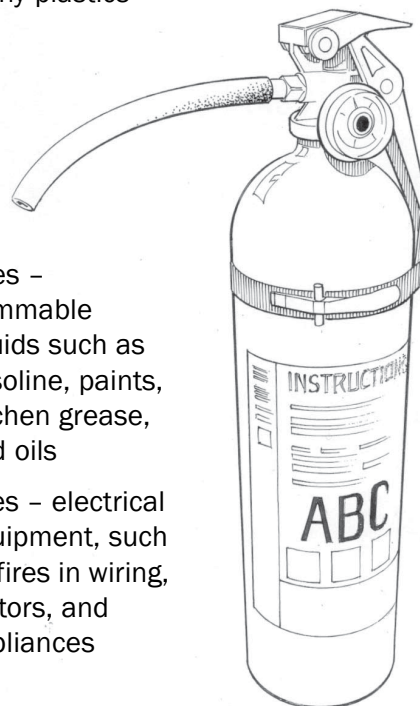

- Check your extinguishers on a regular basis to ensure they are properly charged.

Nothing in life is to be feared - it is only to be understood.

S	M	T	W	T	F	S
3	4	5	6	7	8	9
10	11	12	13	14	15	16
17	18	19	20	21	22	23
24/31	25	26	27	28	29	30

Using a fire extinguisher

- Try to keep calm.
- VITAL: Keep an escape route open between you and the *small* fire you are attempting to extinguish. If the fire is large or becomes too large, immediately get out of the house. Close the door on your way out to slow the spread of flames.
- Always point the extinguisher at the base of the fire rather than at the top of the flames.
- Remember, if the fire is too big for you to handle, immediately get yourself and your family out of the house. Don't stop to gather anything or to do anything. Seconds can make all the difference.
- Once you are outside, stay outside. Intense heat and toxic fumes can kill you in seconds.

Possible fires following earthquakes

- **Natural gas fires** –

First, shut off the gas.

Second, put the fire out by using an extinguisher, dirt, or water.

- **Electrical fires** –

First, shut off the electricity.

Second, put out the fire by using an extinguisher, or dirt, or water.

(CAUTION: If the electricity cannot be shut off, DO NOT use water on the fire.)

- **Oil or grease fires** –

Do not move the pan. Turn off the heat. Use a lid, a bread board, or a fire extinguisher to smother the flames. NEVER use water on a grease or an oil fire.

P.A.S.S. - a proven and effective system for putting out fire

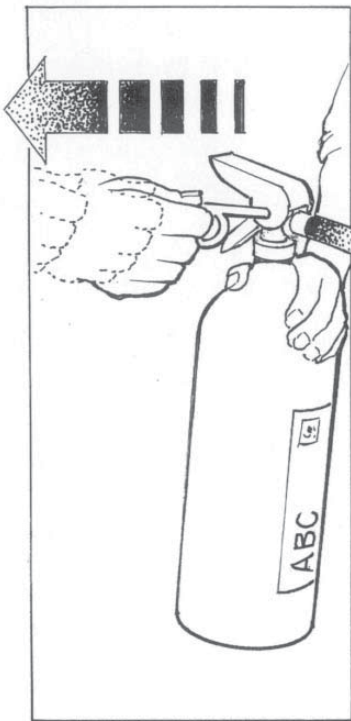

P. Pull the pin.

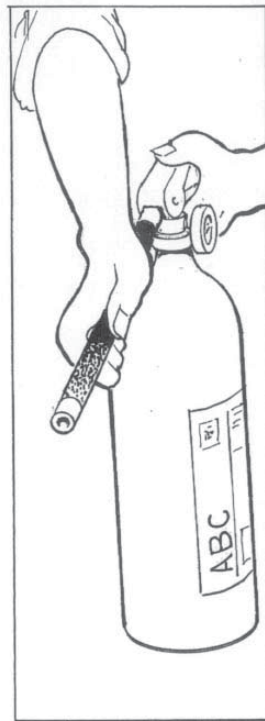

A. Aim at the base of the fire.

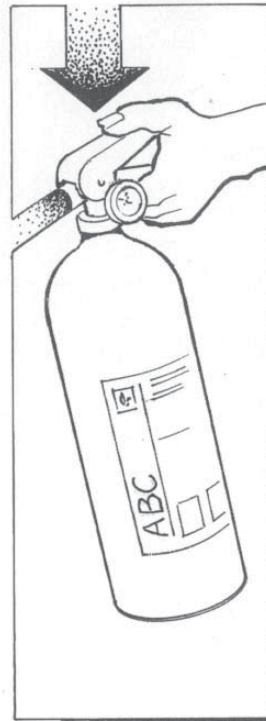

S. Squeeze the handle.

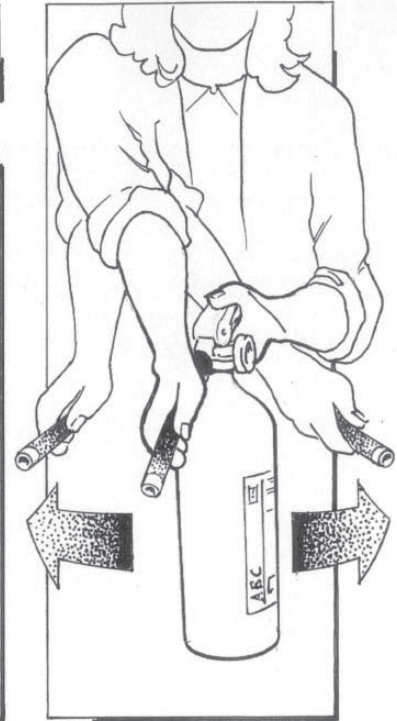

S. Sweep the hose side to side.

Start at least 6 feet back from the fire and move closer as you put the fire out.



Enjoy peace of mind. Start preparing today

Household chemicals - potentially lethal

The ground movement of earthquakes can cause chemical products you have stored in the garage and under household sinks to spill and potentially mix. These materials can be silent killers or can cause serious injury.

□ Before a disaster - safety with chemicals

Secure all chemicals so that they cannot fall, break, and mix.

- Identify poisons, toxins, and solvents in breakable containers on open shelves.
- Remove all heavy objects from upper shelves, especially around the car.
- Secure open shelves with nylon webbing (available at hardware stores, boating supply stores, and many camping supply stores) or bungee-type straps. (Do not use regular bungee straps with the heavy metal hooks at either end. These may become dislodged and cause serious eye or other injuries.)
- Store paints, gasolines, and other flammable liquids away from natural gas water heaters.
- Read the labels on all products you purchase.
- Separate the chemicals according to manufacturers' suggestions to prevent harmful interactions if broken containers should allow the chemicals to mix. For example, household bleach mixed with ammonia creates extremely deadly chlorine gas.
- Know what steps to take if chemicals are spilled.
- Dispose of any hazardous materials that are no longer used.

□ After a disaster - safety with chemicals

- Always assume that spilled chemicals are toxic.
- Do not immediately approach spilled chemicals in your haste to clean them up. Mixed chemicals can be extremely hazardous.
- Close off the room where the spill has occurred.
- Mark the outside of the room with the problem, for example, "spilled chemicals inside - use caution."
- Notify your Block Coordinator of the spill. Have the Block Coordinator instruct the Communications Team to report this to the amateur radio operators in your neighborhood.

Ways hazardous materials enter the body:

- inhalation (breathing) - the most common way
- absorption - through skin or eyes
- ingestion - swallowing
- injection - penetrating the skin or falling on something that punctures the skin

Indicators that a spill has taken place

- pungent or noxious odor - never intentionally get close enough to smell it
- bubbling liquid
- vapor - anything that is releasing a vapor is having a chemical reaction and should be avoided

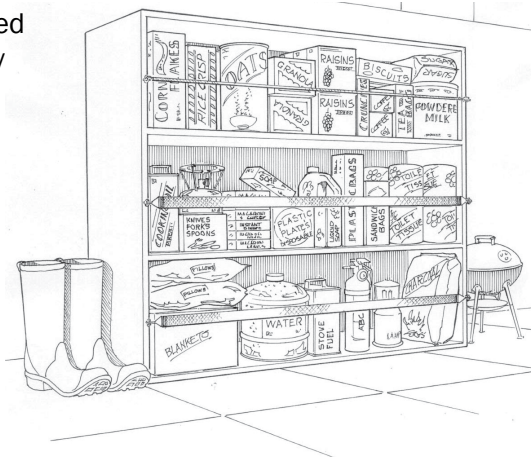

Effective preparedness is a process.

S	M	T	W	T	F	S
	1	2	3	4	5	6
7	8	9	10	11	12	13
14	15	16	17	18	19	20
21	22	23	24	25	26	27
28	29	30				

□ Protecting stored foods when the power goes out

- Keep refrigerator and freezer doors closed as much as possible.

A full refrigerator will maintain safe temperatures for up to six hours.

A full freezer will maintain safe temperatures for up to two days; a half-full freezer for one day.

Discard at-risk refrigerated foods that are warmer than 45° Fahrenheit. If in doubt, throw it out.

- If you think the power will be out for several days, try to find some ice to pack inside the refrigerator and freezer.

Remember to keep your raw foods separate from your ready-to-eat foods.

Foods to be concerned about

- Foods are categorized into groups:
 - Potentially hazardous foods** are the most important. These include meats, fish, poultry, dairy products, eggs and egg products, soft cheeses, cooked beans, cooked rice, cooked potatoes, cooked pasta, custards, puddings, etc.
 - Some foods **may not be hazardous** but the quality may be affected. These foods include salad dressings, mayonnaise, butter, margarine, produce, hard cheeses, etc.
 - Some foods are **safe**. These are carbonated beverages, unopened bottled juices, ketchup, mustard, relishes, jams, peanut butter, barbecue sauces, etc.

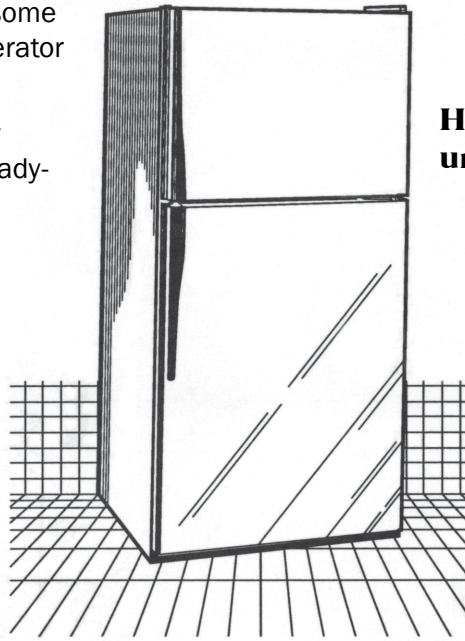

When do I save and when do I throw out food?

- Refrigerated foods should be safe as long as the power is out no more than a few hours and the doors have been kept closed. **Potentially hazardous foods** should be discarded if they warm up above 45°F.
- Frozen foods which are still frozen are not a problem.

If **potentially hazardous foods** are thawed but still have ice crystals, you should use them as soon as possible.

- If potentially hazardous foods are thawed and warmer than 45°F, you should discard them.

How do I know if the food is unsafe to eat?

- You cannot rely upon appearance or odor. Never taste food to determine its safety.
- Some foods may look and smell fine, but if they've been warm too long, food poisoning bacteria may have grown enough to make you sick.
- If possible, use a thermometer to check the temperature of the foods. If potentially hazardous foods are colder than 45°F, they are safe.

What happens when the power goes back on?

- Allow time for refrigerators to reach the proper temperature of lower than 45°F before restocking. Start with all fresh foods.

**Remember -
when in doubt,
throw it out.**



Enjoy peace of mind. Start preparing today

Wood-framed homes – safe & sound?

Homes that have been framed in wood are generally quite resistant to earthquake damage. While it is unlikely that conventionally framed houses will collapse, your assurances of safety are dramatically improved if the home remains on its foundation, and the roof, ceiling, and walls remain connected. If you have specific questions about your home, please contact an engineer experienced in seismic strengthening. Structural Engineers can be found in the yellow pages of the phone book.

Securing your foundation

The majority of residential structural damage is caused by homes sliding off their foundations during major earthquakes.

- Check your house and garage for foundation bolts. These bolts secure the wood structure to the concrete foundation. They should be placed every six feet along the sill plate.
- Using a hammer drill and a carbide bit, drill a hole through the sill plate into the foundation. Place these holes every six feet.
- Drop a 1/2" x 8" expansion bolt into the hole and tighten the nut.

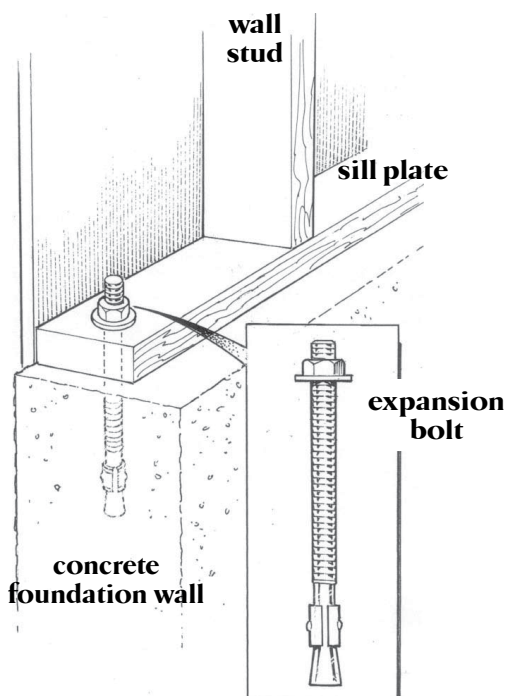

Cripple walls

- Inspect the vertical studs that extend from the foundation to the first floor of your home. These are common in crawl space areas and are called cripple walls. If they are exposed (for example, without sheathing) on the inside, they could buckle in the ground motion that accompanies many large earthquakes.
- Strengthen the cripple walls by nailing plywood sheathing to the vertical studs, sill plate, and top plate.

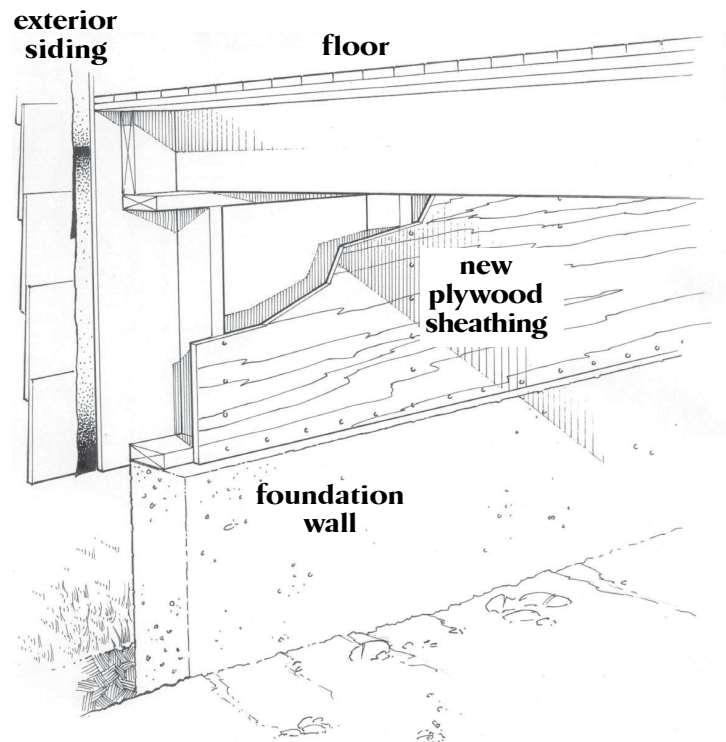

CAUTION: Retrofitting done improperly may actually cause damage to your home during an earthquake.

These pages are intended to illustrate the types of structural retrofitting houses need to be seismically safe. They are NOT intended to provide the specific directions on how to do the retrofitting.

Call the Bellevue Planning & Community Development Dept. at 425-452-4570 for complete instructions.

Month 12 Structural Mitigation						
S	M	T	W	T	F	S
5	6	7	8	9	10	11
12	13	14	15	16	17	18
19	20	21	22	23	24	25
26	27	28	29	30	31	

Preparedness, when properly pursued, is a way of life - not a sudden, spectacular program.

☐ Strengthening the frame

For a building to stay together in an earthquake, all its parts must be fastened together. Commercially available metal connectors are used to strengthen places where beams, posts, walls, the floor, and the ceiling join.

- Strengthen the connections between ceilings, walls, and floors using the appropriate hardware:

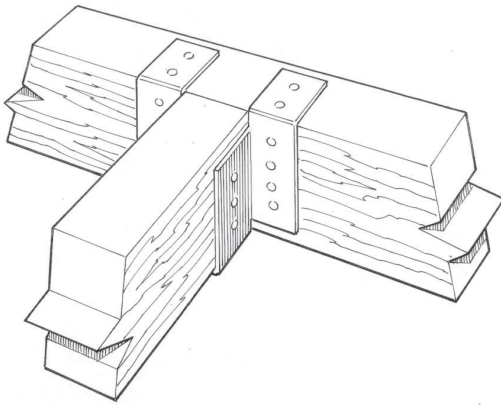

- Inspect all exposed framing in garages, basements, porches, and patio covers. Strengthen this where necessary.

☐ Brick & masonry facades

- Check all brick, masonry, and stone facades to make sure they are securely attached to your home. Consult a structural engineer for advice on how to do this.

CAUTION: Retrofitting done improperly may actually cause damage to your home during an earthquake.

These pages are intended to illustrate the types of structural retrofitting houses need to be seismically safe. They are NOT intended to provide the specific directions on how to do the retrofitting.

Call the Bellevue Planning & Community Development Dept. at 425-452-4570 for complete instructions.

☐ Chimney

One of the most common types of damage suffered in earthquakes is a toppled chimney. This becomes extremely dangerous when bricks penetrate the roof and fall to the rooms below.

- Check the chimney for loose tiles and bricks.
- Reinforce the ceiling surrounding the chimney with 3/4" plywood nailed to the beams. This provides protection from falling bricks that might break through the roof.

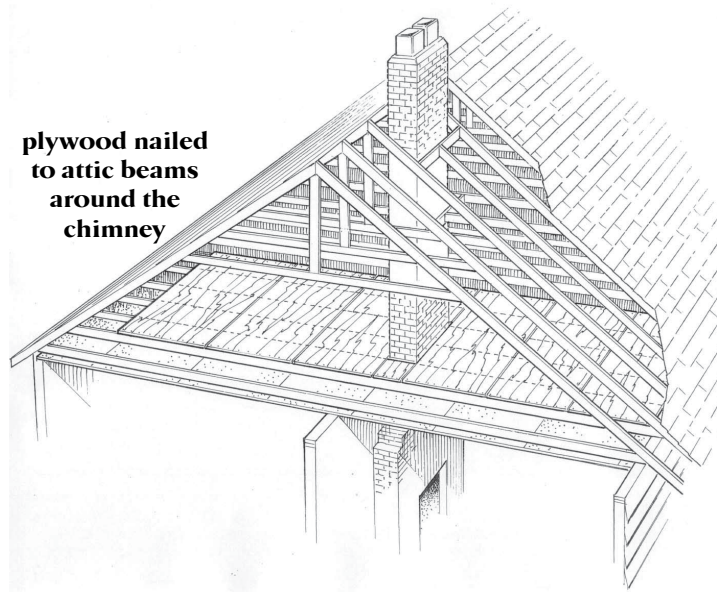

- If your chimney is old and extends more than five feet above the roof, consider bracing it. Check the yellow pages in the phone book for engineers who are experienced in seismic strengthening.

☐ Windows

- Inspect all large plate glass windows to make sure they are safety glass.
- Consider adding a safety film to all windows. This does not prevent the window from breaking, but it does keep the glass from falling and injuring loved ones.



Making an Emergency Stretcher

Making a Stretcher

You may need to transport injured neighbors to the First Aid Station. A stretcher made from a blanket and two poles is a relatively easy way to do this.

Poles can be purchased at any hardware store (closet poles work great).

Procedure

1. spread the blanket out on the ground
2. place the two poles on top of the blanket about 18 inches apart in the middle of the blanket
3. fold one edge of the blanket so that it **crosses or covers both poles**
4. fold the other edge of the blanket so that it **also crosses over both poles** and rests on top of the previous fold

If the blanket has been folded over both poles both times, the weight of the person will keep the blanket securely in place.

Alternate stretcher

- stuff a ladder with pillows

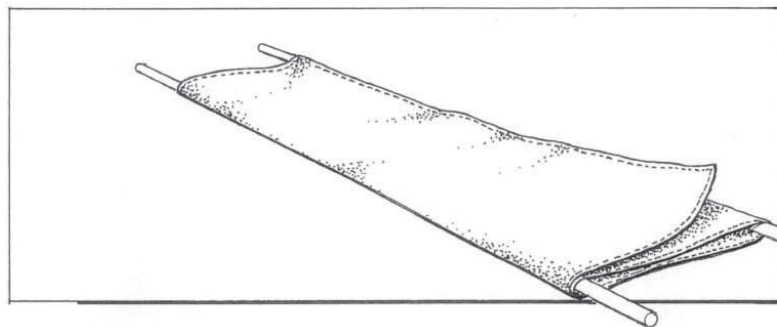
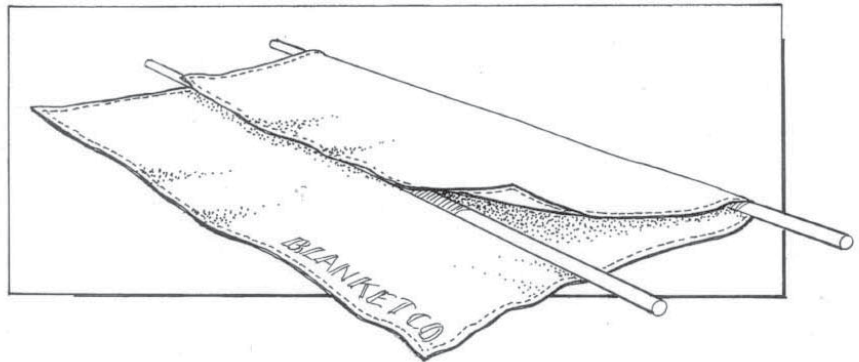
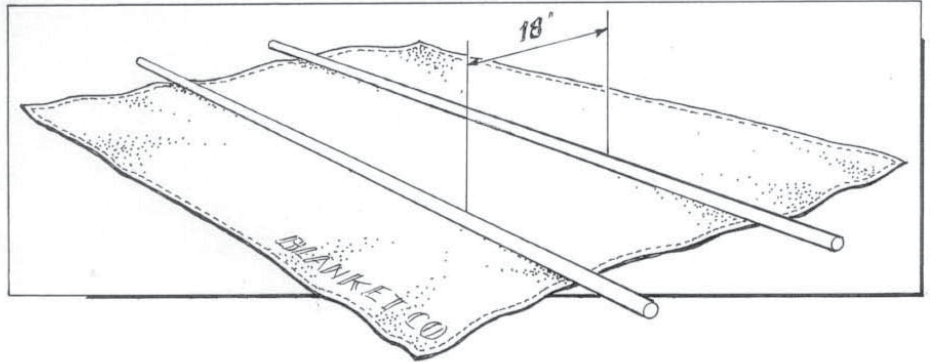
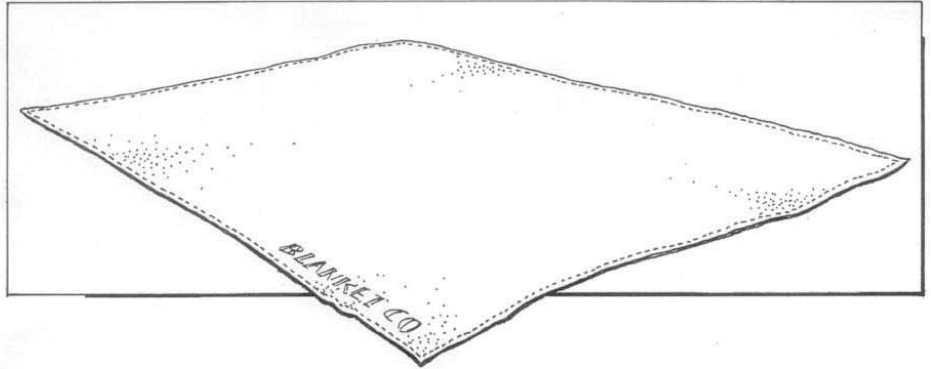



Household Information Form

Address: _____ Phone # : _____

Last name(s) of persons at this address: _____ Date _____

Work and School Information:

Adult name: _____ Work phone: _____

Employer's name: _____ Work hours: _____

Adult name: _____ Work phone: _____

Employer's name: _____ Work hours: _____

Children's names and schools:

Name: _____ Age: _____ School: _____

Name: _____ Age: _____ School: _____

Name: _____ Age: _____ School: _____

School(s) policy for release of children after disasters: _____

We have made arrangements for (name and phone #) _____

_____ to pick up our children if we are unable to do so.

Medical and Allergy Information:

Please list important medical information for your family. Include their name, medications they may need, allergies they may have, and any special needs they have.

In case of an emergency, please contact:

Name: _____ Relationship: _____ Phone: _____

Name: _____ Relationship: _____ Phone: _____

Pets:

Name: _____ Type: _____

Name: _____ Type: _____

In the event a member of my family is missing and presumed trapped in our home, I give permission for someone to enter my home to search for them.

In the event no one is home, I give permission for the water, gas, and/or electricity to be shut off if it is necessary for the safety of my home and neighborhood.

Signature: _____ Date: _____

This information will be kept strictly confidential, and will be used only during times of disaster.

Notes & Ideas

Fill out, cut apart and give to family members to keep with them.

Out-of-Area Contact Card

Name _____
Name of person at least 100 miles away

Contact Phone #'s _____

Fire Meeting Place _____
Near our home

Disaster Meeting Place _____
In case we cannot get home

Out-of-Area Contact Card

Name _____
Name of person at least 100 miles away

Contact Phone #'s _____

Fire Meeting Place _____
Near our home

Disaster Meeting Place _____
In case we cannot get home

Out-of-Area Contact Card

Name _____
Name of person at least 100 miles away

Contact Phone #'s _____

Fire Meeting Place _____
Near our home

Disaster Meeting Place _____
In case we cannot get home

Out-of-Area Contact Card

Name _____
Name of person at least 100 miles away

Contact Phone #'s _____

Fire Meeting Place _____
Near our home

Disaster Meeting Place _____
In case we cannot get home

Out-of-Area Contact Card

Name _____
Name of person at least 100 miles away

Contact Phone #'s _____

Fire Meeting Place _____
Near our home

Disaster Meeting Place _____
In case we cannot get home

Out-of-Area Contact Card

Name _____
Name of person at least 100 miles away

Contact Phone #'s _____

Fire Meeting Place _____
Near our home

Disaster Meeting Place _____
In case we cannot get home

Out-of-Area Contact Card

Name _____
Name of person at least 100 miles away

Contact Phone #'s _____

Fire Meeting Place _____
Near our home

Disaster Meeting Place _____
In case we cannot get home

Out-of-Area Contact Card

Name _____
Name of person at least 100 miles away

Contact Phone #'s _____

Fire Meeting Place _____
Near our home

Disaster Meeting Place _____
In case we cannot get home

Mercer Island Contact Numbers

Emergency	911
Non-Emergency	425-577-5656
Non-Emergency Fire	206-275-7607
Puget Sound Energy	1-888-225-5773
Radio Station	KIRO 710AM
	MIHS Radio 94.5 FM
Emergency Operations Center	206-275-7600
Shelter Site - Community Center	8236 SE 24 th St
Volunteer Meeting Place	Mercer Island City Hall
Emergency Manager	206-275-7905

Mercer Island Contact Numbers

Emergency	911
Non-Emergency	425-577-5656
Non-Emergency Fire	206-275-7607
Puget Sound Energy	1-888-225-5773
Radio Station	KIRO 710AM
	MIHS Radio 94.5 FM
Emergency Operations Center	206-275-7600
Shelter Site - Community Center	8236 SE 24 th St
Volunteer Meeting Place	Mercer Island City Hall
Emergency Manager	206-275-7905

Mercer Island Contact Numbers

Emergency	911
Non-Emergency	425-577-5656
Non-Emergency Fire	206-275-7607
Puget Sound Energy	1-888-225-5773
Radio Station	KIRO 710AM
	MIHS Radio 94.5 FM
Emergency Operations Center	206-275-7600
Shelter Site - Community Center	8236 SE 24 th St
Volunteer Meeting Place	Mercer Island City Hall
Emergency Manager	206-275-7905

Mercer Island Contact Numbers

Emergency	911
Non-Emergency	425-577-5656
Non-Emergency Fire	206-275-7607
Puget Sound Energy	1-888-225-5773
Radio Station	KIRO 710AM
	MIHS Radio 94.5 FM
Emergency Operations Center	206-275-7600
Shelter Site - Community Center	8236 SE 24 th St
Volunteer Meeting Place	Mercer Island City Hall
Emergency Manager	206-275-7905

Mercer Island Contact Numbers

Emergency	911
Non-Emergency	425-577-5656
Non-Emergency Fire	206-275-7607
Puget Sound Energy	1-888-225-5773
Radio Station	KIRO 710AM
	MIHS Radio 94.5 FM
Emergency Operations Center	206-275-7600
Shelter Site - Community Center	8236 SE 24 th St
Volunteer Meeting Place	Mercer Island City Hall
Emergency Manager	206-275-7905

Mercer Island Contact Numbers

Emergency	911
Non-Emergency	425-577-5656
Non-Emergency Fire	206-275-7607
Puget Sound Energy	1-888-225-5773
Radio Station	KIRO 710AM
	MIHS Radio 94.5 FM
Emergency Operations Center	206-275-7600
Shelter Site - Community Center	8236 SE 24 th St
Volunteer Meeting Place	Mercer Island City Hall
Emergency Manager	206-275-7905

Mercer Island Contact Numbers

Emergency	911
Non-Emergency	425-577-5656
Non-Emergency Fire	206-275-7607
Puget Sound Energy	1-888-225-5773
Radio Station	KIRO 710AM
	MIHS Radio 94.5 FM
Emergency Operations Center	206-275-7600
Shelter Site - Community Center	8236 SE 24 th St
Volunteer Meeting Place	Mercer Island City Hall
Emergency Manager	206-275-7905

Mercer Island Contact Numbers

Emergency	911
Non-Emergency	425-577-5656
Non-Emergency Fire	206-275-7607
Puget Sound Energy	1-888-225-5773
Radio Station	KIRO 710AM
	MIHS Radio 94.5 FM
Emergency Operations Center	206-275-7600
Shelter Site - Community Center	8236 SE 24 th St
Volunteer Meeting Place	Mercer Island City Hall
Emergency Manager	206-275-7905

OK

HELP