



BLUELINE

2022 Water System Improvements Project

Bid No. 22-02

Specifications and Contract Documents

Prepared for
City of Mercer Island
George Fletcher, CIP Project Manager
9611 SE 36th St
Mercer Island, WA 98040

THIS PAGE LEFT INTENTIONALLY BLANK

FOREWORD

THE ITEMS WHICH MAKE UP THE CONTRACT DOCUMENTS ARE AS FOLLOWS:

DIVISION 0

NOTICES, BIDDING REQUIREMENTS, AND AGREEMENT FORMS

Notices, Bidding Requirements, and Agreement Forms have been copied and bound together with the remainder of the Contract Documents to facilitate the bidder's submittal of this proposal and other required documents.

GENERAL TERMS AND CONDITIONS

SUPPLEMENTAL CONDITIONS

AMENDMENTS TO THE STANDARD SPECIFICATIONS - BY REFERENCE

TECHNICAL SPECIFICATIONS

APPENDICES

- A. Prevailing Minimum Hourly Wage Rates
- B. Sample K Plans
- C. Pothole Data
- D. Standard Details

PLANS (Bound Separately)

The Project Manual for the 2022 Water System Improvements Project for the City of Mercer Island has been prepared under the direction of the following Registered Professional Engineer.



3/11/2022

This Page Intentionally Left Blank

TABLE OF CONTENTS

DIVISION 0

NOTICES

I. Advertisement for Bids	N-1
II. Instructions to Bidders	N-3
III. Bidder's Checklist	N-11
IV. Bidder's Qualification Certificate	N-13
V. Contractor Declaration Pursuant to RCW 39.04.350(2)	N-15

BIDDING REQUIREMENTS

I. Noncollusion Declaration	A-3
II. Bid Form	A-5
III. Proposal Signature Sheet	A-11
IV. Bid Guaranty Bond	A-12

AGREEMENT FORMS

I. Public Works Contract	B-1
II. Performance Bond	B-11
III. Payment Bond	B-13
IV. Retainage Agreement	B-15

GENERAL TERMS AND CONDITIONS

SUPPLEMENTAL CONDITIONS

1-05	Control of Work	SC-1
1-10	Temporary Traffic Control	SC-2

TECHNICAL SPECIFICATIONS

DIVISION 2 – EARTHWORK

2-01	Clearing, Grubbing and Roadside Cleanup	TS-2
2-02	Removal of Structures and Obstructions	TS-3
2-03	Roadway Excavation and Embankment	TS-5
2-04	Haul	TS-5
2-06	Subgrade Preparation	TS-5
2-09	Structure Excavation	TS-6
2-11	Trimming and Cleanup	TS-6

DIVISION 3 – PRODUCTION FROM QUARRY AND PIT SITES AND STOCKPILING

3-01	Production from Quarry and Pit Sites	TS-7
------	--------------------------------------	------

DIVISION 4 – BASES

4-04	Ballast and Crushed Surfacing	TS-8
------	-------------------------------	------

DIVISION 5 – SURFACE TREATMENTS AND PAVEMENTS

5-04	Hot Mix Asphalt	TS-9
5-05	Cement Concrete Pavement	TS-10

DIVISION 7 – DRAINAGE STRUCTURES, STORM SEWERS, SANITARY SEWERS, WATER MAINS, AND CONDUITS

7-00	General Matters	TS-11
7-08	General Pipe Installation	TS-12
7-09	Water Mains	TS-13
7-12	Valves for Water Mains	TS-18
7-14	Hydrants	TS-19
7-15	Service Connections	TS-20

DIVISION 8 – MISCELLANEOUS CONSTRUCTION

8-01	Erosion Control and Water Pollution Control	TS-23
8-02	Roadside Restoration	TS-26
8-03	Irrigation Systems	TS-29
8-04	Curbs, Gutters, and Spillways	TS-29
8-13	Monuments	TS-29
8-14	Cement Concrete Sidewalk	TS-29

DIVISION 9 – MATERIALS

9-14	Erosion Control and Roadside Planting	TS-30
9-30	Water Distribution Materials	TS-31

DIVISION 10 – MEASUREMENT AND PAYMENT

Minor Change	TS-33
Record Drawings (Minimum Bid \$500.00)	TS-34
Mobilization (7% Maximum)	TS-34
Demobilization (3% Maximum)	TS-34
Shoring and Trench Safety Systems	TS-34
Flaggers and Spotters	TS-34
Other Temporary Traffic Control	TS-34
Potholing	TS-35
Crushed Surfacing Top Course	TS-35
Hot Mix Asphalt (HMA) Class B Temporary Trench Patch	TS-35
Hot Mix Asphalt (HMA) Class B Permanent Trench Patch	TS-35
Asphalt Cost Price Adjustment	TS-35
XX-inch D.I. Class 52 Water Main	TS-36
Joint Restraints – Locking Gaskets	TS-37
Additional D.I. Fittings	TS-37
XX-inch Gate Valve Assembly (Located Outside of Connections)	TS-38
Install New Fire Hydrant Assembly	TS-38
1-Inch Air Vacuum Release Assembly	TS-38

2-Inch Blowoff Assembly	TS-38
1-Inch Water Service, Short Side	TS-38
1-Inch Water Service, Long Side	TS-39
2-Inch Water Service for 1 1/2-Inch Meter, Short Side	TS-39
2-Inch Water Service for 1 1/2-Inch Meter, Long Side	TS-39
Intercept Existing Water Service	TS-40
Customer Side Reconnection Over 5 Feet	TS-40
Connection X to Existing System	TS-40
Wet Tap Connection X to Existing Water System	TS-40
Abandon Existing Water System	TS-40
Controlled Density Fill (CDF) (As Necessary)	TS-41
Adjust Monument to Grade	TS-41
Cement Concrete Sidewalk	TS-41
Cement Concrete Curb and Gutter	TS-41
Additional Temporary Erosion and Sedimentation Control (TESC)	TS-41
Catch Basin Insert	TS-41
Property and Landscape Restoration	TS-42
Temporary Pavement Markings	TS-42
Plastic Stop Line	TS-42
Plastic Crosswalk Line	TS-42
Paint Line	TS-42
Traffic Letter/Number	TS-42
Raised Pavement Marker Type XX	TS-42
Precast Dual Faced Sloped Mountable Curb	TS-42

APPENDIX

- A. Prevailing Minimum Hourly Wage Rates
- B. Sample K Plans
- C. Pothole Data
- D. Standard Details

PLANS (Bound Separately)

This Page Intentionally Left Blank

NOTICES

This Page Intentionally Left Blank

Advertisement for Bids City of Mercer Island

Project Title: 2022 Water System Improvements Project
Bid Number: 22-02
Engineers Estimated Cost (range): \$1,800,000 - \$2,000,000

Sealed bids will be received, not sent, electronically by the City until 2 pm on March 30, 2022. Due to the COVID-19 pandemic and the temporary closure of the City Hall building, bidders shall submit their bids in PDF format to the Public Works email address at publicworks@mercerisland.gov. There will be no public bid opening for this project; bid results will be posted on the City's webpage at: <https://www.mercerisland.gov/rfps>.

IMPORTANT NOTES:

- 1) There will be no public bid opening for this project. Bid results will be posted on City's web page at: <http://www.mercergov.org/RFPs>.
- 2) Due to the restrictions imposed by State government in response to the global pandemic of Coronavirus, the start date and construction schedule may be affected. Bidders are advised to include this consideration when submitting their bids.

Work to be performed under this contract includes, but is not limited to:

Work generally consists of constructing 85 LF of new 4-inch DI water main, 4,345 LF of new 8-inch DI water main, 20 LF of new 12-inch DI water main, 10 fire hydrants, 112 water services, 6 connections to existing water main, permanent hot mix asphalt patching, concrete sidewalk repairs, and concrete curb and gutter repairs. Temporary erosion/water pollution control, temporary traffic control and devices, property restoration and other miscellaneous items will also be necessary to complete the work.

A single contract is to be awarded to the responsible bidder submitting the lowest responsive bid. The City reserves the right to reject any and all bids and to waive minor irregularities.

Plans, specifications, addenda, and bidders list are available on-line through Builders Exchange of Washington, Inc. at <http://www.bxwa.com>. Click on "Posted Projects", "Public Works", "City of Mercer Island", "Projects Bidding". Builders Exchange manages the official bidders list. Bidders are encouraged to register in order to receive automatic email notification of future addenda and to be placed on the official bidders list.

Plans and specifications are also available at the City of Mercer Island website <http://www.mercergov.org/RFPS>. Addenda may not be available or updated on this website.

A bid deposit in the amount of five percent (5%) of the bid total price must accompany each bid.

Bidder questions are to be directed to George Fletcher, CIP Project Manager, by email at George.fletcher@mercerisland.gov, or by phone at 206-640-5379.

Andrea Larson, City Clerk

Published: Seattle Daily Journal of Commerce 3/16/2022 and 3/23/2022

This Page Intentionally Left Blank

City of Mercer Island Instructions to Bidders

1. ELIGIBILITY TO BID:

It is the intent of the City to award a contract to the low responsible bidder. Before award, the bidder must meet the following bidder responsibility criteria to be considered a responsible bidder. To be eligible to bid, each Bidder must:

- A. At the time of bid submittal, have a current certificate of registration as a contractor in compliance with chapter 18.27 RCW; and
- B. Have a current Washington Unified Business Identifier (UBI) number; and
- C. If applicable:
 - i. Have Industrial Insurance (workers' compensation) coverage for the bidder's employees working in Washington, as required in Title 51 RCW; and
 - ii. Have a Washington Employment Security Department number, as required in Title 50 RCW; and
 - iii. Have a Washington Department of Revenue state excise tax registration number, as required in Title 82 RCW; and
- D. Not be disqualified from bidding on any public works contract under RCW 39.06.010 or 39.12.065(3); and
- E. Within the three-year period immediately preceding the date of the bid solicitation, not have been determined by a final and binding citation and notice of assessment issued by the department of labor and industries or through a civil judgment entered by a court of limited or general jurisdiction to have willfully violated, as defined in RCW 49.48.082, any provision of chapter 49.46, 49.48 or 49.52 RCW.

A contract shall only be awarded to a Bidder that demonstrates to the City's satisfaction that the Bidder is qualified to perform the Work and is, therefore, a responsible bidder.

2. SUBCONTRACTOR RESPONSIBILITY CRITERIA:

The Bidder must verify responsibility criteria for each first-tier subcontractor, and each subcontractor of any tier that hires other subcontractors must verify responsibility criteria for each of its subcontractors. Upon request of the City the Bidder shall promptly provide documentation to the City demonstrating that the subcontractor(s) meets the subcontractor responsibility criteria below. The requirements of this section apply to all subcontractors regardless of tier.

At the time of subcontract execution, the Bidder shall verify that each of its first-tier subcontractors meets the following bidder responsibility criteria:

- A. Have a current certificate of registration in compliance with chapter 18.27 RCW; and
- B. Have a current Washington Unified Business Identifier (UBI) number; and

- C. If applicable:
 - i. Have Industrial Insurance (workers' compensation) coverage for the subcontractor's employees working in Washington, as required in Title 51 RCW; and
 - ii. Have a Washington Employment Security Department number, as required in Title 50 RCW; and
 - iii. Have a Washington Department of Revenue state excise tax registration number as required in Title 82 RCW; and
 - iv. Have an electrical contractor license, if required by Chapter 19.28 RCW; and
 - v. Have an elevator contractor license, if required by Chapter 70.87 RCW; and
- D. Not be disqualified from bidding on any public works contract under RCW 39.06.010 or 39.12.065 (3); and

3. EXAMINATION OF PLANS, SPECIFICATIONS AND SITE:

Each bidder is instructed to examine the Plans, Specifications, Addenda, the site of the proposed improvements, and conduct any other examination and investigation which the bidder may desire to make as to the accuracy of the nature of the work and the difficulties to be encountered. The Bidder shall be responsible for all costs associated with these additional examinations including all restoration work and damages which may be a result of such investigation. Bidders shall consider Federal, State, and local laws and regulations that may affect cost, progress, or performance of the work.

4. ADDITIONAL INFORMATION:

All questions about the meaning or intent of the Contract Documents are to be directed to George Fletcher, in writing by email at george.fletcher@mercergov.org.

Interpretations or clarifications considered necessary by the City in response to such questions will be issued by Addenda mailed or delivered to all parties recorded by the Engineer or City as having received the Contract Documents. Questions received less than ten (10) days prior to the date for opening of Bids may not be answered. Only questions answered by formal written Addenda will be binding. Oral and other interpretations or clarifications will be without legal effect.

5. WAGES:

This Contract is subject to Chapters 39.12 and 49.28 RCW, amendments thereto and regulations issued thereunder, relating to prevailing wages, benefits and other requirements. Bidders shall examine and be familiar with such requirements. No claim for additional compensation will be allowed which is based upon a lack of knowledge or a misunderstanding of any such requirements by the Bidder or a failure to include in Bidder's price adequate increases in such wages during the performance of this Contract. A copy of the most recent prevailing wage schedule is in the Appendix of the specifications. Current prevailing wage rates for King County can be obtained from the Washington State Department of Labor and Industries at www.lni.wa.gov/TradesLicensing/PrevWage/.

6. PROGRESS AND COMPLETION:

Time is of the essence for this Project. Progress and completion of the Work shall comply with all requirements herein, and intermediate and final completion dates as may be set forth in the specifications. The submission of

a bid constitutes the Bidder's acknowledgement that such progress and completion requirements have been taken into account in formulating a price for this Work.

7. PREVENTION OF ENVIRONMENTAL POLLUTION AND PRESERVATION OF PUBLIC NATURAL RESOURCES:

If awarded the Contract, the Bidder shall fully comply with all such environmental protection laws, ordinances and regulations dealing with prevention and environmental pollution and the preservation of public natural resources that may be applicable to this Project. The cost of such compliance shall be included in the bid prices.

8. BID FORM:

The Bid Form is included in the Contract Documents. The Bid Form must be completed in ink. Bids that contain omissions, erasures or irregularities of any kind may be rejected. Any qualification, addition, limitation or provision attached to or contained in a bid may render the bid non-responsive and not eligible for award. No oral, facsimile, telegraphic or telephonic bids or modifications will be considered.

All bids shall be signed by the Bidder, or the Bidder's authorized representative. If the bid is made:

- A. By an individual, the Bidder's name, signature, and address must be shown;
- B. By a partnership or joint venture, it shall contain the names of each partner, the mailing address of the partnership or joint venture and shall be signed in the firm name, followed by the signature of the person signing, indicating that person's position in the partnership or joint venture;
- C. By a corporation or limited liability company ("LLC"), the name of the state under the laws of which the corporation or LLC is chartered, the name and post office address of the corporation or LLC and the title of the person who signs on behalf of the corporation or LLC must be shown.

Upon the City's request, the Bidder shall provide copies of the articles of incorporation, bylaws, resolutions of board of directors, partnership papers, joint venture agreements, and any other documents evidencing the legal status of the Bidder and the authority of the Bidder's officer or representative who signed the bid on behalf of the Bidder.

The City is not responsible for any cost incurred in responding to this Call for Bids.

9. ACKNOWLEDGEMENT OF ADDENDA:

Each Bidder shall include on the Bid Form specific acknowledgment of receipt of each Addendum issued by the City during the bidding period. If the Bidder does not specifically acknowledge each addendum, the City may reject the bid as non-responsive unless the City determines from delivery records or from inclusion of information in the bid of information contained in the addenda that the Bidder received constructive notice of the addenda.

10. BID SECURITY:

The Bid shall be accompanied by a bid deposit in the amount equal to at least 5% of the Total Bid Price. The bid deposit shall be in one of the following formats and made payable to the City:

- A. A bid guaranty bond, in accordance with and using a form acceptable to the City which contains provisions substantially similar to those in the bid bond form included with the Contract Documents, duly completed by a guaranty company authorized to carry on business in the state of Washington; or
- B. A postal money order, a certified check, or cashier's check drawn upon a banking institution with a branch office in the state of Washington.

The surety signing the bid guaranty bond shall be registered with the Washington State Insurance Commissioner, and the surety's name shall appear in the current Authorized Insurance Company List in the State of Washington published by the Office of the Insurance Commissioner. A Power of Attorney must accompany the bid guaranty bond and must appoint the surety's true and lawful attorney-in-fact to make, execute, seal and deliver the bid guarantee bond. Failure to submit the required bid security with the Bid shall render the bid non-responsive and the Bid shall be rejected.

11. NON-COLLUSION:

Each bid shall be accompanied by a signed Non-Collusion Declaration in accordance with, and using the form provided by the City. Failure to submit a signed Declaration with the Bid shall render the bid non-responsive and the Bid shall be rejected.

More than one Bid from an individual, firm, partnership, corporation, or association under the same or different names will not be considered. If the City believes that any Bidder is interested in more than one Bid for the work contemplated, all Bids in which such Bidder is interested will be rejected. If the City believes that collusion exists among the Bidders, all Bids will be rejected.

12. DELIVERY OF BID:

Each Bid shall be submitted in a PDF format via electronic transmission to Public Works email address at: publicworks@mercergov.org. The City will not consider bids received after the time fixed for opening bids in the Advertisement for Bids.

The submission of a Bid will constitute an incontrovertible representation by the Bidder that the Bidder has complied with every requirement of these instructions, that without exception the Bid is premised upon performing the work required by the Contract Documents and such means, methods, techniques, sequences, or procedures of construction as may be indicated in or required by the Contract Documents, and that the Contract Documents are sufficient in scope and detail to indicate and convey understanding of all terms and conditions for performance of the work.

13. MODIFICATION OF BID:

A modification of a Bid will be considered only if the modification is received prior to the time announced for the opening of Bids. All modifications shall be made in writing executed and submitted in the same form and manner as the original Bid.

14. RETURN OF BID SECURITY:

After the bid prices have been compared, the City may return the bid security if, in the City's judgment, the Bidder would not be considered for award. All other Proposal Guarantees will be held until the Contract and the Performance Bond of the successful bidder have been executed.

15. EVALUATION OF BIDS AND BID ERRORS:

After opening the Bids, the City will check them for correctness of extensions of the prices per unit and the total price. If a discrepancy exists between the price per unit and the extended amount of any bid item, the price per unit will control. The total of extensions, corrected where necessary, will be used by the City for award purposes.

Irregular Bids:

- A. A Bid will be considered irregular and will be rejected if:
 - i. The authorized Bid Form furnished by the City is not used or is materially altered;
 - ii. The completed Bid Form contains any unauthorized additions, deletions, alternate bids, or conditions;
 - iii. The bidder adds provisions reserving the right to reject or accept the Award, or enter into the Contract;
 - iv. A price per unit cannot be determined from the Bid Form;
 - v. The Bid Form is not properly executed;
 - vi. An executed non-collusion certificate is not provided; or
 - vii. Proper bid security does not accompany the Bid.

- B. A Bid may be considered irregular and may be rejected if:
 - i. The Bid Form does not include a unit price for every Bid item;
 - ii. Any of the unit prices are excessively unbalanced (either above or below the amount of a reasonable Bid) to the potential detriment of the City;
 - iii. Receipt of Addenda is not acknowledged;
 - iv. A member of a joint venture or partnership and the joint venture or partnership submit Bid Forms for the same project (in such an instance, both Bids may be rejected); or
 - v. If Bid Form entries are not made in ink.

Bids will be evaluated by the City to determine which bid is the apparent lowest, responsive bid.

Bid results will be posted on the City's website at www.mercergov.org.

The City, in its sole discretion, reserves the right to waive minor bid errors, informalities, and immaterial irregularities when it is in the City's best interest to do so.

16. EVALUATION OF BIDDER RESPONSIBILITY:

A Contract shall only be awarded to a Bidder that demonstrates to the City's satisfaction that the Bidder is qualified to perform the Work and is, therefore, a responsible bidder.

- A. Bidder Responsibility Criteria. To be determined responsible, the Bidder must, in addition to satisfying the bidder responsibility criteria listed in Section 1. ELIGIBILITY TO BID above:
 - i. Have adequate financial resources to perform the contract, or the ability to obtain them;
 - ii. Have a satisfactory performance record;

- iii. Have a satisfactory record of integrity and business ethics;
 - iv. Have the necessary production, construction, and technical equipment and facilities or the ability to obtain them;
 - v. Be otherwise qualified and eligible to receive an award under applicable laws and regulations;
 - vi. Be in compliance with training requirements in RCW 39.04.350(1)(f); and
 - vii. Provide a statement in accordance with RCW 9A.72.085 verifying compliance with responsible bidder criteria requirement of RCW 39.04.350(1)(g).
- B. Reference Checking. To assist the City in the review of the Bidder's qualifications, the Bidder shall, within five (5) days of being requested to do so by the City, provide the following information:
- i. Past Experience in Similar Projects. Provide a list of all construction contracts (whether completed or in progress) entered into or performed by the Bidder within the past five (5) years for projects similar in scope, time and complexity to the work called for under this Contract. Provide the names of the contracts, the contract price, and the names and phone numbers of the owners.
 - ii. References. Provide a list of five (5) references. References will be asked to rate performance on the following items: overall project performance; acceptable experience and technical knowledge; effective coordination of subcontractors; ability to coordinate and work with utility companies and governmental entities; responsiveness to owner requests; attention to safety; quality and timeliness of submittals, change order proposals, project schedule, schedule updates and other applicable paperwork.

If the Bidder is a joint venture, the Bidder shall submit information for the joint venture if the members have worked together in the past and also information about each member of the joint venture. The Joint Venture Agreement shall be included in the submission.

If the Bidder fails to supply information requested concerning responsibility within the time and the manner specified, the City may base its determination of responsibility upon any available information related to the responsibility criteria or may find the Bidder is not responsible.

The City reserves the right to inspect records, reports and other information which may be maintained by or for the Bidder to the extent necessary, as determined by the City to verify, clarify or otherwise consider the information provided by the Bidder.

17. DETERMINATION OF NON-RESPONSIBILITY:

If the City determines a Bidder to be not responsible, the City will provide, in writing, the reasons for the determination. The Bidder may appeal the determination within ten (10) days of its receipt of the City's determination of non-responsibility by presenting additional information to the City. The City shall consider the additional information before issuing its final determination. If the City's final determination affirms that the Bidder is not responsible, the City shall not execute a contract with any other bidder until two (2) business days after the Bidder determined to be not responsible has received the final determination.

18. CONTRACT AWARD:

If a Contract is awarded, the City will award the contract to the responsible bidder that submits the lowest total responsive bid for the schedule(s) selected by City after bid opening and prior to award.

If the Contract is to be awarded, City will give the successful Bidder a Notice of Award within sixty (60) days after the day of the Bid opening. No other act of the City or others will constitute acceptance of a Bid.

The City reserves the right to request bidders to extend the effective period of their bids.

19. REJECTION OF ALL BIDS:

The City reserves the right to reject any or all Bids at any time up to actual execution of the Public Works Contract, even if there has been an award of the Contract.

Any or all Bids will be rejected if the City has reason to believe that collusion exists among the Bidders.

20. EXECUTION OF PUBLIC WORKS CONTRACT:

The Bidder to whom award is made shall execute a written Public Works Contract with the City on the form provided, shall secure all insurance, and shall furnish all certificates, endorsements and bonds required by the Contract Documents within ten (10) calendar days after receipt of the forms from the City. Failure or refusal to execute the Public Works Contract as herein provided or to conform to any of the stipulated requirements in connection therewith shall be just cause for annulment of the award and forfeiture of the Bid security. If the lowest responsive, responsible Bidder refuses or fails to execute the Public Works Contract, the City may award the Contract to the second lowest responsive, responsible Bidder. If the second lowest responsive, responsible Bidder refuses or fails to execute the Public Works Contract, the City may award the contract to the third lowest responsive, responsible Bidder. On the failure or refusal of such second or third lowest Bidder to execute the Agreement, each such Bidder's Bid securities shall be likewise forfeited to the City.

21. BID PROTEST PROCEDURES:

- A. Form of Protest. In order to be considered, a Protest shall be in writing, addressed and delivered to the attention of the project manager at the City of Mercer Island, 9611 SE 36th Street, Mercer Island, Washington 98040. The Protest shall include the following:
 - i. The name, address, and phone number of the Bidder protesting, or the authorized representative of the Bidder;
 - ii. A complete, detailed statement of all grounds for protest, supporting authority, and any supporting documentation. Supplemental information will not be considered unless the supplementation contains information not available at the time of protest;
 - iii. The specific ruling or relief requested; and
 - iv. Evidence that all persons with a financial interest in the procurement have been given notice of the Protest or if such persons are unknown, a statement to that effect.

- B. Who May Protest:
 - i. Protests based on specifications: Any prospective Bidder.

- ii. Protests following Bid opening: Any Bidder with a substantial financial interest in the award of a Contract.
- C. Time to Protest:
- i. Protests based on specifications or other terms in the Contract Documents must be received by the City no later than ten (10) calendar days prior to the date established for submittal of Bids.
 - ii. The City must receive protests based on other circumstances within five (5) calendar days after the bids are opened and publicly read.
 - iii. In no event shall a Protest be considered if all bids are rejected or after execution of the Contract.
- D. Determination of Protest. Upon receipt of a timely written Protest, the City shall investigate the Protest and shall respond in writing to the Protest prior to the award of Contract. If protest is submitted in accordance with the procedures set forth above, the City will not execute a contract any sooner than two (2) business days after the City's decision on the Protest.
- E. Failure to Comply. Failure to comply with the procedures set forth herein may render a Protest untimely or inadequate and may result in rejection thereof by the City.
- F. Exhaustion of Administrative Remedies. By submitting a bid, the Bidder agrees the Bidder's compliance with the protest procedures set forth herein are a mandatory condition precedent to the Bidder initiating a lawsuit against the City.
- G. Venue. By submitting a bid, the Bidder acknowledges and agrees that a lawsuit or action related to or arising out of this procurement shall be brought in the Superior Court of King County, Washington.

Bidder's Checklist

ALL BIDDERS must properly complete, execute and submit the following with their bids:

1. **NON-COLLUSION DECLARATION:** Failure to submit the certificate shall make the bid non-responsive and not eligible for award.
2. **BID FORM:** Bidders must bid on all items contained in the Bid Form and the Form must be signed. The omission or deletion of any bid item may render the bid non-responsive and result in the rejection of the bid. Bidders are reminded to comply with RCW 39.30.060.
3. **CONTRACTOR DECLARATION PURSUANT TO RCW 39.04.350(2):** Failure to submit the declaration shall make the bid non-responsive and not eligible for award.
4. **BID GUARANTY BOND:** Failure to furnish a bid deposit of a minimum of five percent (5%) shall make the bid non-responsive and not eligible for award.
5. **BIDDERS QUALIFICATION CERTIFICATE:** To be completed and signed. The City reserves the right to check all statements and to judge the adequacy of the bidder's qualifications.

To assist the City in the review of the responsible Bidder's qualifications, the Bidder(s) shall, within five (5) days of being requested to do so by the City, provide the information required in Evaluation of Bidder Responsibility of the Instructions to Bidders, including a statement in accordance with RCW 9A.72.085 verifying compliance with responsible bidder criteria requirement of RCW 39.04.350(1)(g).

The **SUCCESSFUL BIDDER** shall properly complete, execute (as required) and submit the following after receiving notice of the award of the Project.

1. Public Works Contract,
2. Performance Bond,
3. Payment Bond,
4. Certificate of Insurance,
5. Retainage Agreement,
6. Statement of Intent to Pay Prevailing Wages,
7. Other documents requested by City.

This Page Intentionally Left Blank

Bidder's Qualification Certificate

The undersigned hereby certifies and submits the following:

Company Name _____
Address _____

Owner Name _____
Contact Person _____
Contact Person's Title _____
Phone _____
E-mail _____

Washington State Contractor Registration # _____
Washington State Unified Business Identifier (UBI) # _____
Federal Tax ID # _____
City of Mercer Island Business License #
(required prior to award of contract) _____

	Yes or No	Account / Registration Number (as applicable)
Does the contractor have industrial insurance coverage for its employees working in Washington as required by Title 51 RCW?	_____	_____
Does the contractor have a Washington State excise tax registration number as required by Title 82 RCW?	_____	_____
Does the contractor have a Washington State Employment Security Department number as required by Title 50 RCW?	_____	_____
Has the contractor been disqualified from bidding on any public works contract under RCW 39.06.010 or 39.12.065(3)?	_____	_____
Has the contractor received training on the requirements related to public works contracts and prevailing wage requirements pursuant to RCW 39.04.350(f) and chapter 39.12 RCW, or is the contractor otherwise exempt from this requirement by the department of labor and industries?	_____	_____
Within the three-year period immediately preceding the date of the bid solicitation, has the contractor been determined by a final and binding citation and notice of assessment issued by the Department of Labor and Industries or through a civil judgment entered by a court of limited or general jurisdiction to have willfully violated, as defined in RCW 49.48.082, any provision of Chapters 49.46, 49.48, or 49.52 RCW?	_____	_____

By: _____
Signature
Title

Print Name
Date

This Page Intentionally Left Blank

Contractor Declaration Pursuant to RCW 39.04.350(2)

Project Name: 2022 WATER SYSTEM IMPROVEMENTS PROJECT

Bidder/Contractor:

I, _____, declare under penalty of perjury under the laws of the State of Washington that the foregoing is true and correct:

1. I am the representative for the above-named bidder/contractor, and as its _____, I am authorized to make the declaration herein on its behalf.

2. Within the three-year period immediately preceding the date of the bid solicitation for the above-named project, the above-named bidder/contractor has not been determined by a final and binding citation and notice of assessment issued by the department of labor and industries or through a civil judgment entered by a court of limited or general jurisdiction to have willfully violated, as defined in RCW 49.48.082, any provision of chapter 49.46, 49.48, or 49.52 RCW.

Date and Place

Signature

This Page Intentionally Left Blank

BIDDING REQUIREMENTS

This Page Intentionally Left Blank

NON-COLLUSION DECLARATION

Project Name: 2022 Water System Improvements Project

Bidder/Contractor: _____

I, _____, declare under penalty of perjury under the laws of the State of Washington that the following statements are true and correct:

1. I am the representative for the above-named bidder/contractor, and as its _____, I am authorized to make the declaration herein on its behalf.
2. That the undersigned person(s), firm, association or corporation has (have) not, either directly or indirectly, entered into any agreement, participated in any collusion, or otherwise taken any action in restraint of free competitive bidding in connection with the project for which this proposal is submitted.

Date and Place

Signature

This Page Intentionally Left Blank

BID FORM

(NOTE TO BIDDER: This BID FORM shall be completed in ink or typewritten)

TO: City of Mercer Island
ADDRESS: 9611 SE 36th Street
Mercer Island, Washington 98040
PROJECT TITLE: 2022 Water System Improvements Project

Bidder Declaration and Understanding

The undersigned Bidder hereby declares that they have carefully examined the Contract Documents for the construction of the project, that they have personally inspected the site, that they have satisfied themselves as to the quantities involved, including materials and equipment, and conditions of work involved, including the fact that the description of the quantities of work and materials, as included herein, is brief and is intended only to indicate the general nature of the work and to identify the quantities with the detailed requirements of the Contract Documents, and that this Proposal is made according to the provisions and under the terms of the Contract Documents, which Documents are hereby made a part of this Proposal. The Bidder further declares that they have exercised their own judgment regarding the interpretation of subsurface information and has utilized all data, which they believe pertinent from the Engineer, Owner, and other sources and have made such independent investigations as the Bidder deems necessary in arriving at their conclusions.

The Bidder is hereby notified that no goal for disadvantaged business enterprise utilization has been established for this project. As part of the City's affirmative action effort, however, the City encourages participation of certified disadvantaged businesses and women business enterprises to act as prime contractors as well as subcontractors on this project.

The undersigned Bidder hereby declares that Bidder has carefully examined the Contract Documents including the following addenda, receipt of all is hereby acknowledged:

Addendum Number _____ Date _____

Start of Construction and Contract Completion Time

The Bidder agrees that he will begin work within 10 calendar days of the Notice to Proceed, and Final Completion of the entire project will be achieved by the Final Completion Date (except for extensions of time granted in accordance with the General Terms and Conditions). The Bidder further agrees he/she will, if necessary, accelerate his work, provide additional workers and equipment, and expedite materials delivery to meet these dates, all at no additional expense to the OWNER.

By submitting this bid, the bidder agrees that, if awarded this contract, they will achieve Final Completion within 140 working days from the Notice to Proceed and the Substantial Completion Date shall be 130 working days from Notice to Proceed.

Project Timeline and Work Limitations

1. A contract is scheduled for City Council award on April 19, 2022.
2. A preconstruction meeting is tentatively planned for the week of April 25, 2022.
3. Notice to Proceed with construction is anticipated the week of May 2, 2022.
4. Start of construction is anticipated no earlier than May 2, 2022.
5. The last day of the 2021-2022 school year is June 22, 2022.
6. Due to the proximity of schools to the project area and the amount of school-related vehicle and pedestrian traffic on SE 40th Street, no pipe laying or water service replacement activities shall occur on SE 40th Street or its intersections until after June 22.
7. No major construction work shall occur on SE 40th Street from August 3, 2022 thru August 5, 2022. Seafair airshow practices will close the I-90 floating bridge several times on these days, which greatly increases the mid-day traffic volume through the SE 40th Street corridor to and from Gallagher Hill Road.
8. The first day of the 2022-2023 school year is August 31, 2022.
9. All curb, gutter, and sidewalk repairs and permanent asphalt patching on SE 40th Street and its intersections shall be completed by August 26, 2022.

Lump Sum or Unit Price Work

The Bidder proposes to accept as full payment for the work proposed herein the amounts computed under the provisions of the Contract Documents and based on the following lump sum or unit price amounts, it being expressly understood that the unit prices are independent of the exact quantities involved. The Contractor shall be compensated for the actual unit quantities performed in accordance with the General Terms and Conditions set forth in these Contract Documents. The Bidder agrees that the lump sum prices and the unit prices represent a true measure of the labor, services, and materials required to perform the work, including all allowances for Contractor-paid taxes, overhead, and profit for each type and unit of work, as well as any auxiliary costs associated with completing a unit of work called for in these Contract Documents. The City does not guarantee the quantities estimated for unit price items, nor does the City limit itself to the estimated number.

If any material, item, or service required by the Contract Documents has not been mentioned specifically, the same shall be furnished and placed with the understanding that the full cost to the Owner has been merged with the prices named in the Proposal.

To the extent possible, standard bid items have been utilized for the work listed in the Proposal. The Bidder is directed to review the Standard Specifications and the City of Mercer Island's Amendments (Technical Specifications herein) for descriptions of bid item work, measurement, and payment.

Certification of Non-Segregated Facilities

The Bidder certifies that the Bidder does not maintain or provide for the Bidder's Employees any segregated facilities at any of the Bidder's establishments, and that the Bidder does not permit the Bidder's employees to perform their services at any location, under the Bidder's control, where segregated facilities are maintained.

Prevailing Wages

The Bidder agrees to pay to labor not less than the hourly minimum rates of wages and fringe benefits determined by the State of Washington Department of Labor and Industries as included in the Appendix.

Bid Schedule

NO	DESCRIPTION OF ITEM	QTY	UNITS	UNIT PRICE	AMOUNT
1	Minor Change	1	FA	\$50,000.00	\$50,000.00
2	Record Drawings (Minimum Bid \$500.00)	1	LS		
3	Mobilization (7% Maximum)	1	LS		
4	Demobilization (3% Maximum)	1	LS		
5	Shoring and Trench Safety Systems	1	LS		
6	Flaggers and Spotters	2,465	HR		
7	Other Temporary Traffic Control	1	LS		
8	Potholing	38	EA		
9	Crushed Surfacing Top Course	5,600	TN		
10	Hot Mix Asphalt (HMA) Class B Temporary Trench Patch	240	TN		
11	Hot Mix Asphalt (HMA) Class B Permanent Trench Patch	750	TN		
12	Asphalt Cost Price Adjustment	1	CALC	\$1,122.00	\$1,122.00
13	4-inch D.I. Class 52 Water Main	85	LF		
14	8-inch D.I. Class 52 Water Main	4,345	LF		
15	12-inch D.I. Class 52 Water Main	20	LF		
16	Joint Restraints - Locking Gaskets	10	EA		
17	Additional D.I. Fittings	4,350	LB		
18	4-inch Gate Valve Assembly (Located Outside of Connections)	1	EA		
19	8-inch Gate Valve Assembly (Located Outside of Connections)	22	EA		
20	Install New Fire Hydrant Assembly	10	EA		

21	1-Inch Air Vacuum Release Assembly	3	EA		
22	2-Inch Blowoff Assembly	1	EA		
23	1-Inch Water Service, Short Side	46	EA		
24	1-Inch Water Service, Long Side	50	EA		
25	2-Inch Water Service for 1 1/2-inch Meter, Short Side	7	EA		
26	2-Inch Water Service for 1 1/2-inch Meter, Long Side	9	EA		
27	Intercept Existing Water Service	1	EA		
28	Customer Side Reconnection Over 5 Feet	1	FA	\$20,000.00	\$20,000.00
29	Connection A to Existing Water System	1	LS		
30	Connection B to Existing Water System	1	LS		
31	Connection C to Existing Water System	1	LS		
32	Connection D to Existing Water System	1	LS		
33	Wet Tap Connection E to Existing Water System	1	LS		
34	Connection F to Existing Water System	1	LS		
35	Abandon Existing Water System	1	LS		
36	Controlled Density Fill (CDF) (As Necessary)	10	CY		
37	Adjust Monument to Grade	4	EA		
38	Cement Concrete Sidewalk	30	SY		
39	Cement Concrete Curb and Gutter	60	LF		
40	Additional Temporary Erosion and Sedimentation Control (TESC)	1	FA	\$5,000.00	\$5,000.00
41	Catch Basin Insert	102	EA		

42	Property and Landscape Restoration	1	FA	\$20,000.00	\$20,000.00
43	Temporary Pavement Markings	1	FA	\$1,000.00	\$1,000.00
44	Plastic Stop Line	15	LF		
45	Plastic Crosswalk Line	80	SF		
46	Paint Line	90	LF		
47	Traffic Letter/Number	10	EA		
48	Raised Pavement Marker 1Y	0.30	HUND		
49	Raised Pavement Marker 2YY	0.05	HUND		
50	Precast Dual Faced Sloped Mountable Curb	10	LF		

Subtotal _____

Sales Tax (10.1%) _____

Total _____

Subcontractor Listing – RCW 39.30.060

Pursuant to RCW 39.30.060, the Bidder shall list as part of its Bid either itself or the names of the subcontractors with whom the Bidder, if awarded the contract, will subcontract for performance of the work of heating, ventilation and air conditioning (“HVAC”), plumbing as described in chapter 18.106 RCW, and electrical as described in chapter 19.28 RCW. The Bidder shall not list more than one subcontractor for each category of work.

Failure of the Bidder to submit as part of the Bid the names of such subcontractors or to name itself to perform such work or the naming of two or more subcontractors to perform the same category of work shall render the Bidder’s Bid nonresponsive and therefore, void.

The requirement of this section to name the Bidder’s proposed HVAC, plumbing, and electrical subcontractors applies only to proposed HVAC, plumbing, and electrical subcontractors who will contract directly with the general contractor submitting the Bid to the City.

Electrical work must be performed by a licensed electrical contractor. Bidders are cautioned that installation of electrical equipment (PVC or metal conduit, junction boxes or similar work) may be considered electrical work even if for future use and no electrical current is involved.

If the subcontract work categories as described above are not applicable to the work being bid, the bidder must indicate that the subcontract category is “NOT APPLICABLE.”

HVAC

Subcontractor Name: _____

UBI Number: _____

Plumbing

Subcontractor Name: _____

UBI Number: _____

Electrical

Subcontractor Name: _____

UBI Number: _____

PROPOSAL SIGNATURE SHEET

If Sole Proprietor, Partnership or Joint Venture

IN WITNESS hereto the undersigned have set their hands this

_____ day of _____, 20 _____.

Name of Bidder (name each partner
or joint venture partner)

Washington Contractor's Registration
No.

Address

Authorized Signature

Position/Title

If Corporation or Limited Liability Company (LLC)

IN WITNESS WHEREOF the undersigned corporation has caused this instrument to be executed and its seal
affixed by its duly authorized officers this

_____ day of _____, 20 _____.

Name of Corporation or Limited
Liability Company (LLC)

Washington Contractor's Registration
No.

Address

State of Incorporation or Organization

Authorized Signature

Position/Title

BID GUARANTY BOND

KNOW ALL BY THESE PRESENTS: That we, _____,
as Principal, and _____, as Surety, are jointly and severally held and firmly
bound unto the City of Mercer Island, hereinafter called the Obligee, each in the penal sum of five percent (5%) of the
Principal's Total Bid Price for the work, this sum not to exceed _____ DOLLARS
(\$_____) (hereinafter referred to as "penal sum") of lawful money of the United States, for the payment whereof
unto the Obligee.

WHEREAS, the Principal is herewith submitting its bid proposal for the

2022 Water System Improvements Project

NOW, THEREFORE, the condition of this obligation is such that if the Principal is awarded the Contract, and if the
Principal, within the time specified, fulfills all of the requirements of the Contract Documents which are conditions
precedent to the execution of the Agreement, enters into, executes and delivers to the Obligee an agreement on the
form provided herein complete with evidences of insurance, and if the Principal, within the time specified, gives to the
Obligee the performance and payment bond on the forms provided herein, then this obligation shall be void;
otherwise, the Principal and Surety shall pay unto the Obligee the penal sum; provided however, in no event shall the
Surety's liability exceed the penal sum. Provided further, if the difference in money between the Principal's Total Bid
Price and the amount for which the Obligee legally contracts with another party to fulfill the Contract is greater than
the penal sum, the Principal shall pay unto the Obligee the difference between the penal sum and the amount the
Obligee pays another to fulfill the Contract.

AND IT IS HEREBY DECLARED AND AGREED that the Surety shall be liable under this obligation as Principal, and
that nothing of any kind or nature whatsoever that will not discharge the Principal shall operate as a discharge or a
release of liability of the Surety.

IT IS HEREBY FURTHER DECLARED AND AGREED that this obligation shall be binding upon and inure to the
benefit of the Principal, the Surety and the Obligee and their respective heirs, executors, administrators, successors
and assigns.

SIGNED this _____ day of _____, 20 _____.

Principal: _____ Surety: _____

By: _____ By: _____

Title: _____ Title: _____

Address: _____ Address: _____

Telephone: () _____ Telephone: () _____

**Note: A power of attorney must be provided which appoints the Surety's true and lawful attorney-in-fact to
make, execute, seal and deliver this bid guaranty bond.**

AGREEMENT FORMS

This Page Intentionally Left Blank

CITY OF MERCER ISLAND, WASHINGTON
PUBLIC WORKS CONTRACT
FOR
2022 WATER SYSTEM IMPROVEMENTS PROJECT

THIS PUBLIC WORKS CONTRACT ("Contract") dated _____, is effective on the date the Contract is fully executed by the Parties. The Parties to this Contract are the CITY OF MERCER ISLAND, a Washington municipal corporation ("City" or "Owner"), and _____, a Washington _____ ("Contractor").

A. The City desires to retain an independent contractor to furnish all labor and materials necessary to perform work at 2022 Water System Improvements at Madrona Crest East Neighborhood, Mercer Island, Washington ("Property"); and

B. The Contractor has the requisite skill and experience to perform such work and has submitted a proposal dated _____ to complete such work ("Proposal").

NOW, THEREFORE, the parties ("Parties") agree to the following terms and conditions:

1. SERVICES BY CONTRACTOR

- 1.1 Description of Work. Contractor shall perform all work and furnish all tools, materials, supplies, equipment, labor and other items incidental thereto necessary for the construction and completion of the work, more particularly described in the Contract Documents for the 2022 Water System Improvements Project, including this Public Works Contract, the Contractor's completed Bid Form, the City's General Terms and Conditions (May 2020 ed.), any Supplemental and/or Special Conditions, Technical Specifications, Drawings and Addenda, which documents are incorporated by this reference, ("Work"), which Work shall be completed to the City's satisfaction, within the time period prescribed by the City and pursuant to the direction of the City Manager or his or her designee.
- 1.2 Completion Date. The Work shall be commenced within ten (10) days of receipt by the Contractor of the City's Notice to Proceed and shall be Substantially Completed by _____ (the "Contract Time") as may be extended in accordance with the Contract Documents. In the event the Work is not completed within the time specified, Contractor agrees to pay to the City liquidated damages in the amount set forth in Section 1.3 of this Contract.
- 1.3 Liquidated Damages. TIME IS OF THE ESSENCE OF THIS CONTRACT. Delays inconvenience the residents of Mercer Island and cost taxpayers undue sums of money, adding time needed for administration, engineering, inspection and supervision. It is impractical for the City to calculate the actual cost of delays. Accordingly, the Contractor agrees to pay liquidated damages as follows: Liquidated damages for failure to achieve timely Substantial Completion shall be in the amount of \$750.00 per day.
- 1.4 Performance Standard. Contractor shall perform the Work in a manner consistent with accepted practices for highly skilled and competent contractors performing this type of work in this area.

- 1.5 Compliance with Laws. Contractor shall perform the Work in accordance with all applicable federal, state and City laws, including but not limited to all City ordinances, resolutions, standards, or policies, as now existing, or hereafter adopted or amended, and obtain all necessary permits and pay all permit, inspection, or other fees, at its sole cost and expense.
- 1.6 Utility Location. Contractor is responsible for locating any underground utilities affected by the Work and is deemed to be an excavator for purposes of Chapter 19.122 RCW, as amended. Contractor shall be responsible for compliance with Chapter 19.122 RCW, including utilization of the "one call" locator system before commencing any excavation activities.
- 1.7 Air Environment. Contractor shall fully cover any and all loads of loose construction materials including without limitation, sand, dirt, gravel, asphalt, excavated materials, construction debris, etc., to protect said materials from air exposure and to minimize emission of airborne particles to the ambient air environment within the City of Mercer Island.

2. TERM

This Contract shall commence on the effective date of this Contract and continue until the Work is complete, and formally accepted by City, and all warranties have expired.

3. REQUISITE SKILL

The Contractor warrants that it has the requisite skill to complete the Work and is appropriately accredited and licensed by all applicable agencies and governmental entities, including but not limited to being registered to do business in the City of Mercer Island by obtaining a City of Mercer Island business registration. Contractor represents that it has visited the site and is familiar with all of the plans and specifications in connection with the completion of the Work.

4. COMPENSATION

- 4.1 Total Compensation. In consideration of the Contractor performing the Services, the City agrees to pay the Contractor an amount not to exceed _____ Dollars (\$_____), based on the Proposal submitted by Contractor dated _____ and as may be adjusted under the Contract Documents.
- 4.2 Contractor Responsible for Taxes. Except as otherwise stated in the Contract Documents, the Contractor shall be solely responsible for the payment of any taxes imposed by any lawful jurisdiction as a result of the performance and payment of this Contract.
- 4.3 Method of Payment. Payment by the City for the Work will only be made after the Work has been completed, a voucher or invoice is submitted in a form satisfactory to the City, and such invoice is approved by the appropriate City representative. Payment shall be made within thirty (30) days of receipt of such invoice or voucher unless otherwise set forth in the Bid Form. The Contractor's acceptance of such payment for the Work shall constitute full compensation for the performance of the Work. Invoices shall be submitted to:

City of Mercer Island
ATTN: George Fletcher, CIP Project Manager
9611 SE 36th Street

4.4 Retainage. Pursuant to Chapter 60.28 RCW, five percent (5%) of the Total Compensation shall be retained by the City to assure payment of Contractor's state taxes as well as payment of subcontractors, suppliers, and laborers. Upon execution of this Contract, Contractor shall complete, execute, and deliver to the City the Contractor's Retainage Agreement set forth in the Contract Documents. No payments shall be made by the City from the retained percentage fund ("Fund") nor shall the City release any retained percentage escrow account to any person, until the City has received from the Department of Revenue a certificate that all taxes, increases, and penalties due from the Contractor and all taxes due and to become due with respect to the Contract have been paid in full or that they are, in the Department's opinion, readily collectible without recourse to the State's lien on the retained percentage. Upon non-payment by the general contractor, any supplier or subcontractor may file a lien against the retainage funds, pursuant to Chapter 60.28 RCW. Subcontractors or suppliers are required to give notice of any lien within thirty (30) days of the completion of the Work and in the manner provided in RCW 39.08.030. Within sixty (60) days after completion of all Work on this Contract, the City shall release and pay in full the money held in the Fund, unless the City becomes aware of outstanding claims made against this Fund.

5. EQUAL OPPORTUNITY EMPLOYER

In all Contractor services, programs or activities, and all Contractor hiring and employment made possible by or resulting from this Contract, there shall be no discrimination by Contractor or by Contractor's employees, agents, subcontractors or representatives against any person because of sex, sexual orientation, age (except minimum age and retirement provisions), race, color, creed, national origin, marital status or the presence of any disability, including sensory, mental or physical handicaps, unless based upon a bona fide occupational qualification in relationship to hiring and employment. This requirement shall apply, but not be limited to the following: employment, advertising, layoff or termination, rates of pay or other forms of compensation, and selection for training, including apprenticeship. Contractor shall not violate any of the terms of Chapter 49.60 RCW, Title VII of the Civil Rights Act of 1964, the Americans With Disabilities Act, Section 504 of the Rehabilitation Act of 1973 or any other applicable federal, state, or local law or regulation regarding non-discrimination. Any material violation of this provision shall be grounds for termination of this Contract by the City and, in the case of the Contractor's breach, may result in ineligibility for further City agreements.

6. INDEPENDENT CONTRACTOR/CONFLICT OF INTEREST

It is the intention and understanding of the Parties that the Contractor shall be an independent contractor and that the City shall be neither liable nor obligated to pay Contractor sick leave, vacation pay or any other benefit of employment, nor to pay any social security or other tax which may arise as an incident of employment. The Contractor shall pay all income and other taxes as due. Industrial or any other insurance which is purchased for the benefit of the City, regardless of whether such may provide a secondary or incidental benefit to the Contractor, shall not be deemed to convert this Contract to an employment contract. It is recognized that Contractor may perform work during the Term of this Contract for other third parties; provided, however, that such performance of other work shall not conflict with or interfere with the Contractor's ability to perform the Work. Contractor agrees to resolve any such conflicts of interest in favor of the City.

7. INDEMNIFICATION

7.1 Indemnification and Hold Harmless.

- A. The Contractor shall protect, defend, indemnify, and hold harmless City, its elected officials, officers, agents, volunteers, and employees, from any and all claims, demands, suits, penalties, losses, damages, judgments, or costs of any kind whatsoever, including attorneys' fees (hereinafter "claims"), arising out of or in connection with the performance of this Contract except for injuries and damages caused by the sole negligence of the City. However, should a court of competent jurisdiction determine that this Contract is subject to RCW 4.24.115, then, in the event of liability for damages arising out of bodily injury to persons or damages to property caused by or resulting from the concurrent negligence of the Contractor and the City, its officers, officials, employees, and volunteers, the Contractor's liability hereunder shall be only to the extent of the Contractor's negligence.

- B. The Contractor's obligations under this section shall include, but not be limited to,
 - i. The duty to promptly accept tender of defense and provide defense to City at the Contractor's own expense.

 - ii. The duty to indemnify and defend City, its elected officials, officers, agents, and employees, from any claim, demand, and/or cause of action brought by or on behalf of any of its employees, or agents. The foregoing duty is specifically and expressly intended to constitute a waiver of the Contractor's immunity under Washington's Industrial Insurance Act, RCW Title 51, as respects City with a full and complete indemnity and defense of claims made by the Contractor's employees. The parties acknowledge that these provisions were mutually negotiated upon by them.

 - iii. To the maximum extent permitted by law, the Contractor shall indemnify and defend City, its elected officials, officers, agents and employees, from and be liable for all damages and injury which shall be caused to owners of property on or in the vicinity of the work or which shall occur to any person or persons or property whatsoever arising out of the performance of this Contract, whether or not such injury or damage is caused by negligence of the Contractor or caused by the inherent nature of the work specified.

- C. City may, in its sole discretion, (1) withhold amounts sufficient to pay the amount of any claim for injury, and/or (2) pay any claim for injury of which City may have knowledge, regardless of the formalities of notice of such claim, arising out of the performance of this Contract.

- D. Any amount withheld will be held until the Contractor secures a written release from the claimant, obtains a court decision that such claim is without merit, or satisfies any judgment on such claim. In addition, the Contractor shall reimburse and otherwise be liable for claims costs incurred by City, including, without limitation, costs for claims adjusting services, attorneys, engineering, and administration.

- E. In the event City incurs any judgment, award, and/or costs arising therefrom, including attorneys' fees, to enforce the provisions of this article, all such fees, expenses, and costs shall be recoverable from the Contractor.
- F. This provision has been mutually negotiated by the City and the Contractor.

7.2 Survival. The provisions of this Section 7 shall survive the expiration or termination of this Contract with respect to any event occurring prior to such expiration or termination.

8. INSURANCE

8.1 The Contractor agrees to carry without interruption from commencement of the Contractor's work through the term of the contract and for thirty (30) days after Physical Completion, unless otherwise indicated herein, the following insurance against claims for injuries to persons or damage to property which may arise from or in connection with the performance of the Work by Contractor, its agents, representatives, employees or subcontractors with a carrier having a current A.M. Best rating of not less than A:VII. The City, at its discretion, may require additional types and greater limits of insurance coverage commensurate with the risk associated with the performance of the Work.

- A. Workers' Compensation and Employer's Liability Insurance in amounts sufficient pursuant to the laws of the State of Washington.
- B. Commercial general liability insurance shall be written on a form at least as broad as Insurance Services Office (ISO) occurrence form CG 00 01 and shall cover liability arising from premises, operations, independent contractors, products-completed operations for three years following substantial completion of the Work, stop gap liability, personal injury and advertising injury, and liability assumed under an insured contract. The Commercial General Liability insurance shall be endorsed to provide the Aggregate Per Project Endorsement ISO form CG 25 03 05 09. There shall be no exclusion for liability arising from explosion, collapse, or underground property damage. The City shall be named as an additional insured under the Commercial General Liability insurance policy with respect to the Work performed for the City using ISO Additional Insured endorsement CG 20 10 10 01 and Additional Insured Completed Operations endorsement CG 20 37 10 01 or substitute endorsements providing coverage at least as broad, with limits of no less than \$2,000,000 each occurrence, \$2,000,000 general aggregate, and a \$2,000,000 products-completed operations aggregate limit.
- C. Automobile liability insurance covering all owned, non-owned, hired, and leased vehicles. Coverage shall be written on ISO form CA 00 01 or a substitute form providing equivalent liability coverage. If necessary, the policy shall be endorsed to provide contractual liability coverage with combined single limits for bodily injury and property damage of not less than \$1,000,000 per accident.
- D. Asbestos Abatement or Hazardous Materials. If asbestos abatement or hazardous materials work is performed, Contractor shall review coverage with the City Attorney's office and provide scope and limits of coverage that are appropriate for the scope of Work and are satisfactory to the City. Contractor shall not commence any Work until its coverage has been approved by the City Attorney's office.

- E. Builders Risk insurance covering interests of the City, the Contractor, Subcontractors, and Sub-subcontractors in the work. Builders Risk insurance shall be on a special perils policy form and shall insure against the perils of fire and extended coverage and physical loss or damage including flood, earthquake, theft, vandalism, malicious mischief, and collapse. The Builders Risk insurance shall include coverage for temporary buildings, debris removal, and damage to materials in transit or stored off-site. This Builders Risk insurance covering the work will have a deductible of \$5,000 for each occurrence, which will be the responsibility of the Contractor. Higher deductibles for flood and earthquake perils may be accepted by the City upon written request by the Contractor and written acceptance by the City. Any increased deductibles accepted by the City will remain the responsibility of the Contractor. The Builders Risk insurance shall be maintained until the City has granted substantial completion of the project. An installation floater may be acceptable in lieu of Builders Risk for renovation projects only if approved in writing by the City. Builders Risk insurance shall be written in the amount of the completed value of the project with no coinsurance provisions.
- 8.2 The City shall be named as additional insured on all such insurance policies, with the exception of workers' compensation coverages. The Contractor's insurance coverage shall be primary insurance as respect the City. Any insurance, self-insurance, or insurance pool coverage maintained by the City shall be excess of the Contractor's insurance and shall not contribute with it. If the Contractor maintains higher insurance limits than the minimums shown above, the City shall be insured for the full available limits of Commercial General and Excess or Umbrella liability maintained by the Contractor, irrespectively of whether such limits maintained by the Contractor are greater than those required by this Contract or whether any certificate of insurance furnished to the City evidences limits of liability lower than those maintained by the Contractor. Contractor shall provide certificates of insurance and amendatory endorsements, concurrent with the execution of this Contract, evidencing such coverage and, at City's request, furnish the City with copies of all insurance policies and with evidence of payment of premiums or fees of such policies. The Contractor shall provide the City and all Additional Insureds for this work with written notice of any policy cancellation within two business days of their receipt of such notice.
- 8.3 The Contractor shall cause each and every Subcontractor to provide insurance coverage that complies with all applicable requirements of the Contractor-provided insurance as set forth herein, except that the Contractor shall have sole responsibility for determining the limits of coverage required to be obtained by Subcontractors. The Contractor shall ensure that the City is an additional insured on each and every Subcontractor's Commercial General Liability insurance policy using an endorsement at least as broad as ISO CG 20 10 10 01 for ongoing operations and CG 20 37 10 01 for completed operations.
- 8.4. Failure on the part of the Contractor to maintain the insurance as required shall constitute a material breach of contract, upon which the City may, after giving five business days notice to the Contractor to correct the breach, immediately terminate the Contract or, at its discretion, procure or renew such insurance and pay any and all premiums in connection therewith, with any sums so expended to be repaid to the City on demand, or at the sole discretion of the City, offset against funds due the Contractor from the City.
- 8.5 Waiver of Subrogation. The Contractor and the City waive all rights against each other, any of their Subcontractors, Sub-subcontractors, agents, and employees, each of the other, for

damages caused by fire or other perils to the extent covered by Builders Risk insurance or other property insurance obtained pursuant to the Insurance Requirements Section of this Contract or other property insurance applicable to the work. The policies shall provide such waivers by endorsement or otherwise.

- 8.6 The Contractor's maintenance of insurance, its scope of coverage and limits as required herein shall not be construed to limit the liability of the Contractor to the coverage provided by such insurance, or otherwise limit the City's recourse to any remedy available at law or in equity.
- 8.7 The provisions of this Section shall survive the expiration or termination of this Contract with respect to any event occurring prior to such expiration or termination.

9. PERFORMANCE/PAYMENT BOND OR ADDITIONAL RETAINAGE

Pursuant to RCW 39.08.010, Contractor shall provide Performance Bond and Payment Bond each in an amount equal to 100% of the amount of this Contract to cover the performance of all provisions of this Contract and the payment of all laborers and suppliers. The Contract bonds shall be in a form set forth in the Contract Documents. The Contract bond shall assure that the Contractor will faithfully perform all of the provisions of the Contract as well as pay all laborers, mechanic subcontractors, materialmen, and suppliers. Contractor's obligations under this Contract shall not be limited to the bond amount.

Alternatively, pursuant to RCW 39.08.010, on contracts of Fifty-Five Thousand Dollars (\$55,000) or less, at the option of the Contractor, the City may, in lieu of a bond, retain ten percent (10%) of the Contract amount for a period of thirty (30) days after the date of final acceptance, or until receipt of all necessary releases from the Department of Revenue and the Department of Labor and Industries and settlement of any liens filed under Chapter 60.28 RCW, whichever is later.

10. SAFETY

Contractor shall take all necessary precautions for the safety of its employees on the work site and shall comply with all applicable provisions of federal, state, and municipal safety and health laws and codes, including without limitation, all OSHA/WISHA requirements, Safety and Health Standards for Construction Work (Chapter 296-155 WAC), General Safety and Health Standards (Chapter 296-24 WAC), and General Occupational Health Standards (Chapter 296-62 WAC). Contractor shall erect and properly maintain, at all times, all necessary guards, barricades, signals, and other safeguards at all unsafe places at or near the Work for the protection of its employees and the public, safe passageways at all road crossings, crosswalks, street intersections, post danger signs warning against known or unusual hazards and do all other things necessary to prevent accident or loss of any kind. Contractor shall protect from damage all water, sewer, gas, steam or other pipes or conduits, and all hydrants and all other property that is likely to become displaced or damaged by the execution of the Work. The Contractor shall, at its own expense, secure and maintain a safe storage place for its materials and equipment and is solely responsible for the same.

11. PREVAILING WAGES

- 11.1 Wages of Employees. This Contract is subject to the minimum wage requirements of Chapter 39.12 of the Revised Code of Washington, as now existing or hereafter amended or supplemented. In the payment of hourly wages and fringe benefits to be paid to any of Contractor's laborers, workpersons and/or mechanics, Contractor shall not pay less than the

"prevailing rate of wage" for an hour's work in the same trade or occupation in the locality within the State of Washington where such labor is performed, as determined by the Industrial Statistician of the Department of Labor and Industries of the State of Washington. Prevailing wages paid pursuant to this Agreement shall be the prevailing wage rates which are in effect on the date when the bids, proposals, or quotes were required to be submitted to the City.

The State of Washington prevailing wage rates applicable for this public works project, which is located in King County, may be found at the following website address of the Department of Labor and Industries: <https://lni.wa.gov/licensing-permits/public-works-projects/prevailing-wage-rates/>. A copy of the applicable prevailing wage rates is also available for viewing at the office of the City located at 9611 SE 36th St, Mercer Island, WA 98040. Upon request, the City will mail a hard copy of the applicable prevailing wages for this project.

- 11.2 Reporting Requirements. Contractor shall comply with all reporting requirements of the Department of Labor and Industries of the State of Washington. Upon the execution of this Contract, Contractor shall complete and file a Statement of Intent to Pay Prevailing Wages with the Department of Labor and Industries. If requested by the City, the Contractor shall provide certified payroll records for its employees and the employees of its subcontractors. Upon completion of the Work, Contractor shall complete and file an Affidavit of Wages Paid with the Department of Labor and Industries. Contractor shall deliver copies of both the Statement of Intent to Pay Prevailing Wages and the Affidavit of Wages Paid, certified by the Department of Labor and Industries, to the City.

12. SUBCONTRACTOR RESPONSIBILITY

Contractor shall verify responsibility criteria for each first-tier subcontractor, and a subcontractor of any tier that hires other subcontractors must verify responsibility criteria for each of its subcontractors. Verification shall include that each subcontractor, at the time of subcontract execution, meets the responsibility criteria listed in the Instructions to Bidders and possesses an electrical contractor license, if required by chapter 19.28 RCW, or an elevator contractor license, if required by chapter 70.87 RCW. This verification requirement must be included in every public works subcontract or every tier.

13. OWNERSHIP OF DOCUMENTS

All originals and copies of work product, including plans, sketches, layouts, designs, design specifications, records, files computer disks, magnetic media, all finished or unfinished documents or material which may be produced or modified by Contractor while performing the Work shall become the property of the City and shall be delivered to the City at its request.

14. CONFIDENTIALITY

If it is necessary to provide proprietary information, the Contractor shall clearly mark the information on each page of the document(s) as "Proprietary and Confidential". The City is subject to laws regarding the disclosure of public records and document. Proposals and other materials, submitted by the Contractor become public record and may be subject to public disclosure, in whole or in part, and may be released by the City in the event of a request for disclosure. In the event the City receives a public record request for information and the Contractor has marked the requested document as "Proprietary and Confidential", the City shall notify the Contractor of such request and withhold disclosure of such information for not less than five (5) business days, to permit the Contractor to seek judicial protection

of such information; provided that the Contractor shall be solely responsible for all attorney fees and costs in such action and shall save and hold harmless the City from any costs, attorneys fees or penalty assessments under Chapter 42.56 RCW for withholding or delaying public disclosure of such information.

15. BOOKS AND RECORDS

The Contractor agrees to maintain books, records, and documents which sufficiently and properly reflect all direct and indirect costs related to the performance of this Contract and such accounting procedures and practices as may be deemed necessary by the City to assure proper accounting of all funds paid pursuant to this Contract. These records shall be subject at all reasonable times to inspection, review or audit by the City, its authorized representative, the State Auditor, or other governmental officials authorized by law to monitor this Contract.

16. CLEAN UP

At any time ordered by the City and immediately after completion of the Work, the Contractor shall, at its own expense, clean up and remove all refuse and unused materials of any kind resulting from the Work. In the event the Contractor fails to perform the necessary clean up, the City may, but in no event is it obligated to, perform the necessary clean up and the costs thereof shall be immediately paid by the Contractor to the City and/or the City may deduct its costs from any remaining payments due to the Contractor.

17. GENERAL PROVISIONS

This Contract, the Contract Documents and any supporting contract documents contain all of the agreements of the Parties with respect to any matter covered or mentioned in this Contract and no prior agreements or understandings shall be effective for any purpose. No provision of this Contract may be amended except by written agreement of the Parties. Any provision of this Contract which is declared invalid, void or illegal shall in no way affect, impair, or invalidate any other provision hereof and such other provisions shall remain in full force and effect. The Contractor shall not transfer or assign, in whole or in part, any or all of its obligations and rights hereunder without the prior written consent of the City. In the event the City consents to any such assignment or transfer, such consent shall in no way release the Contractor from any of its obligations or liabilities under this Contract. Subject to the preceding sentence, this Contract shall be binding upon and inure to the benefit of the Parties' successors in interest, heirs, and assigns. In the event the City or the Contractor defaults on the performance of any terms in this Contract, and the Contractor or City places the enforcement of the Contract or any part thereof, or the collection of any monies due, in the hands of an attorney, or files suit, each Party shall pay all its own attorneys' fees and expenses. The venue for any dispute related to this Contract shall be King County, Washington. Failure of the City to declare any breach or default immediately upon occurrence thereof, or delay in taking any action in connection with, shall not waive such breach or default. This Contract shall be governed by and interpreted in accordance with the laws of the State of Washington. Each individual executing this Contract on behalf of the City and Contractor represents and warrants that such individuals are duly authorized to execute this Contract. Time is of the essence of this Contract and each and all of its provisions in which performance is a factor. Adherence to completion dates is essential to the Contractor's performance of this Contract.

IN WITNESS WHEREOF, the Parties have executed this Contract the ____ day of ____, 20__.

CONTRACTOR:

(Name of Contractor)

By: _____
(Signature)

(Full Legal name and Title)

Address:

Phone:

Email:

CITY:

CITY OF MERCER ISLAND

By: _____
Jessi Bon, City Manager

Attest:

By: _____
Andrea Larson, City Clerk

Approved as to form:

By: _____
Bio Park, City Attorney

PERFORMANCE BOND

To City of Mercer Island, WA

Bond No. _____

The City of Mercer Island, Washington has awarded to _____ (Principal), a contract for the construction of the project designated as _____, Project No. _____, in Mercer Island, Washington (Contract), and said Principal is required to furnish a bond for performance of all obligations under the Contract.

The Principal, and _____ (Surety), a corporation, organized under the laws of the State of _____ and licensed to do business in the State of Washington as surety and named in the current list of "Surety Companies Acceptable in Federal Bonds" as published in the Federal Register by the Audit Staff Bureau of Accounts, U.S. Treasury Dept., are jointly and severally held and firmly bound to the City, in the sum of _____ US Dollars (\$ _____) Total Contract Amount, subject to the provisions herein.

This statutory payment bond shall become null and void, if and when the Principal, its heirs, executors, administrators, successors, or assigns shall well and faithfully perform all of the Principal's obligations under the Contract and fulfill all terms and conditions of all duly authorized modifications, additions, and changes to said Contract that may hereafter be made, at the time and in the manner therein specified; and if such performance obligations have not been fulfilled, this bond shall remain in force and effect.

The Surety for value received agrees that no change, extension of time, alteration or addition to the terms of the Contract, the specifications accompanying the Contract, or to the work to be performed under the Contract shall in any way affect its obligation on this bond, and waives notice of any change, extension of time, alteration or addition to the terms of the Contract or the work performed. The Surety agrees that modifications and changes to the terms and conditions of the Contract that increase the total amount to be paid the Principal shall automatically increase the obligation of the Surety on this bond and notice to Surety is not required for such increased obligation.

This bond may be executed in two (2) original counterparts, and shall be signed by the parties' duly authorized officers. This bond will only be accepted if it is accompanied by a fully executed and original power of attorney for the office executing on behalf of the surety.

PRINCIPAL

SURETY

Principal Signature Date

Surety Signature Date

Printed Name Date

Printed Name Date

Title

Title

Name, address, and telephone of local office/agent of Surety Company is:

This Page Intentionally Left Blank

PAYMENT BOND
to City of Mercer Island, WA

Bond No _____

The City of Mercer Island, Washington has awarded to _____ (Principal), a contract for the construction of the project designated as _____,
Project No. _____, in Mercer Island, Washington (Contract), and said Principal is required under the terms of that Contract to furnish a payment bond in accord with Title 39.08 Revised Code of Washington (RCW) and (where applicable) 60.28 RCW.

The Principal, and _____ (Surety), a corporation organized under the laws of the State of _____ and licensed to do business in the State of Washington as surety and named in the current list of "Surety Companies Acceptable in Federal Bonds" as published in the Federal Register by the Audit Staff Bureau of Accounts, U.S. Treasury Dept., are jointly and severally held and firmly bound to the City, in the sum of _____
US Dollars (\$) _____) Total Contract Amount, subject to the provisions herein.

This statutory payment bond shall become null and void, if and when the Principal, its heirs, executors, administrators, successors, or assigns shall pay all persons in accordance with RCW 39.08, 39.12, and 60.28 including all workers, laborers, mechanics, subcontractors, and materialmen, and all person who shall supply such contractor or subcontractor with provisions and supplies for the carrying on of such work, and all taxes incurred on said Contract under Titles 50 and 51 RCW and all taxes imposed on the Principal under Title 82 RCW; and if such payment obligations have not been fulfilled, this bond shall remain in full force and effect.

The Surety for value received agrees that no change, extension of time, alteration or addition to the terms of the Contract, the specifications accompanying the Contract, or to the work to be performed under the Contract shall in any way affect its obligation on this bond, and waives notice of any changes, extension of time, alteration or addition to the terms of the Contract or the work performed. The Surety agrees that modifications and changes to the terms and conditions of the Contract that increase the total amount to be paid the Principal shall automatically increase the obligation of the Surety on this bond and notice to Surety is not required for such increased obligation.

This bond may be executed in two (2) original counterparts, and shall be signed by the parties' duly authorized officers. This bond will only be accepted if it is accompanied by a fully executed and original power of attorney for the office executing on behalf of the surety.

PRINCIPAL

SURETY

Principal Signature _____ Date _____

Surety Signature _____ Date _____

Printed Name _____ Date _____

Printed Name _____ Date _____

Title _____

Title _____

Name, address, and telephone of local office/agent of Surety Company is:

This Page Intentionally Left Blank

RETAINAGE AGREEMENT

Contract Title 2022 WATER SYSTEM IMPROVEMENTS PROJECT
Contract Date _____
Contractor Name _____
Contractor Address _____
Contractor Phone _____
Contractor Federal ID # _____

State Law on How Contract Retainage Monies can be Reserved:

RCW 60.28.010 Retained percentage, labor and material Contracts for public improvements or work other than for professional services, provides that there shall be reserved by the city from the monies earned by the contractor on estimates during the progress of the improvement or work, a sum of five percent of such estimates, said sum to be retained by the city as a trust fund for the protection and payment of any persons performing work or supplying provisions or supplies during the work. The monies reserved for contract retainage may be reserved by the contractor choosing one of the following four options:

All investments selected below are subject to City approval.

Contractor Options (Contractor shall place an "x" in one of the boxes below.)

- (a) Retained in a non-interest bearing fund by the public body until released in accordance with applicable state statutes;
- (b) Deposited by the public body in an interest bearing account in a bank, mutual savings bank, or savings and loan association, not subject to withdrawal until released in accordance with applicable state statutes, provided that interest on such account shall be paid to the contractor;
- (c) Placed in escrow with a bank or trust company by the public body until released in accordance with applicable state statutes. The cost of the investment program and the risk thereof is to be borne entirely by the contractor.
- (d) Contractor may submit a Retainage Bond equal to 5% of the total awarded bid amount for all schedules to be held by the public body until released in accordance with applicable state statutes.

Contractor's Bank

If Contractor selects options (b) or (c) above, Contractor shall designate below the bank in which the retainage is to be deposited:

ACCOUNT NO. _____
BANK NAME _____
BANK ADDRESS _____
BANK PHONE # _____

Agreement

Contractor and City agree that all or part of the monies in the account can only be approved for disbursement by Bank to Contractor upon written authorization of the City Finance Director, or his/her authorized designee.

By _____ By _____
City of Mercer Island Contractor

Date _____ Date _____

This Page Intentionally Left Blank

GENERAL TERMS & CONDITIONS

This Page Intentionally Left Blank

**CITY OF MERCER ISLAND
GENERAL TERMS AND CONDITIONS
MAY 2020 EDITION
TABLE OF CONTENTS**

Article 1: GENERAL PROVISIONS	1
1.1 Definitions	1
1.2 Intent and Interpretation of the Documents	4
1.3 Clarification of Drawings and Detail Drawings.....	5
Article 2: CITY	5
2.1 Authority.....	5
2.2 Information Supplied by City	6
2.3 Work by City or Separate Contractors	6
Article 3: CONTRACTOR	6
3.1 Contractor Representations	6
3.2 General Duties	7
3.3 Duty to Inspect Contract Documents	7
3.4 Contractor’s Supervision and Employees	8
3.5 Subcontractors and Suppliers	8
3.6 Schedule of Working Hours	9
3.7 Record Documents	9
3.8 Cost Records	10
3.9 Maintenance and Inspection of Documents	10
3.10 Maintenance and Site Cleanup	12
3.11 Protection of Existing Structures, Equipment, Vegetation, Utilities, and Improvements	13
3.12 Permits, Laws, Regulations and Taxes	13
3.13 Patents and Royalties	14
3.14 Contractor’s Certification	14
3.15 Deviation from Contract	15
3.16 Operations, Material Handling, and Storage Areas	15
3.17 Contractor’s Overall Responsibility For Protection of Work, Property, and Persons	15
3.18 Protection of Persons.....	16
3.19 Safety Program	16
3.20 Archaeological and Historical Preservation	17
3.21 Water Pollution Control Requirements.....	17
3.22 Easements	17
3.23 Title VI Compliance and Assurance.....	17
Article 4: ADMINISTRATION OF THE CONTRACT	18
4.1 Time of Essence	18
4.2 Work Progress	18
4.3 Schedule of Values	18
4.4 Project Schedule	19
4.5 Submittals	20
4.6 Requests for Information	21
4.7 Tests, Inspections, and Access to the Work	22
4.8 Correction of Work or Damaged Property	23
4.9 Substitution of Products & Processes	23
4.10 Increased or Decreased Quantities	24
Article 5: CHANGES TO THE CONTRACT	25
5.1 General	25
5.2 Contractor’s Request for a Change Order	26
5.3 Differing Site Conditions	27
5.4 Suspension of Work.....	28
5.5 Force Majeure.....	29
5.6 Change Orders	29

5.7	City Request for a Change Proposal.....	30
Article 6: TIME AND PRICE ADJUSTMENTS		30
6.1	Change in the Contract Time	30
6.2	Change in the Contract Price.....	31
6.3	Method to Calculate Adjustments to Contract Price.....	33
6.4	Allowable Costs	35
Article 7: PAYMENT AND COMPLETION		37
7.1	Applications for Payment	37
7.2	Payments.....	38
7.3	Payment Withheld.....	38
7.4	Title.....	39
7.5	Substantial Completion	39
7.6	Final Inspection.....	40
7.7	Requirements for Final Application For Payment.....	40
7.8	Completion/Final Acceptance	40
7.9	Warranty and Guaranty	41
7.10	Prior Occupation	41
Article 8: TERMINATION		42
8.1	City's Right to Terminate Contract	42
8.2	City's Right to Stop the Work for Cause	44
Article 9: CLAIMS AND LITIGATION		44
9.1	Contractor Claims	44
9.2	Contractor's Burden of Proof on Claim	46
9.3	Litigation.....	46
Article 10: MISCELLANEOUS.....		46
10.1	Compensation, Wages, Benefits and Taxes.....	46
10.2	Prevailing Wages.....	47
10.3	Successors and Assigns.....	47
10.4	Third Party Agreements	47
10.5	Nonwaiver of Breach.....	47
10.6	Notice to City of Labor Disputes.....	47
10.7	Headings.....	47
10.8	Choice of Law	47
10.9	Severability	48

ARTICLE 1: GENERAL PROVISIONS

1.1 DEFINITIONS

- A. **“Addendum”** or **“Addenda.”** Alteration or clarification of the plans or specifications provided to bidders by City prior to bid time, which becomes part of the Contract Documents when the Contract is executed.
- B. **“Claim.”** A written demand by the Contractor seeking (1) a change to Contract Price; (2) a change of Contract Time; (3) a payment of money or damages; and/or, (4) any other relief arising out of or relating to this Contract.
- C. **“Change Order.”** A written instrument designated to be a Change Order which alters the Contract, and identifies the following: (1) a change in the Work; (2) a change in Contract Price; and/or (3) a change in Contract Time.
- D. **“Change Proposal.”** A document prepared by the Contractor at the request of City, which proposes changes to the Work and/or changes to the Contract Price and/or Contract Time. City initiates all requests for Change Proposals.
- E. The **“Contract”** or **“Contract Documents.”** The entire integrated agreement between City and the Contractor for the performance of the Work in accordance with the Contract Documents. The Contract Documents include the following:
 - 1. The signed Agreement between City and Contractor (the “Public Works Contract”);
 - 2. The Contractor’s completed Bid Form;
 - 3. The City’s General Terms and Conditions (May 2020 ed.);
 - 4. Any Supplemental or Special Conditions.
 - 5. Technical Specifications;
 - 6. Drawings;
 - 7. Addenda; and
 - 8. Any Change Orders.
- F. **“Contract Execution.”** occurs when City Manager or his/her designee signs the Contract, which shall only occur after the Contractor signs the Contract.
- G. **“Contract Price”** means the total amount payable by City to the Contractor for performance of the Work in accordance with the Contract.
- H. **“Contract Time.”** The number of days or the specific date set forth in the Contract to achieve Substantial Completion of the Work.
- I. **“Contract Work”** or **“Work.”** The labor, supervision, materials, equipment, supplies, services, other items, and requirements of the Contract necessary for the execution, completion and performance of all requirements of the Contract by the Contractor to the satisfaction of City.
- J. **“Contractor.”** The individual, association, partnership, firm, company, corporation, or combination thereof, including joint ventures, contracting with City to do the Contract Work.

- K. **“Critical Path.”** The longest, continuous sequence of interrelated activities that begins at the start of the Project (Notice to Proceed) and extends to Substantial Completion of the Project. These activities are critical because delay to an activity on this path will extend Contract Time.
- L. **“Day.”** A calendar day, unless otherwise specified.
- M. **“Differing Site Conditions.”** (1) Subsurface or latent physical conditions at the site which differ materially from those indicated in the Contract Documents (Type I), or (2) Unknown physical conditions at the Site, of an unusual nature, which differ materially from those ordinarily encountered and generally recognized as inherent in the construction activities of the character provided for in the Contract (Type II).
- N. **“Engineer.”** The City representative who administers the Contract for the City.
- O. **“Final Acceptance.”** Written acceptance of the Project by City.
- P. **“Force Majeure.”** An event that is unforeseeable at the time of Contract Execution and that is beyond the reasonable control of the Contractor and City and includes:
1. Natural Disaster declared by Governor of Washington or President of the United States, including but not limited to earthquakes;
 2. Acts or omissions of any government entity acting within its governmental capacity;
 3. Fire and/or flood for which the Contractor or its Subcontractors is not responsible;
 4. Quarantine or epidemic;
 5. Strike or defensive lockout;
 6. Unusually Severe Weather Conditions; and
 7. Acts of terrorism.
- Q. **“Hazardous Material.”** Any pollutant, contaminant, toxic or hazardous waste, dangerous substance, potentially dangerous substance, noxious substance, toxic substance, flammable material, explosive material, radioactive material, urea formaldehyde foam insulation, asbestos, PCBs, or any other substances the removal of which is required, or the manufacture, preparation, production, generation, use, maintenance, treatment, storage, transfer, handling, or shipment of which is restricted, prohibited, regulated, or penalized by any and all federal, state, City, or municipal statutes or laws and regulations promulgated thereunder, now or at any time hereafter in effect, including, but not limited to, the Comprehensive Environmental Response, Compensation, and Liability Act (42 U. S. C. §§ 9601, *et seq.*), the Hazardous Materials Transportation Act (49 U. S. C. §§ 1801, *et seq.*), the Resource Conservation and Recovery Act (42 U. S. C. §§ 6901, *et seq.*), the Federal Water Pollution Control Act (33 U. S. C. §§ 1251, *et seq.*), the Clean Air Act (42 U. S. C. §§ 7401, *et seq.*), the Toxic Substances Control Act, as amended (15 U. S. C. §§ 2601, *et seq.*), the Occupational Safety and Health Act (29 U. S. C. §§ 651, *et seq.*, and the Model Toxics Control Act (RCW 70.105), or similar state or local statute or code), as the laws have been amended and supplemented.
- R. **“City”** or **“Owner”** may be used interchangeably and refer to the City of Mercer Island.

- S. **“Notice.”** A written document issued by the Engineer or Contractor’s Representative which is submitted to the other party and delivered by:
1. Depositing in the U. S. Mail (or other method of commercial express mail), which notice shall be effective on the date of receipt;
 2. Service on the Parties’ representative or at the Contractor’s home office or field office, which notice shall be effective on the date of service; or,
 3. Facsimile to the Parties’ representative or Contractor’s home office or field office, which notice shall be effective upon receipt.
- T. **“Notice To Proceed.”** A written directive issued by City authorizing the Contractor to perform some or all of the Work.
- U. **“Overhead.”** Charges that may be incurred or allocated in support of the Contract but are not part of the cost of directly performing the physical Contract construction activity. Overhead includes Site or Field Overhead and Home Office Overhead.
1. **Site or Field Office Overhead**
Site or Field Overhead costs are typically those costs that are related to, but are not limited to supervision, including general foremen and their supervisors, planners, schedulers, engineers, managers, etc. and the direct payroll costs of their project-related service, clerical salaries and their direct payroll costs, the costs of all vehicles, travel, meal and lodging costs associated with those personnel, Site or Field office and utility expense, expenses associated with all regulatory compliance, Hand and Other Small Tools provided by the Contractor for the use of its forces, all expendable supplies, and all other items incidental to or integral in supporting the physical completion of the Work.
 2. **Home Office Overhead**
Home office Overhead costs are typically those that include all general office expenses. Such costs include, but are not limited to those associated with officer and office salaries and related payroll taxes and benefits, costs of office occupancy and maintenance, all supporting services (such as utilities, office machines computers, and related items and support) related to the home office function, business taxes and licenses, and all such other costs necessary to operate the business entity. Home office overhead includes unabsorbed home office overhead.
 3. In addition to the above, whether treated as Site or Field Overhead or as Home Office Overhead, costs of any and all bonds, insurance(s), and taxes associated with this Contract are to be considered as Overhead. All items as those identified above are to be treated as Overhead for this purpose regardless of how the Contractor chooses to account for them in its books of account.
 4. Under no circumstances shall City pay the Contractor for direct or allocated costs or charges for officer bonus and profit sharing, project personnel bonuses, charitable contributions, income taxes, or any costs relating to illegal activity.
- V. **“Parties.”** The Contractor and City.
- W. **“Project.”** All activity relative to this Contract including activity of the Contractor, its Subcontractors, and City.

- X. **“Request for Change Order.”** A document, designated as a Request for a Change Order, prepared by the Contractor requesting either (1) a change in Contract Price; (2) a change in Contract Time; (3) a change in t Work; (4) a payment of money or damages; and/or, (5) any other relief arising out of or relating to this Contract.
- Y. **“Request for Information.”** A request from the Contractor to City seeking an interpretation or a clarification of some requirement of the Contract Documents.
- Z. **“Site” or “Project Site.”** The location, at which construction, equipment or services furnished by the Contractor under the Contract will be performed, completed and/or delivered.
- AA. **“Subcontractor.”** An individual, firm, partnership, or corporation having a contract, purchase order, or agreement with the Contractor, or with any Subcontractor of any tier for the performance of any part of the Contract. When City refers to Subcontractor(s) in this document, for purposes of this document and unless otherwise stated herein, the term Subcontractor(s) includes, at every level and/or tier, all subcontractors and subconsultants.
- BB. **“Supplier(s).”** Any person or firm who is not performing work or supplying labor on Site and is engaged in the business of supplying a manufactured product or resource to City, Contractor, or Subcontractors. The term Suppliers includes materialmen, manufacturers, and fabricators.
- CC. **“Substantial Completion.”** That stage in the progress of the Work where:
 1. City has full and unrestricted use and benefit of the Project for the purpose intended;
 2. All the systems and parts of the Contract Work are functional;
 3. Utilities are connected and operate normally;
 4. Only minor incidental work or correction or repair remains to complete all Contract requirements; and
 5. The City has received all certificates of occupancy and any other permits, approvals, licenses and other documents from any governmental authority with jurisdiction necessary for beneficial occupancy of the project.

1.2 INTENT AND INTERPRETATION OF THE DOCUMENTS

- A. The Contract Documents constitute the entire and integrated agreement between the parties hereto and supersede all prior negotiations, representations, or agreements, either written or oral.
- B. The Contract Documents shall not be construed to create a contractual relationship between any parties other than City and the Contractor. No contract between City and a third party shall be construed to create any duty on the part of City or such third party to the Contractor. The Contractor is not an intended or incidental beneficiary of any promises made in City’s contract with a third party, if any.
- C. The Contract Documents are intended to be complementary. What is required by one part of the Contract shall be as binding as if required by all. Should any conflict or inconsistency be found in the Contract Documents, the provision imposing the more expensive duty or obligation on the Contractor shall take precedence.

- D. The words “similar,” “typical” (or other equivalents) shall mean nearly corresponding or having a likeness. Such words shall not be construed to mean that all parts of the Work referred to are identical or substantially identical, or that such elements of the Work are connected identically or substantially identically to the rest of the Work. The Contractor has the responsibility to determine all details of the Work in relation to their location and connection to other parts of the Work. The singular includes the plural and vice versa. Male includes female and vice versa.
- E. The organization of the specifications into divisions, provisions and articles and the organization of the drawings shall not control the Contractor in dividing the Work among Subcontractors or in establishing the extent of Work to be performed by any trade.

1.3 CLARIFICATION OF DRAWINGS AND DETAIL DRAWINGS

- A. Where on any drawing a portion of the Work is drawn out and the remainder is indicated in outline, the drawn out parts shall apply also to other similar portions of the Work. Where ornament or other detail is indicated by starting only, such detail shall be continued throughout the courses or parts in which it occurs and shall apply to all other similar parts of the Work, unless otherwise indicated.
- B. With regard to drawings the following shall apply:
 - 1. Written dimensions shall be followed; drawings may not be to scale.
 - 2. Figure dimensions on drawings shall govern over scale dimensions; and detail drawings shall govern over general drawings.

ARTICLE 2: CITY

2.1 AUTHORITY

- A. Unless City, in writing, indicates otherwise, the authority to (1) commit to or bind City to any Change Orders or change in the Work, Contract Price and/or Contract Time; or (2) sign the Contract or Change Orders rests solely in the City Manager or his or her designee.
- B. The Engineer shall have the authority to administer the Contract. Administration of the Contract by the Engineer includes but is not limited to:
 - 1. Receiving all correspondence and information from the Contractor;
 - 2. Issuing request for Change Proposals;
 - 3. Responding to Requests For Information;
 - 4. Reviewing the schedule of values, project schedules, submittals, testing and inspection reports, substitution requests, and other documentation submitted by the Contractor;
 - 5. Negotiating Change Proposals and Change Orders;
 - 6. Recommending Change Orders for approval by the City Manager or its designee;
 - 7. Issuing decisions with respect to Requests for Change Orders and Claims;
 - 8. Processing payment requests submitted by the Contractor, and recommending payment;

9. Monitoring the quality of the Work, rejecting noncompliant Work, and recommending acceptance of the Work;
 10. Transmitting executed Change Orders, amendments, and other Contract correspondence to the Contractor; and
 11. Performing all other contract administrative functions.
- C. All correspondence, questions, and/or documentation shall be submitted to the Engineer.
- D. The Engineer may designate representatives to perform functions under the Contract, such as review and/or inspection and acceptance of supplies, services, including construction, and other functions of a technical or administrative nature.

2.2 INFORMATION SUPPLIED BY CITY

- A. Unless otherwise specifically provided in the Contract, surveys and site information provided by City are intended to describe the general physical characteristics of the Site. City does not represent that this information is complete or sufficient for the Contractor's performance of the Work.
- B. City shall furnish to the Contractor a copy of the Contract Documents. The Contractor shall pay City for any additional copies of Contract Documents.

2.3 WORK BY CITY OR SEPARATE CONTRACTORS

City reserves the right to perform work not included in the Contract or to let other contracts in connection with this Project. The Contractor shall coordinate its Work with City and other City contractors and, at City's request, participate in meetings for the purpose of coordinating the Contractor's construction schedule with those of other contractors at no additional cost to City.

ARTICLE 3: CONTRACTOR

3.1 CONTRACTOR REPRESENTATIONS

The Contractor makes the following representations to City:

- A. Before submission of its bid, the Contractor has:
1. Carefully reviewed the Contract Documents, and visited and examined the Site;
 2. Become familiar with the general and local conditions in which the Work is to be performed, and satisfied itself as to the nature, location, character, quality and quantity of Contract Work, the labor, materials, equipment, goods, supplies, work, services and other items to be furnished and all other requirements of the Contract Documents, as well as the surface and reasonably ascertainable subsurface conditions and other matters that may be encountered at the Site or affect performance of the Work or the cost or difficulty thereof;
 3. Become familiar with and satisfied itself as to the conditions bearing upon transportation, disposal, handling, and storage of materials; and
 4. Become familiar with and satisfied itself as to the availability of labor, water, electric power, and roads; and the uncertainties of access, traffic, parking and weather. Any failure of the Contractor to take the action described in this provision (3.0) or elsewhere in the Contract Documents will not relieve the Contractor from responsibility for estimating properly the difficulty and cost of

successfully performing the Work, or for proceeding to successfully perform the Work without additional expense to City.

- B. The Contract Price is reasonable compensation for the Work and the Contract Time is adequate for the performance of the Work as represented by the Contract, site visit, and the general conditions (including but not limited to weather, site, soil) known or reasonably anticipated for the Site.

3.2 GENERAL DUTIES

- A. The Contractor shall give sufficient supervision to the Work, using its best skill and attention. The Contractor is on notice that City will be relying on the accuracy, competence and completeness of the Work. The Contractor shall supervise and be solely responsible for the proper performance of the Work in accordance with the Contract, including the construction means, methods, techniques, sequences, procedures, and for coordination of all portions of the Work.
- B. Unless specified elsewhere in the Contract, the Contractor shall provide and pay for all labor, materials, equipment, tools, construction machinery, utilities, transportation, and other facilities and services (including federal and state tax, industrial insurance, social security liability and all other applicable taxes) necessary for the proper execution and completion of the Work.
- C. The Contractor shall also provide sufficient staffing and supervision to process Requests for Information, Change Proposals, Submittals, Change Orders, close out documentation, and to perform all other requirements of the Contract and all Work.
- D. The Contractor shall lay out its Work from baselines and benchmarks indicated in the Contract, if any, and shall be responsible for the accuracy of all field measurements and surveys used in the lay out.

3.3 DUTY TO INSPECT CONTRACT DOCUMENTS

- A. The Contractor shall carefully study and compare all Contract Documents and check the conditions, dimensions, and instructions as stated therein. Contractor will not be required to provide professional services which constitute the practice of architecture and engineering except to the extent provided for in the technical specifications and drawings.
- B. The Contractor shall immediately notify City in writing of any:
 - 1. Error, inconsistency, or omission in the Contract Documents that a reasonable contractor knew or through the exercise of reasonable diligence should have discovered under the same and similar circumstances;
 - 2. Requirement in the Contract Documents that conflict with any local, state, and federal laws, regulations and/or permits, licenses, and easement conditions that a reasonable contractor knew or through the exercise of reasonable diligence should have discovered under the same and similar circumstances.
- C. The Contractor should not proceed with the work in question until the Contractor receives written direction from the Engineer.
- D. If the Contractor proceeds with the work in question without written direction from the Engineer, the Contractor shall be responsible for any costs or damages associated with:

1. Fines or penalties;
2. Demolition, tear out, removal, cleanup, remediation, or fixing the work in question; and
3. Delay, disruption, and loss of productivity.

3.4 CONTRACTOR'S SUPERVISION AND EMPLOYEES

- A. Contractor shall provide qualified and competent people to administer the contract and perform all the Work.
- B. During performance of the Work the Contractor shall have supervisory personnel on-site and available to administer, manage and coordinate the Work. City shall not be responsible for the acts or omissions of the supervisory personnel or their assistants.
- C. The Contractor shall at all times enforce good order among all persons furnishing labor or materials on-site and shall only employ workers skilled in the work assigned. If requested by the Project Representative, Contractor shall provide the Project Representative with copies of licenses, registrations, and certifications.
 1. City shall have the right to require the Contractor to remove personnel from the Site that do not have the appropriate qualifications and experience to meet or uphold the requirements of the Contract. City shall also have the right to order the Contractor to replace personnel who demonstrate unprofessional behavior.
 2. Failure by City to require removal of any Contractor personnel shall not be deemed an admission that any such personnel are satisfactory, nor shall such failure relieve the Contractor from any contractual responsibility.

3.5 SUBCONTRACTORS AND SUPPLIERS

- A. This Contract is between City and the Contractor.
 1. The Contractor's subcontracting shall not create a contract between City and the Subcontractor and Suppliers. Subcontractors and Suppliers are not intended as incidental third party beneficiaries to the Contract. The Subcontractor and Suppliers shall have no rights against City by reason of their agreements with the Contractor.
 2. The Contractor is responsible for performing all work required by the Contract. The Contract has not been written with the intent of, and City shall not be a party to, defining the division of work between the Contractor and its Subcontractors and Suppliers.
- B. **Selection of Subcontractors and Suppliers**
 1. Subcontractors and Suppliers shall be properly licensed, registered or certified, as applicable, and capable to perform the assigned work.
 2. If requested by City, the Contractor shall provide documentation that the proposed Subcontractors and Suppliers have adequate experience and skill.
 3. The Contractor shall require each Subcontractor and Supplier to comply with all provisions of this Contract. At the request of Subcontractors or Suppliers, Contractor shall make available for copying all Contract Documents.

C. Responsibility for Work of Subcontractors and Suppliers

The Contractor shall be responsible for the acts and omissions of Subcontractors and Suppliers. The Contractor shall also be responsible for the suitability of any materials, components, equipment or supplies furnished by a Subcontractor and/or Supplier irrespective of whether such were designated or approved by City.

3.6 SCHEDULE OF WORKING HOURS

- A. As specified in the Contract, the Contractor shall submit a schedule of working hours, including overtime to City for acceptance. This schedule shall comply with all Contract requirements. Except as permitted elsewhere in the Contract Documents or in the case of an emergency, all Work at the Site shall be performed between the hours of 7am and 6 pm Monday through Friday.
- B. The schedule of working hours accepted by City shall be the only schedule used by the Contractor during performance of the Contract, unless amended to maintain Work progress.
- C. The Contractor shall provide 48 hours advance written Notice of any intent to work outside of approved working hours. Any work at the Site performed outside approved working hours shall be performed without additional expense to City, except as otherwise provided in the Contract Documents. Contractor shall comply with Mercer Island Code Section 8.24.020 (Q) which prohibits construction related noise outside designated hours except in cases of emergency or demonstrated necessity.

3.7 RECORD DOCUMENTS

- A. The Contractor shall maintain an accurate, readable, and orderly set of drawings and specifications, updated as the job progresses to show all approved changes, options, alternates, and all actual deviations from the original Contract Documents. This set of drawings and specifications shall be the Record Documents.
 - 1. The Record Documents shall be maintained in hard copy.
 - 2. In addition to all approved changes, options, alternates, and all actual deviations from the original Contract Documents, the Record Documents shall be marked as follows:
 - a. Record all materials used where options, alternates and/or change orders were indicated, specified and/or authorized;
 - b. Accurate measurements referenced as required by the technical specifications shall be recorded to show the exact location and changes in direction of all underground services and utilities, as well as their depth below finished grade; and
 - c. Record all other requirements as specified in the Technical Specifications.
- B. The Record Documents shall be kept up-to-date and be available for review by City at all times, including but not limited to at each job progress meeting. Failure to have the record set up-to-date shall be sufficient reason for City to withhold payment in accordance with paragraph 7.2, *Payments Withheld*, until all such information is recorded.

- C. Record Documents may be used to assist City to verify the appropriate progress payment.
- D. Neither Final Acceptance nor Final Payment will be issued until a complete set of Record Documents is submitted and the Engineer is satisfied as to its quality and accuracy.

3.8 COST RECORDS

- A. The Contractor, Subcontractors, and Suppliers shall maintain Project cost records by cost codes and shall segregate and separately record at the time incurred all costs (1) directly associated with each work activity and (2) directly or indirectly resulting from any event or condition for which the Contractor seeks an adjustment in the Contract Price, Contract Time, and/or damages.
 - 1. Any costs claimed to result from any such event or condition, including, but not limited to, delay and impact costs, acceleration costs, loss of productivity or efficiency, and increased or extended overhead shall be recorded at the time incurred and be fairly and reasonably allocated to each such event or condition and to other causes of such costs.
 - 2. City shall be provided with a detailed description of all such costs and the basis of allocation. The Contractor, Subcontractors, and Suppliers shall maintain a monthly summary of all costs and shall make all underlying cost records and monthly summary of costs available for review, inspection, and copying by City upon request.
 - 3. Any work performed for which the Contractor intends to seek an adjustment in Contract Price and/or Contract Time shall be recorded on the same day the work is performed and kept separate so as to distinguish it from Contract Work.
- B. In addition to the requirements set forth in Article 5, *Changes to the Contract*, and Article 6, *Time and Price Adjustments*, the Contractor shall be entitled to extra compensation for an event or condition and/or the recovery of damages only to the extent that the Project cost records are kept in full compliance with all Contract requirements and the cost allocations support entitlement to such compensation.

3.9 MAINTENANCE AND INSPECTION OF DOCUMENTS

- A. All Contractor's, Subcontractors', and Suppliers' documents and records relating to the Contract shall be open to inspection, audit, and/or copying by City or its designee:
 - 1. During the Contract Time; and
 - 2. For a period of not less than six years after the date of Final Acceptance of the Contract ("Preservation Period"); or if any Claim, audit or litigation arising out of, in connection with, or related to this Contract is initiated, all documents shall be retained until such Claim, audit or litigation involving the records is resolved or completed, whichever occurs later.
- B. The Contractor shall also guarantee that all Subcontractor and Supplier documents shall be retained and open to similar inspection, audit and/or copying during the Contract Time and also the Preservation Period. The Contractor, Subcontractor, and Supplier shall use its best efforts to cooperate with the inspection, auditing, and/or copying.

- C. Inspection, audit, and/or copying of all documents described herein, may be performed by City or its designee at any time with not less than seven (7) days' Notice. Provided however, if an audit or inspection is to be commenced more than sixty (60) days after the Final Acceptance date of the Contract, the Contractor will be given twenty (20) days' Notice of the date of the audit.
- D. The Contractor, Subcontractors, and Suppliers shall provide adequate facilities, acceptable to City, for inspection, auditing, and/or copying during normal business hours.
- E. If the Contractor is formally dissolved, assigns or otherwise divests itself of its legal capacity under this Contract, then it shall immediately notify City and preserve such records, at its expense, as directed by City.
- F. The Contractor, Subcontractor, and Supplier, shall be subject to audit at any time with respect to this Contract. Failure to maintain and retain sufficient records to allow City to verify all costs or damages or failure to permit City access to the books and records shall constitute a waiver of the rights of the Contractor Subcontractor and Supplier to Claim or be compensated for any damages, additional time or money under this Contract.
- G. At a minimum, the following documents, including the machine readable electronic versions, shall be available for inspection, audits, and/or copying:
 - 1. Daily time sheets and all daily reports, Supervisor's reports, and inspection reports;
 - 2. Collective bargaining agreements;
 - 3. Insurance, welfare, and benefits records;
 - 4. Payroll registers;
 - 5. Earnings records;
 - 6. All tax forms, including payroll taxes;
 - 7. Material invoices and requisitions;
 - 8. Material cost distribution worksheet;
 - 9. Equipment records (list of Contractor's, Subcontractors', and Suppliers' equipment, rates, etc.);
 - 10. Contracts, purchase orders and agreements between the Contractor and each Subcontractor and Supplier;
 - 11. Subcontractors' and Suppliers' payment certificates;
 - 12. Correspondence, including email, with Subcontractors and/or Suppliers;
 - 13. All meeting notes by and between Contractor, Subcontractors, Suppliers and/or any third parties related to the Project;
 - 14. Canceled checks (payroll and vendors);
 - 15. Job cost reports, including monthly totals;
 - 16. Job payroll ledger;
 - 17. Certified payrolls;

18. General ledger;
 19. Cash disbursements journal;
 20. Take off sheets, and calculations used to prepare the bid and/or quotes;
 21. Take off sheets, calculations, quotes, other financial data to support change proposals, request for change order and/or claims;
 22. Financial statements for all years during the Contract Time. In addition, City may require, if it deems appropriate, additional financial statements for 3 years preceding execution of the Contract and 6 years following Final Acceptance of the Contract;
 23. Depreciation records on all Contractor's, Subcontractor's, and Supplier's equipment, whether these records are maintained by the Contractor, Subcontractors, and Suppliers involved, its accountant, or others;
 24. If a source other than depreciation records is used to develop costs for the Contractor's internal purposes in establishing the actual cost of owning and operating equipment, all such other source documents;
 25. All documents which relate to each and every Claim together with all documents which support the amount of damages as to each Claim;
 26. Worksheets or software used to prepare the Claim establishing the cost components for items of the Claim including but not limited to labor, benefits and insurance, materials, equipment, Subcontractors, Suppliers, all documents which establish time periods, individuals involved, the hours for the individuals, and the rates for the individuals;
 27. Worksheets, software, and all other documents used (a) by the Contractor to prepare its bid and schedule(s) and/or (b) to prepare quotes and bids to the Contractor;
 28. All schedule documents, including electronic versions, planned resource codes, or schedules and summaries;
 29. All submittals; and
 30. All other documents, including email, related to the Project, Claims, or Change Orders.
- H. The Contractor shall mark any documentation it considers proprietary or confidential accordingly. Such information will be treated as such by City; however, City cannot ensure that this information will not be subject to release pursuant to a public records request. In the event City receives a request for such information, City will advise the Contractor and will not release the requested information for a period of not less than ten (10) days in order to give the Contractor an opportunity to obtain a court order prohibiting the release of the information in response to the public records request.

3.10 MAINTENANCE AND SITE CLEANUP

- A. The Contractor shall at all times keep the Site, access points, and public rights-of-way free from accumulation of dirt, mud, waste materials or rubbish caused by the Contractor or Subcontractors. At the completion of the Contract Work, the Contractor shall remove and lawfully dispose of all its dirt, mud, waste materials,

rubbish, tools, scaffolding and surplus or partly used materials from the Site and shall leave the Site broom clean unless some stricter standard is specified in the Contract.

- B. The Contractor shall obey all applicable laws and regulations relating to the storage, use, and disposal of Hazardous Materials. The Contractor shall promptly notify City of all Contractor or Subcontractor caused spills or releases of Hazardous Materials, and pay the cost to promptly clean up all such spills or releases and any associated fines or penalties. The Contractor shall maintain documentation of the clean up and disposal all Contractor or Subcontractor caused spills or releases of Hazardous Materials.
- C. If the Contractor fails to adequately maintain or cleanup the Site, City may, after written Notice to the Contractor, sweep surfaces or remove the dirt, mud, waste materials, rubbish, or hazardous materials and charge all reasonable costs of such work to the Contractor.

3.11 PROTECTION OF EXISTING STRUCTURES, EQUIPMENT, VEGETATION, UTILITIES, AND IMPROVEMENTS

- A. Contractor shall protect from damage all existing structures, curbs, gutters, sidewalks, equipment, improvements, utilities, trees, and vegetation not shown in the Contract Documents to be removed or modified at or near the Site. Contractor shall repair, at no cost to City, any such damage resulting from failure to comply with the requirements of the Contract or failure to exercise reasonable care in performing the Work. If Contractor fails or refuses to repair the damage promptly, City may have the necessary work performed and deduct or charge the cost to Contractor or exercise its rights under the Performance and Payment Bond. If there are insufficient funds remaining, excluding retention, the Contractor shall pay City for the costs associated with protection and repairing the damages.

3.12 PERMITS, LAWS, REGULATIONS AND TAXES

- A. Except those permits, easements, and variances specified in the Contract as having been previously obtained by City, all permits, licenses, easements and variances necessary for the execution of the Work shall be secured and paid for by the Contractor. The Contractor shall identify, apply for, and pay for such permits and licenses at the earliest possible time so as to avoid any delay to the Work arising from the permitting and/or licensing process. No actions taken by City to aid the Contractor in securing any permit or license shall relieve the Contractor of any obligations to secure any such permit or license.
- B. The Contractor shall maintain all stamped permit sets of documents at the Site during construction, in good condition and as required by local ordinances.
- C. The Contractor shall perform the Work in full compliance with local, state and federal laws, ordinances, resolutions and regulations, and with permit, license, easement, and variance conditions pertaining to the conduct of the Work. The Contractor shall defend, indemnify, and hold City, its elected officials, officers, agents and employees harmless from any assessment of fines, penalties, or damages arising from violations of the same by the Contractor or Subcontractors. The Contractor shall pay and provide proof of payment for any assessments of fines, penalties or damages. The Contractor shall cooperate with all governmental entities regarding inspection of the Work and compliance with such requirements.

- D. The bid form may include a line item for sales tax on the whole amount, or on items which are not exempt from tax under Washington State Department of Revenue rules, including WAC 458-20-170 and WAC 458-20-171. Unless there are separate line items in the bid form for Washington State sales tax, Contractor shall include all sales tax in its lump sum bid or unit prices. The Contractor should contact the Washington State Department of Revenue for answers to questions in this area. The City will not adjust its payment if the Contractor bases a bid on a misunderstood tax liability. Except as provided above, the Contractor is required to pay all applicable taxes. No adjustment will be made in the amount to be paid by City under the Contract because of any change in law or regulations covering any applicable taxes, or because of any misunderstanding by the Contractor as to its liability for or the amount of any taxes.

3.13 PATENTS AND ROYALTIES

- A. The Contractor shall assume all costs or fees relating to royalties or claims for any patented invention, article, process or method that may be used upon or in a manner connected with the Work under this Contract or with the use of completed Work by City.

3.14 CONTRACTOR'S CERTIFICATION

A. Conflict of Interest

The Contractor certifies (and shall require each Subcontractor to certify) that it has no direct or indirect pecuniary or proprietary interest, and that it shall not acquire any such interest, which conflicts in any manner or degree with the work, services or materials required to be performed and/or provided under this Contract and that it shall not employ any person or agent having any such interest. In the event that the Contractor or its agents, employees or representatives acquires such a conflict of interest, the Contractor shall immediately disclose such interest to City and take action immediately to eliminate the conflict or to withdraw from this Contract, as City may require.

B. Contingent Fees and Gratuities

The Contractor, by entering into this Contract with City to perform or provide work, services or materials, has thereby covenanted:

1. That no person or selling agency except bona fide employees or designated agents or representatives of the Contractor has been or will be employed or retained to solicit or secure this Contract with an agreement or understanding that a commission, percentage, brokerage, or contingent fee may be paid; and
2. That no gratuities, in the form of entertainment, gifts or otherwise, have been or will be offered or given by the Contractor or any of its agents, employees or representatives, to any official member or employee of City or other governmental agency with a view toward securing this Contract or securing favorable treatment with respect to the awarding or amending thereof, or the making of any determination with respect to the performance of this Contract. The Contractor certifies that it has not made any contributions to any person or entity as a condition of doing business with City and it has disclosed to City all attempts by any person to solicit such payments.

3.15 DEVIATION FROM CONTRACT

- A. The Contractor shall not make an alteration, variation, addition, deviation, or omission from the requirements of the Contract Documents without the prior written consent of the Engineer.
- B. Any alteration, variation, addition, deviation, or omission by the Contractor shall not result in any extra compensation or extension of time.

3.16 OPERATIONS, MATERIAL HANDLING, AND STORAGE AREAS

A. Temporary Buildings and Utilities

Temporary buildings (including storage sheds, shops, and offices) and utilities may be erected by Contractor on the Site only with the consent of City and without expense to City. The temporary buildings and utilities shall remain the property of Contractor and shall be removed by the Contractor at its expense upon completion of the Work.

B. Disposal/Removal of Materials

The Contractor shall be responsible for compliance with all laws governing the storage and ultimate disposal of all materials and components. The Contractor shall provide City with a copy of all manifests and receipts evidencing proper disposal when required by City or applicable law.

C. Protection and Care of Contractor's Materials and Equipment

The Contractor shall be responsible for the proper care and protection of its materials and equipment delivered to the Site. Materials and equipment may be stored on the Site at the Contractor's own risk and with prior written approval from City. When the Contractor uses any portion of the Site as a shop, the Contractor shall be responsible for any repairs, patching, or cleaning arising from such use and for obtaining any necessary permits to establish such shop or temporary storage facilities.

3.17 CONTRACTOR'S OVERALL RESPONSIBILITY FOR PROTECTION OF WORK, PROPERTY, AND PERSONS

- A. The Contractor shall be responsible for conditions of the Site, including safety of all persons and property, during performance of the Work. The Contractor shall maintain the Site and perform the Work in a manner which meets all statutory and common law requirements or other specific contractual requirements for the provision of a safe place to work and which adequately protects the safety of all persons and property on or near the Site. This obligation shall apply continuously and shall not be limited to normal working hours. City's inspection of the Work or presence at the Site does not and shall not be construed to include review of the adequacy of the Contractor's safety measures in, on or near the site of the Work.
- B. The Contractor shall be responsible for initiating, maintaining and supervising all safety precautions and programs, including adequate safety training, in connection with the Work. The Contractor shall comply with all applicable laws, ordinances, rules, regulations and lawful orders of any public authority bearing on the safety of persons or property or their protection from damage, injury or loss.
- C. The Contractor shall protect and be responsible for any damage or loss to the Work or to the materials and equipment associated with the Work until the date of

Substantial Completion. The Contractor remains responsible for any damage or loss caused directly or indirectly by the acts or omissions of the Contractor, Subcontractors, Suppliers, or third parties authorized or allowed on the Site by the Contractor until Final Acceptance.

- D. The Contractor shall also be solely and completely responsible for damages arising from the Work that affect property adjacent to the Site.
- E. The Contractor shall repair or replace without cost to City any damage or loss that may occur, except damages or loss caused by the acts or omissions of City.
- F. The Contractor shall erect and maintain adequate steel plates, signs, fencing, barricades, lights or security measures and persons to protect the Work until the Engineer authorizes in writing the removal of signs, fencing, barricades, lights or security measures.
- G. The Contractor shall conduct all operations with the least possible obstruction and inconvenience to the public. To disrupt public traffic as little as possible, the Contractor shall permit traffic to pass through the Project Site with the least possible inconvenience or delay. The Contractor shall maintain existing roads, streets, sidewalks and paths within the Project Site, keeping them open and in good, clean, safe condition at all times.

3.18 PROTECTION OF PERSONS

- A. The Contractor shall take all reasonable precautions for the safety of all employees working on this Contract and all other persons who may be affected by such Work. The Contractor shall designate a responsible member of its organization at the Site whose duty shall be to manage and coordinate the safety programs and to prevent accidents of the Contractor and Subcontractors.
- B. Except as otherwise stated in the Contract, if the Contractor encounters, on the Site, material reasonably believed to be Hazardous Material that Contractor shall immediately stop work in the area affected and give Notice of the condition to City. Work in the affected area shall not be resumed without written direction by City.
- C. To protect the lives and health of persons performing work under this Contract, the Contractor shall comply with the Federal Occupational Safety and Health Act of 1970 (OSHA), including all revisions, amendments and regulations issued thereunder, and the provisions of the Washington Industrial Safety Act of 1973 (WISHA), including all revisions, amendments and regulations issued thereunder by the Washington State Department of Labor and Industries including, without limitation, all excavation, tunneling, trenching and ditching operations. In case of conflict between any such requirements, the more stringent regulation or requirement shall apply. There is no acceptable deviation from these safety requirements, regardless of practice in the construction industry. Any violation of OSHA, WISHA or other safety requirements applicable to the Work may be considered a breach of this Contract.

3.19 SAFETY PROGRAM

The Contractor shall prepare and maintain a written site specific "Safety Program" demonstrating the methods by which all applicable safety requirements of this Contract will be met. The Contractor shall ensure its Subcontractors and Suppliers have a written "Safety Program" or formally adopt the Contractor's site specific "Safety Program." The

Contractor shall conduct a weekly safety meeting with all Subcontractors and others on the Site to discuss general and specific safety matters.

3.20 ARCHAEOLOGICAL AND HISTORICAL PRESERVATION

The Contractor shall comply fully with the requirements set forth in Chapter 27.53 RCW entitled Archaeological Sites and Resources. The Contractor shall immediately notify the City if any artifacts, skeletal remains or other archaeological resources (as defined under RCW 27.53.040 now and as hereinafter amended) are unearthed during excavation or otherwise discovered on the Site.

3.21 WATER POLLUTION CONTROL REQUIREMENTS

The Contractor shall comply with and be liable for all penalties, damages and violations under Chapter 90.48 RCW including any regulations issued pursuant thereto in the performance of the Work.

3.22 EASEMENTS

If the Contractor makes arrangements for use of additional public and/or private property, the Contractor, prior to using such property, shall provide the Engineer with written permission of the landowner, or duly authorized agent of such landowner, for such use.

3.23 TITLE VI / NONDISCRIMINATION ASSURANCES

During the performance of this contract, the contractor/consultant, for itself, its assignees and successors in interest (hereinafter referred to as the "contractor") agrees as follows:

1. Compliance with Regulations

The contractor shall comply with the Regulations relative to non-discrimination in federally assisted programs of United States Department of Transportation (USDOT), Title 49, Code of Federal Regulations, part 21, as they may be amended from time to time, (hereinafter referred to as the Regulations), which are herein incorporated by reference and made a part of this contract.

2. Non-discrimination

The contractor, with regard to the work performed by it during the contract, shall not discriminate on the grounds of race, color, sex, or national origin in the selection and retention of sub-contractors, including procurement of materials and leases of equipment. The contractor shall not participate either directly or indirectly in the discrimination prohibited by Section 21.5 of the Regulations, including employment practices when the contract covers a program set forth in Appendix B of the Regulations.

3. Solicitations for Sub-contracts, Including Procurement of Materials and Equipment

In all solicitations either by competitive bidding or negotiations made by the contractor for work to be performed under a sub-contract, including procurement of materials or leases of equipment, each potential sub-contractor or supplier shall be notified by the contractor of the contractor's obligations under this contract and the Regulations relative to non-discrimination on the grounds of race, color, sex, or national origin.

4. Information and Reports

The contractor shall provide all information and reports required by the Regulations or directives issued pursuant thereto, and shall permit access to its books, records,

accounts, other sources of information, and its facilities as may be determined by the contracting agency or the appropriate federal agency to be pertinent to ascertain compliance with such Regulations, orders and instructions. Where any information required of a contractor is in the exclusive possession of another who fails or refuses to furnish this information, the contractor shall so certify to WSDOT or the USDOT as appropriate, and shall set forth what efforts it has made to obtain the information.

5. Sanctions for Non-compliance

In the event of the contractor's non-compliance with the non-discrimination provisions of this contract, the contracting agency shall impose such contract sanctions as it or the USDOT may determine to be appropriate, including, but not limited to:

- Withholding of payments to the contractor under the contract until the contractor complies, and/or,
- Cancellation, termination, or suspension of the contract, in whole or in part.

6. Incorporation of Provisions

The contractor shall include the provisions of paragraphs (1) through (5) in every sub-contract, including procurement of materials and leases of equipment, unless exempt by the Regulations, or directives issued pursuant thereto. The contractor shall take such action with respect to any sub-contractor or procurement as the contracting agency or USDOT may direct as a means of enforcing such provisions including sanctions for non-compliance.

Provided, however, that in the event a contractor becomes involved in, or is threatened with, litigation with a sub-contractor or supplier as a result of such direction, the contractor may request WSDOT enter into such litigation to protect the interests of the state and, in addition, the contractor may request the USDOT enter into such litigation to protect the interests of the United States.

ARTICLE 4: ADMINISTRATION OF THE CONTRACT

4.1 TIME OF ESSENCE

All time requirements set forth in the Contract Documents are of the essence.

4.2 WORK PROGRESS

A. The Contractor shall be required to:

1. Prosecute the Work diligently with adequate forces;
2. Plan, coordinate, and layout the Work in advance so as to avoid delay; and
3. Achieve Substantial Completion of the Work and Final Acceptance in accordance with the requirements of Contract Documents.

4.3 SCHEDULE OF VALUES

A. Unless otherwise specified, within fourteen (14) days after the date of Contract Execution, the Contractor shall submit to City a detailed Schedule of Values that identifies the various activities of the Work and their values and quantities, including the overhead and profit for each activity. The Contractor warrants that the values identified in its Schedule of Values accurately reflect the value of each work activity. The Schedule of Values shall be used as a basis for calculating all Progress Payments. Payment for Contract Work shall be made only for and in accordance with those activities identified in the Schedule of Values.

- B. The Contractor shall not be entitled to, nor shall City be required to make, payment for any Contract Work until the Schedule of Values has been accepted by City. Such acceptance shall not be unreasonably withheld.
- C. City shall review and accept the Schedule of Values or provide the Contractor with a written explanation of why the Schedule of Values was not acceptable. City shall use reasonable efforts to review the Schedule of Values within thirty (30) days of City's receipt of the Contractor's submittal of its Schedule of Values. City's acceptance of the Schedule of Values shall not relieve the Contractor from its sole responsibility for the accuracy of the Schedule of Values and its compliance with all Contract requirements. The Contractor shall revise the Schedule of Values as necessary to accurately reflect Change Orders.
- D. Each Application for Payment shall include a current status of the Schedule of Values. No Application for Payment will be considered until the current status of the Schedule of Values has been submitted and accepted.
- E. The activities, which the Contractor identifies within its Schedule of Values, shall be specifically referenced within, and conform and be consistent with the activities set forth within the Project Schedule.

4.4 PROJECT SCHEDULE

- A. Unless otherwise specified, within fourteen (14) days after the date of Contract Execution, the Contractor shall submit to City a Project Schedule. The Project Schedule shall show the sequence in which the Contractor proposes to perform the Work, indicate the Critical Path, identify the dates on which the Contractor proposes to start and finish the scheduled activities of the Contract Work, indicate Substantial Completion within the Contract Time, indicate a date for Final Acceptance, and meet all the requirements as may be set forth in the Contract Documents.
- B. Within thirty (30) days of City's receipt of the Contractor's submittal of its Project Schedule or unless stated elsewhere in the Contract, City shall review the Project Schedule and provide the Contractor with written comments. City will review the Project Schedule only to determine whether the Project Schedule meets the requirements in the Technical Specifications on Project Schedule. To the extent the Project Schedule does not meet such Technical Specifications, the Contractor shall revise the Project Schedule to make it compliant.
- C. By reviewing the Project Schedule and providing written comments, City is not approving or adopting the Contractor's plan, schedule, means, methods, techniques, sequences, or procedures required to perform the Work. Review and comment by City of the Project Schedule shall not relieve the Contractor from the sole responsibility for the accuracy of a Project Schedule, and its compliance with all Contract requirements, and its responsibility to meet all required Contract completion dates. Failure by City to indicate items on the Project Schedule that do not conform with the Contract requirements shall not alter or waive the Contract requirements or relieve the Contractor from complying with all Contract requirements.
- D. The Contractor shall not be entitled to, nor shall City be required to make payment for any Contract Work until the Project Schedule complies with all Contract requirements.
- E. The Contractor shall schedule the Contract Work so that the Contract Work is completed within the Contract Time. Float in the project Schedule shall be defined as the period of time measured by the number of days each non-critical path

activity may be delayed before it and its succeeding activities become part of the Critical Path. Contractor and Owner may both utilize float to offset delays to the Work.

- F. The Contractor shall regularly enter the actual progress of the Work and Contract Time extensions, if any, approved by City on the Project Schedule. Updated Project Schedules shall reflect actual progress and completion within the Contract Time and shall be provided to City with each Application for Payment in format(s) as required by the Contract. Applications for Progress Payments will not be considered by City and the Contractor will not be paid until the Contractor complies with these requirements. The updated Project Schedule shall be used to assist City in verifying the appropriate payment.
- G. If, in the opinion of City, the Contractor falls behind in its progress of the Work due to acts or omissions of the Contractor, Subcontractors, and Suppliers, the Contractor shall take all necessary steps to improve its progress and bring its progress back in-line with the accepted Project Schedule, without additional cost to City. In this circumstance the Contractor shall, as necessary, increase the number of shifts, overtime operations, and/or days of work, both on and off the Site, and submit for acceptance any supplementary schedule or schedules as City deems necessary to demonstrate how the accepted rate of progress will be regained. Failure of the Contractor to comply with the requirements under these provisions shall be grounds for a determination by City that the Contractor is not prosecuting the Work with sufficient diligence to ensure completion within the time specified in the Contract. Upon making this determination, City may pursue any right it has under the law or the Contract, including but not limited to default termination.

4.5 SUBMITTALS

- A. Submittals include shop drawings, setting and erection drawings, schedules of materials, product data, samples, certificates and other information prepared for the Work by the Contractor or a Subcontractor as set forth in the Technical Specifications ("Submittals"). The Contractor shall perform no portion of the Work requiring Submittals until the Submittals have been reviewed and returned by City with one of the following annotations: (1) no exceptions taken, or (2) note markings.
- B. When submitting information, the Contractor shall identify and state reasons for any alteration, variation, addition, deviation, or omission from the Contract. The Contractor shall not perform work that alters, varies, adds to, deviates from, or omits any requirement of the Contract Documents without prior specific written acceptance by City.
- C. The Contractor shall provide Submittals with reasonable promptness and in such sequence as to facilitate the timely completion of the Contract.
- D. City shall review the Contractor's Submittals and respond in writing with reasonable promptness so as not to unreasonably delay the progress of the Work. Unless otherwise agreed, no delay to the Work shall be attributable to the failure by City to respond to a Submittal until thirty (30) days after the Submittal is received by City, and then only if failure by City to respond is unreasonable and affects the Contract completion date.
- E. If the Contractor is required to resubmit a Submittal, any revisions on resubmittals shall be specifically identified in writing and the resubmitted Submittal shall be sequentially alpha denoted (for example: 22A followed by 22B, etc.) and note revisions in numerical order. The cost of the review of the initial Submittal and the first revised submittal shall be borne by City. The costs of all

additional revised Submittals shall be charged to the Contractor. The cost of review shall include, without limitation, administrative, design, and engineering activities directly related to review of Submittals. City may deduct these costs from any amounts due the Contractor.

- F. City shall review the Contractor's Submittals only for conformance with the design of the Work and compliance with the Contract. Review of the Submittals are not conducted to verify the accuracy of dimensions, quantities, or calculations, the performance of materials, systems, or equipment, or construction means, methods, techniques, sequences, or procedures, all of which remain the Contractor's responsibility. Failure by City to take exception to a Submittal shall not relieve the Contractor from any duty, including its responsibility for errors or omissions in Submittals, its duty to make Submittals and duty to perform the Work according to the requirements of the Contract. City's review of a Submittal shall not alter or waive the requirements of the Contract unless City has issued prior written approval of such change or alteration of the Contract requirements.
- G. The Contractor's failure to identify any error, deviation, or omission and subsequent acceptance of the Submittal by City shall not relieve the Contractor from complying with the Contract requirements.

4.6 REQUESTS FOR INFORMATION

- A. If the Contractor determines that some portion of the drawings, specifications or other Contract Documents require clarification or interpretation by City because of an apparent error, inconsistency, omission, or lack of clarity in the Contract, the Contractor shall promptly submit a Request For Information ("RFI") and, unless otherwise directed, shall not proceed with the affected work until City has responded to the RFI. The Contractor shall plan its work in an efficient manner so as to allow for timely responses to RFIs.
- B. City shall respond in writing with reasonable promptness to Contractor's RFI.
 - 1. At the request of the Engineer, the Contractor shall prioritize its RFIs, identify a date by which the Contractor prefers the RFI be answered, and reasons for such priority.
 - 2. If the Contractor submits a RFI on an activity less than thirty (30) days prior to the commencement of that activity, the Contractor shall not be entitled to any time extension or adjustment in Contract Price due to the time it takes City to respond to the RFI provided that City responds within fifteen (15) days. No delay to the Work or damages to the Contractor shall be attributable to the failure by City to respond to the RFI until fifteen (15) days after City's receipt of the RFI, and then only if the failure by City to respond is unreasonable and affects the Contract completion date.
- C. City's response to a RFI shall not be considered a change to the Contract requirements unless it is accompanied by a Request for Change Proposal. If the Contractor believes that City's response to the RFI constitutes changed work impacting Contract Price or Contract Time, the Contractor shall submit a Notice of Claim, Supplemental Information and a Request for Change Order to City in accordance with Articles 5, *Changes to the Contract*.

4.7 TESTS, INSPECTIONS, AND ACCESS TO THE WORK

- A. Contractor shall be responsible for inspection and quality assurance of all the Work including all work performed by any Subcontractor. The Contractor shall document and maintain an adequate testing and inspection program and perform such tests and inspections as are necessary or required to ensure that the Work conforms to the requirements of the Contract. The Contractor shall maintain all documentation related to testing and inspection and make such documentation available to City at its request. Unless otherwise provided, Contractor shall make arrangements for such tests, inspections, and approvals with an independent testing laboratory or entity acceptable to City, or with the appropriate public authority. If any governmental, regulatory, or permitting authority requires any portion of the Work to be inspected, tested, or approved, the Contractor shall make all arrangements for and cooperate with such inspections, tests, and approvals so as not to delay completion of the Work. The Contractor shall bear all related costs of tests, inspections, and approvals. The Contractor shall give City at least three (3) days' Notice of: (1) when the work is ready to be tested and inspected and (2) when and where tests and inspections are to be made. Contractor shall maintain complete inspection records and make them available to City upon request.
- B. The Contractor shall cooperate with City in the performance of any tests and inspections of the Work. The Contractor has the duty to coordinate all tests and inspections in a manner, which does not negatively impact Contractor's compliance with the Contract.
- C. If any Work required to be inspected, tested, or approved is covered without such inspection, testing or approval being obtained, it must, if requested by City, be uncovered for observation, and such uncovering shall be at Contractor's expense.
- D. City may, at any reasonable time and at its own cost, conduct inspections and tests as it deems necessary to ensure that the Work is in accordance with the Contract. City shall promptly notify Contractor if an inspection or test reveals that the Work is not in accordance with the Contract. City inspection and tests are for the sole benefit of City and do not:
 - 1. Constitute or imply acceptance;
 - 2. Relieve Contractor of responsibility for providing adequate quality control measures;
 - 3. Relieve Contractor of responsibility for risk of loss or damage to the Work, materials, or equipment;
 - 4. Relieve Contractor of its responsibility to comply with the requirements of the Contract; or
 - 5. Impair City's right to reject defective or nonconforming items, or to avail itself of any other remedy to which it may be entitled.
- E. Neither observations by an inspector retained by City, the presence or absence of such inspector on the Site, nor inspections, tests, or approvals by others, shall relieve Contractor from any requirement of the Contract. Inspectors are not authorized to change any term or condition of the Contract.
- F. Contractor shall promptly furnish, without additional charge, all facilities, labor, material and equipment reasonably needed for performing such safe and convenient inspections and tests as may be required by City. City may charge

Contractor any additional cost of inspection or testing when Work is not ready at the time specified by Contractor for inspection or testing, or when prior rejection makes reinspection or retest necessary. City shall perform its inspections and tests in a manner that will cause no undue delay in the Work.

4.8 CORRECTION OF WORK OR DAMAGED PROPERTY

- A. If material, equipment, workmanship, or work proposed for, or incorporated into the Work, does not meet the Contract requirements or fails to perform satisfactorily, City shall have the right to reject such work by giving the Contractor written notice and may require the Contractor to promptly repair, replace or correct it at no cost to the City.
- B. If the Contractor does not repair, replace or correct and/or remove defective or non-conforming Work or repair damaged property as required by City, in manner and/or schedule, City or City's designee may repair, replace or correct and/or remove it and deduct the cost of such effort from any payment due the Contractor.
 - 1. If the remaining payments due the Contractor are not sufficient to cover City's cost of remedying the defective or non-conforming Work, the Contractor shall pay the difference to City.
- C. The Contractor shall be liable for all damages and costs incurred by City caused by defective or non-conforming work or workmanship, including but not limited to all special, incidental, or consequential damages incurred by City.

4.9 SUBSTITUTION OF PRODUCTS & PROCESSES

- A. Substitutions requested by the Contractor will be subject to City's prior written acceptance and at City's sole discretion.
- B. Requests for substitution must specifically identify:
 - 1. Material, equipment, and labor costs included in the Contractor's bid associated with the original item to be substituted;
 - 2. All costs for material, equipment, labor associated with the proposed substitution, including any impact costs;
 - 3. Proposed change to the Contract Price and/or Contract Time; and
 - 4. Compatibility with or modification to other systems, parts, equipment or components of the Project and Contract Work.
- C. Contractor shall provide all documentation supporting its request as requested by City.
- D. All costs of any redesign or modification to other systems, parts, equipment or components of the Project or Contract Work, which result from the substitution, shall be borne by the Contractor.
- E. When City approves a substitution proposed by the Contractor, the Contractor shall guarantee the substituted article or materials to be equal to, or better than, those originally specified and shall be compatible with all other systems, parts, equipment or components of the Project and Contract Work. City has the right to order an unaccepted, substituted article removed and replaced without additional cost to City.

- F. City has a right to a deductive Change Order if the substituted product or process is less costly than the contractually required product or process.
- G. If City does not accept the substitution proposal the Contractor shall proceed, without delay or cost to City, with the Contract Work as originally specified.

4.10 INCREASED OR DECREASED QUANTITIES

- A. Payment to the Contractor will be made only for the actual quantities of work performed and accepted in conformance with the contract. When the accepted quantity of work performed under a unit item varies from the original proposal quantity, payment will be at the unit contract price for all work unless the total accepted quantity of any contract item, adjusted to exclude added or deleted amounts included in change orders accepted by both parties, increases or decreases by more than 25 percent from the original proposal quantity. In that case, payment for contract work may be adjusted as described herein:
 - 1. The adjusted final quantity shall be determined by starting with the final accepted quantity measured after all work under an item has been completed. From this amount, subtract any quantities included in additive change orders accepted by both parties. Then, to the resulting amount, add any quantities included in deductive change orders accepted by both parties. The final result of this calculation shall become the adjusted final quantity and the basis for comparison to the original proposal quantity.
 - a. Increased Quantities: Either party to the contract will be entitled to renegotiate the price for that portion of the adjusted final quantity in excess of 1.25 times the original proposal quantity. The price for excessive quantities will be determined by agreement of the parties, or, where the parties cannot agree, the price will be determined by the City based upon the actual costs to perform the work, including markup for overhead and profit in accordance with Paragraph 6.3, *Allowable Costs*.
 - b. Decreased Quantities: Either party to the contract will be entitled to an equitable adjustment if the adjusted final quantity of work performed is less than 75 percent of the original bid quantity. The equitable adjustment shall be based upon and limited to three factors:
 - i. Any increase or decrease in unit costs of labor, materials or equipment, utilized for work actually performed, resulting solely from the reduction in quantity;
 - ii. Changes in production rates or methods of performing work actually done to the extent that the nature of the work actually performed differs from the nature of the work included in the original plan; and
 - iii. An adjustment for the anticipated contribution to unavoidable fixed cost and overhead from the units representing the difference between the adjusted final quantity and 75% of the original plan quantity.
- B. The following limitations shall apply to renegotiated prices for increases and/or equitable adjustments for decreases:
 - 1. Labor, materials and equipment rates shall be actual costs but shall not exceed the rates set forth in Paragraph 6.3, *Allowable Costs* nor shall overhead and profit exceed the rates set forth in Paragraph 6.3, *Allowable Costs*.

2. No payment for consequential damages or loss of anticipated profits will be allowed because of any variance in quantities from those originally shown in the proposal form, contract provisions, and contract plans.
 3. The total payment (including the adjustment amount and unit prices for work performed) for any item which experiences an equitable adjustment for decreased quantity shall not exceed 75% of the amount original bid for the item.
- C. If the adjusted final quantity of any item does not vary from the quantity shown in the proposal by more than 25% then the Contractor and the City agree that all work under that item will be performed at the original contract unit price and within the original time for completion.
 - D. When ordered by the Engineer, the Contractor shall proceed with the work pending determination of the cost or time adjustment for the variation in quantities.
 - E. The Contractor and the City agree that there will be no cost adjustment for decreases if the City has entered the amount for the item in the proposal form only to provide a common proposal for bidders.

ARTICLE 5: CHANGES TO THE CONTRACT

5.1 GENERAL

- A. No provisions of the Contract may be amended or modified except by written agreement signed by the City.
- B. All Change Order work shall be performed in accordance with the original Contract requirements unless modified in writing by City.
- C. Any response to a Request For Information, or other directive, direction, instruction, interpretation, or determination (hereinafter referred to as "Direction" for the purposes of Article 5), provided by City is not considered a Change Order, a change to Contract requirements, and shall not constitute, in and of itself, entitlement to an adjustment in Contract Price and/or Contract Time.
- D. The Contractor shall not be entitled to any change in the Contract Price and/or Contract Time under the following conditions or events:
 1. They were reasonably foreseeable at the time the Contractor submitted its bid;
 2. They were caused by the acts of the Contractor, Subcontractor and/or Supplier, including but not limited to the choice of means, methods, techniques, sequences, or procedures for the Work, failure to provide labor, materials or equipment in a timely manner, and failure to take reasonable steps to mitigate delays, disruptions, or conditions encountered.
- E. The Contract requirements for time and price impacts related to Change Orders are set forth in Article 6, *Time and Price Adjustments*.
- F. If there is a bid item for "Minor Changes," payments or credits for changes that cost \$5,000 or less and do not affect time, may, at the discretion of the City, be made under that bid item in lieu of the procedures set forth in Sections 5.1 – 5.6. A Minor Change will be documented by a written Order for a Minor Change or by a notation confirming an oral agreement.

5.2 CONTRACTOR'S REQUEST FOR A CHANGE ORDER

- A. Notice of Claim and Supplemental Information. If the Contractor believes that it is entitled to additional compensation and/or time for any reason (other than for a differing site condition under Section 5.2), or if the Contractor disagrees with any written or oral direction, instruction, interpretation or determination from the City, the Contractor shall
- (1) Provide the Engineer with a written Notice of Protest before doing any work or incurring any costs for which it may seek additional compensation or time from the City.
 - (2) Supplement the written Notice of Protest within 14 days with a written statement that includes the following:
 - a. The date, circumstances, and basis of entitlement to additional compensation and/or time;
 - b. The estimated dollar cost of the protested work and a detailed breakdown showing how that estimate was determined;
 - c. An analysis of the progress schedule showing the schedule change or disruption if the Contractor is asserting a schedule change or disruption;
 - d. Substantive basis of the Request;
 - e. If the protest is continuing, the information required above shall be supplemented upon request by the Engineer until the protest is resolved; and
 - f. The Contractor waives all claims for additional compensation and time if it fails to provide both a timely Notice of Claim and Supplemental Information with the information required by this Section.
- B. Request for Change Order.
1. A Request for a Change Order must be submitted in writing to the Engineer no later than thirty-five (35) days after the Contractor submitted its supplemental information pursuant to Paragraph 5.1(A)(2).
 2. The Request for a Change Order shall include:
 - a. Specific dollar amount covering all costs associated calculated in accordance with Article 6, *Time and Price Adjustments*;
 - b. Specific request for time extension (number of days) calculated in accordance with Article 6, *Time and Price Adjustments*;
 - c. A copy of the written Notice of intent, including all attachments;
 - d. All documentation supporting the Request for a Change Order, including but not limited to a cost proposal prepared using the forms provided by City, all cost records, schedule analysis, and the documents identified in §00700, ¶13.10, *Maintenance and Inspection of Documents*, that are in any way relevant to the Contractor's Request for Change Order; and
 - e. The Contractor waives all claims for additional compensation and time if it fails to provide a timely Request for Change Order with the information required by this Section.
- C. City's Response to Contractor's Request for Change Order.

1. City will make a written determination with respect to the Contractor's Request for Change Order within thirty (30) days of receipt of said Request, unless one of the following activities occurs.
 - a. City may request additional information and specify a time period for receipt of the information. The Contractor shall comply with City's request for additional information.
 - b. City may inform the Contractor that additional time is needed to review the Contractor's Request for Change Order and identify a date certain when a decision will be rendered.
 2. If City requests additional information, City will make a written determination within thirty (30) days receipt of Contractor's additional information.
 3. If City does not make a determination within the applicable time period, the Request For Change Order is deemed denied.
- D. Approval of Request for Change Order and Execution of Change Order. If City determines that a Change Order is necessary, the parties may negotiate acceptable terms and conditions and execute a Bilateral Change Order or City may issue a Unilateral Change Order.
- E. Contractor Procedure upon Denial or Deemed Denial of a Request for a Change Order. If the Contractor disagrees with the denial, the Contractor's sole remedy shall be to file a fully documented Claim within thirty (30) days of deemed denial or the Contractor's receipt of the denial in accordance with Article 9, *Claims and Litigation*.
- F. Contractor's Obligation to Continue to Work. Pending resolution of the Contractor's Request for a Change Order, the Contractor shall continue to perform all Work including, at the written request of City that work associated with the pending Request for Change Order. The Contractor shall maintain its progress with the Work.
- G. Waiver. Failure to follow the provisions set forth herein shall constitute a waiver of the Contractor's right to receive any additional time or money as a result of any alleged direction, instruction, interpretation, determination by City and/or the event or impact to the Project.

5.3 DIFFERING SITE CONDITIONS

- A. Immediate Written Notice to City. If the Contractor encounters a Differing Site Condition as defined in Article 1.0 the Contractor shall immediately, and before the conditions are disturbed, give written Notice to City of Differing Site Conditions.
- B. Request for Change Order based on Differing Site Condition. Unless otherwise agreed upon in writing by the Engineer, within forty-five (45) days of the Contractor's initial written notification of the Differing Site Condition to City, the Contractor shall provide a Request for Change Order that includes all elements required for such a request, including:
 1. A detailed description of the Differing Site Condition; and
 2. Substantive, contractual, and technical basis supporting the existence of the Differing Site Condition and its impacts.
- C. Waiver.

1. If the Contractor's actions disturb the Site such that City or City's designee cannot adequately and fully investigate the alleged differing site condition, the Contractor waives its right to receive any additional time or money as a result of the Differing Site Condition.
 2. Failure by the Contractor to provide either (a) immediate Notice or (b) Request for Change Order shall constitute a waiver of the Contractor's right to receive any additional time or money as a result of the Differing Site Condition.
 3. The Contractor shall be responsible for any and all costs or damages incurred by City resulting from the Contractor's failure to provide appropriate notice and/or the Detailed Description and Request for Change Order.
- D. City's Response to the Differing Site Condition Request for Change Order. City shall investigate the alleged Differing Site Conditions and respond to the Differing Site Condition in accordance with the Request for Change Order procedures set forth above.
- E. Contractor's Obligation to Continue to Work. The Contractor shall not disturb the condition until receipt of written authorization from the Engineer that work can resume at the location of the alleged Differing Site Condition. The Contractor shall continue with performance of all other Work.

5.4 SUSPENSION OF WORK

A. City Issues Directive Suspending Work

1. City may order the Contractor, in writing, to suspend all or any part of the Work of this Contract for the period of time that City determines appropriate for the convenience of City. The Contractor shall not suspend the Work without written direction from City specifically authorizing the Suspension of Work.
2. Upon receipt of a written Notice suspending the Work, the Contractor shall immediately comply with its terms and take all reasonable steps to minimize costs attributable to such suspension. Within a period up to 120 days after the suspension notice is received by the Contractor, or within any extension of that period which City requires, City shall either:
 - a. Cancel the written notice suspending the Work; or
 - b. Terminate the Work for either default or convenience.
3. If a written notice suspending the Work is canceled or the period of the Suspension or any extension thereof expires, the Contractor shall resume Work as required by City.
4. If the performance of all or any part of the Work is, for an unreasonable period of time, suspended by the written direction of City, the Contractor may be entitled to an adjustment in the Contract Time, or Contract Price, or both, for increases in the time or cost of performance directly attributable to the suspension and provided that the Contractor sufficiently documents all costs and time impacts attributable to the suspension. No adjustments to Contract Price and/or Contract Time shall be allowed unless the Contractor can demonstrate that the period of suspension caused by City impacted Critical Path and delayed the Contractor from completing the Work on time.

B. Constructive Suspension of Work

1. If the Contractor believes that some action or omission on the part of City constitutes constructive suspension of Work, the Contractor shall immediately notify City in writing that the Contractor considers the actions or omission a constructive suspension of Work.
- C. To the extent the Contractor believes it is entitled to any additional money or time as a result of the suspension of Work or constructive suspension, Contractor shall submit a Notice of Protest, Supplemental Information and Request for Change Order to City in accordance with Article 5, *Changes to the Contract*.
- D. Failure to comply with these requirements shall constitute a waiver of Contractor rights to any adjustment in Contract Time and/or Contract Price.
- E. No adjustment shall be made under this provision for any suspension to the extent that Contractor's performance would have been suspended, delayed, or interrupted as a result of actions, omissions, fault or negligence caused, in whole or in part, by the Contractor or any of its Subcontractors.

5.5 FORCE MAJEURE

- A. To the extent the Contractor believes it is entitled to any additional time as a result of Force Majeure, Contractor shall submit a Notice of Protest, Supplemental Information and Request for Change Order to City in accordance with Article 5, *Changes to the Contract*.
- B. Contractor shall not be entitled to a change in Contract Price resulting from an act of Force Majeure.
- C. Contractor is not entitled to an adjustment in Contract Time if the act of Force Majeure did not impact progress of the Work on the Critical Path and delay the Contractor from completing the Work within the Contract Time.
- D. When a Contractor experiences concurrent delay caused by either City or Contractor and an act of Force Majeure, the Contractor shall only be entitled to an change in Contract Time. No change to the Contract Price shall be allowed as a result of such concurrent delay.

5.6 CHANGE ORDERS

A. Bilateral Change Orders

1. If City and Contractor reach agreement on the terms and conditions of any change in the Work, including any adjustment in the Contract Price and Contract Time, such agreement shall be incorporated into a Change Order and signed by both Parties. Such Bilateral Change Orders shall represent full and complete payment and final settlement of all changes, Claims, damages or costs for all (a) time; (b) direct, indirect, and overhead costs; (c) profit; and (d) any and all costs or damages associated with delay, inconvenience, disruption of schedule, impact, ripple effect, loss of efficiency or productivity, acceleration of work, lost profits, stand-by, and any other costs or damages related to any work either covered or affected by the Change Order, or related to the events giving rise to the Bilateral Change Order.

B. Unilateral Change Order

1. City's Right to Issue Unilateral Change Order.

- a. City may unilaterally issue a Change Order at any time, without invalidating the Contract and without notice to the sureties, making changes within the general scope of this Contract.
- b. If any such Change Order causes an increase or decrease in the cost of, or time required for, performance of any part of the Work, City may make an adjustment in the Contract Price, Contract Time, or both, in accordance with Articles 5, *Changes to the Contract*, and 6, *Time and Price Adjustments*.

2. Contractor Disagreement with Unilateral Change Order. If the Contractor disagrees with the adjustment to the Contract Price and/or Time as indicated in the Unilateral Change Order, the Contractor must submit a Notice of Protest, Supplemental Information and Request for Change Order to City in accordance with Article 5, *Changes to the Contract*.

3. Contractor's Obligation to Continue to Work. The Contractor is required to continue with performance of all Work, including work associated with the Unilateral Change Order.

5.7 CITY REQUEST FOR A CHANGE PROPOSAL

A. Request. City may request a written Change Proposal from the Contractor for a change in the Work.

B. Contractor's Proposal. Contractor shall submit its written Change Proposal within the time specified in City's request with the costs shown in a form acceptable to the City. The Change Proposal shall represent the Contractor's offer to perform the requested work, and the pricing set forth within the proposal shall represent full, complete, and final compensation for the proposed change and any impacts to any other Work, including any adjustments in the Contract Time.

C. City's Acceptance of Contractor Proposal. If City accepts the Change Proposal as submitted by the Contractor or as negotiated by the parties, City shall notify the Contractor in writing of its acceptance of the Proposal and direct that the change in the Work be performed.

D. Execution of a Bilateral Change Order. After acceptance of the Change Proposal or acceptance of the negotiated Change Proposal, City shall direct the Contractor to perform the work in accordance with the agreed upon terms; thereafter, the Parties shall execute a bilateral Change Order in accordance with the terms of the Change Proposal or negotiated Change Proposal.

E. Execution of Unilateral Change Order. If City does not accept the Change Proposal or the Parties cannot agree upon the appropriate price or terms for the Change Proposal, City may issue a unilateral Change Order.

ARTICLE 6: TIME AND PRICE ADJUSTMENTS

6.1 CHANGE IN THE CONTRACT TIME

A. The Contract Time shall only be changed by a Change Order.

- B. No change in the Contract Time shall be allowed to the extent the time of performance is changed due to the fault, act, or omission of Contractor, or anyone for whose acts or omissions the Contractor is responsible.
- C. Contractor is not entitled to a change in Contract Time unless the progress of the Work on the Critical Path is delayed and completion of the Contract Work within Contract Time is delayed.
- D. When a Contractor experiences concurrent delays which impact the Critical Path and are caused by (1) City and the Contractor; (2) City and an act of Force Majeure; or, (3) the Contractor and an act of Force Majeure, the Contractor shall only be entitled to a change in Contract Time. No change to the Contract Price shall be allowed as a result of such concurrent delay.
- E. A Request for Change Order that includes a request for an adjustment in the Contract Time shall:
 - 1. Be in writing and delivered to City within the appropriate time period specified in Article 5, *Changes in the Contract*.
 - 2. Include a clear explanation of how the event or conditions specifically impacted the Critical Path and overall Project Schedule and the amount of the adjustment in Contract Time requested.
 - 3. Be limited to the change in the Critical Path of a Contractor's Project Schedule, and any updates, attributable to the event or conditions, which caused the request for adjustment. No extension of time or compensation for damages resulting from delay will be granted unless the delay affects the timely completion of all Work under the Contract or timely completion of a portion of the Work for which time of completion is specific. Contractor shall be responsible for showing clearly on the Project Schedule, and any updates, that the event or conditions:
 - a. Had a specific impact on the Critical Path and was the sole cause of such impact;
 - b. Could not have been avoided by resequencing of the Work or other reasonable alternatives; and
 - c. Will prevent the Contractor from completing the Project within the current Contract completion date.
- F. Contractor shall make all reasonable efforts to prevent and mitigate the effects of any delay, whether occasioned by an act of Force Majeure or otherwise.

6.2 CHANGE IN THE CONTRACT PRICE

- A. The Contract Price shall only be changed by a Change Order.
- B. No change in the Contract Price shall be allowed when:
 - 1. Contractor's changed cost of performance is due to the fault, acts, or omissions of Contractor, or anyone for whose acts or omissions Contractor is responsible, including its subcontractors and suppliers;
 - 2. The change is concurrently caused by Contractor and City; or
 - 3. The change is caused by an act of a third party or Force Majeure.

- C. City shall not be responsible for, and the Contractor shall not be entitled to any compensation for unallowable costs. Unallowable costs include, but are not limited to:
1. Interest or attorney's fees of any type other than those mandated by Washington state statute;
 2. Claim preparation or filing costs;
 3. The cost of preparing or reviewing Change Proposals or Requests for Change Orders;
 4. Lost profits, lost income or earnings;
 5. Costs for idle equipment when such equipment is not at the Site, has not been employed in the Work, or is not scheduled to be used at the Site;
 6. Lost earnings or interest on unpaid retainage;
 7. Claims consulting costs;
 8. The costs of corporate officers or staff visiting the Site or participating in meetings with City;
 9. Loss of other business; and/or
 10. Any other special, consequential, or incidental damages incurred by the Contractor, Subcontractor, or Suppliers.
- D. A Request for Change Order that includes a request for an adjustment in Contract Price shall:
1. Be in writing and delivered to City within the applicable time period specified in Article 5, *Changes to the Contract*.
 2. Identify the following information:
 - a. The event or condition which caused the Contractor to submit its request for an adjustment in the Contract Price;
 - b. The nature of the impacts to Contractor and its Subcontractors, if any; and
 - c. The amount of the adjustment in Contract Price requested calculated in accordance with Paragraph 6.3, *Allowable Costs*, and using forms provided by City.
 3. Any requests by Contractor for an adjustment in the Contract Price and in the Contract Time that arise out of the same event or conditions shall be submitted together.
- E. The adjustments to the Contract Price provided for in this Article represent full, final, and complete compensation for all work done in connection with the request for an adjustment in Contract Price and all costs related to, resulting from, or affected by such change in Work including, but not limited to, all direct and indirect costs, overhead, profit, and all costs or damages associated with delay, inconvenience, disruption of schedule, impact, dilution of supervision, inefficiency, ripple effect, loss of efficiency or productivity, acceleration of work, lost profits, and any other costs or damages related to any work either covered or affected by the change in the Work, or related to the events giving rise to the change.

6.3 METHOD TO CALCULATE ADJUSTMENTS TO CONTRACT PRICE

- A. One of the following methods shall be used to calculate damages and/or adjustments to the Contract Price that result from or relate to Change Proposal, Request for Change Order, and/or Claim.
- B. Determination of the method to be used to calculate adjustments in the Contract Price shall be at the sole discretion of City.
- C. One of the following methods shall be used:
 - 1. Unit Price Method;
 - 2. Firm Fixed Price Method (also known as Lump Sum); or
 - 3. Time and Materials Method.
- D. **Unit Price Method**
 - 1. The City may direct the Contractor to perform extra work on a Unit Price basis. Such authorization shall clearly state the:
 - a. Scope of work to be performed;
 - b. Applicable Unit Price; and
 - c. Not to exceed amount of reimbursement as established by City.
 - 2. The applicable unit price shall include reimbursement for all direct and indirect costs of the work, including Overhead and profit, as limited by paragraph 6.3, *Allowable Costs*.
 - 3. Contractor shall only be paid under this method for the actual quantity of materials incorporated in or removed from the Work and such quantities must be supported by field measurement statements verified by City.
- E. **Firm Fixed Price Method**
 - 1. The Contractor and City may mutually agree on a fixed amount as the total compensation for the performance of changed work.
 - 2. The Contractor shall provide a detailed cost breakdown supporting the Contractor's requested adjustment to Contract Price and any other financial documentation requested by the Engineer, as limited by paragraph 6.3, *Allowable Costs*.
 - 3. Any adjustments to the Contract Price using the Firm Fixed Price Method shall include, when appropriate all reasonable costs for labor, equipment, material, Overhead and profit. Such labor, equipment, material, Overhead and profit shall be calculated in accordance with paragraph 6.3, *Allowable Costs*.
 - 4. Whenever City authorizes Contractor to perform changed work on a Firm Fixed Price Method, City's authorization shall clearly state:
 - a. Scope of work to be performed; and
 - b. Total Fixed Price payment for performing such work.
- F. **Time and Materials Method**
 - 1. Whenever City authorizes the Contractor to perform work on a Time and Material basis, City's authorization shall clearly state:

- a. Scope of work to be performed; and
 - b. A not to exceed amount of reimbursement as established by City.
2. Contractor shall:
- a. Cooperate with City and assist in monitoring the work being performed;
 - b. Substantiate the labor hours, materials and equipment charged to work under the Time and Materials Method by detailed time cards or logs completed on a daily basis before the close of business each working day;
 - c. Present the time card and/or log at the close of business each day to the Engineer so that City may review and initial each time card/log;
 - d. Perform all work in accordance with this provision as efficiently as possible;
 - e. Not exceed any cost limit(s) without City's prior written approval; and
 - f. Maintain all records of the work, including all records of the Subcontractor, Supplier, and Materialmen, and make such records available for inspection as required in paragraphs 3.8, *Record Documents*, 3.9, *Cost Records*, and 3.10, *Maintenance and Inspection of Document*.
3. Contractor shall submit costs and any additional information requested by City to support Contractor's requested price adjustment.
4. The Contractor shall only be entitled to be paid for reasonable costs actually incurred by the Contractor. The Contractor has a duty to control costs. If City determines that the Contractor's costs are excessive or unreasonable, City, at its discretion, shall determine the reasonable amount for payment.

G. Deductive Changes to the Contract Price

1. A deductive change to the Contract Price may be determined by taking into account:
- a. Costs incurred and saved by the Contractor as a result of the change, if any;
 - b. The costs of labor, material, equipment, and overhead saved and profit unearned by the deleted work. These costs shall be calculated following as closely as possible with the provisions identified in Article 6, Time and Price Adjustments; and/or,
 - c. At the discretion of City, costs set forth in the documents used by the Contractor to develop its bid.
2. Where City has elected not to correct incomplete or defective Work, the adjustment in the Contract Price shall take into account:
- a. The costs the City would have to expend to correct the Work;
 - b. The decreased value to City resulting from the incomplete or defective Work; and,
 - c. The increased future costs which City may incur by reason of the incomplete or defective Work.

H. Full Compensation

An adjustment calculated in accordance with the provisions of this Article shall be full and complete payment and final settlement of all changes, claims, damages and costs for all (a) time; (b) direct, indirect, and overhead costs; (c) profit; and (d) any and all costs or damages associated with delay, inconvenience, disruption of schedule, impact, ripple effect, loss of efficiency or productivity, acceleration of work, lost profits, standby, and/or any other costs or damages related to any Work either covered or affected by the changed Work, or related to the events giving rise to the change.

6.4 ALLOWABLE COSTS

- A. Any adjustments to the Contract Price shall be based on the following categories and shall incorporate markups for Overhead and profit as provided herein.
1. **Labor.** For all labor, including foreman supervision but excluding superintendents and other project management and consultants, the Contractor shall be reimbursed for labor costs provided herein. The labor cost of an event or condition shall be calculated as the sum of the following:
 - a. **Labor Rate.** The Labor Rate is the actual reasonable wage paid to the individual plus the actual reasonable costs incurred by the Contractor to cover costs associated with Federal Insurance Compensation Act (FICA), Federal Unemployment Tax Act (FUTA), State Unemployment Tax Act (SUCA), industrial insurance, fringe benefits, and benefits paid on behalf of labor by the Contractor. The applicable Labor Rates shall be multiplied by the number of hours reasonably expended in each labor classification because of the event or condition to arrive at a total cost of labor.
 - b. **Travel Allowance and/or Subsistence.** The labor calculation shall include the actual costs of travel and/or subsistence paid to the Contractor's employees engaged upon the Work when said payments are required by a labor agreement.
 2. **Materials.** The cost of materials resulting from an event or condition shall be calculated in one or more of the following methods, at City's election:
 - a. **Invoice Cost.** The Contractor may be paid the actual invoice cost of materials including actual freight and express charges and applicable taxes less all available discounts, rebates, and back-charges,. This method shall be considered only to the extent the Contractor's invoice costs are reasonable and the Contractor provides copies of vendor invoices, freight and express bills, and other evidence of cost accounting and payment satisfactory to City. As to materials furnished from the Contractor's stocks for which an invoice is not available, the Contractor shall furnish an affidavit certifying its actual cost of such materials and such other information as City may reasonably require;
 - b. **Wholesale Price.** The Contractor may be paid the lowest current wholesale price for which the materials are available in the quantities required, including customary costs of delivery and all applicable taxes less all available discounts, rebates, and back-charges; or

- c. **City Furnished Material.** City reserves the right to furnish such materials as it deems advisable, and the Contractor shall have no Claim for any costs, Overhead or profit on such materials. However, should the Contractor be required to pick up, transport and/or unload such materials the Contractor will be reimbursed for reasonable costs thereof.
- 3. **Equipment.** The additional cost, if any, of machine-power tools and equipment usage shall be calculated in accordance with the following rules:
 - a. **Equipment Rates.** The Contractor's own charge rates may be used if verified and approved by City and based on the Contractor's actual ownership and operating cost experience. Rental rates contained in published rate guides may be used if their cost formulas and rate factors are identifiable, reflect the Contractor's historical acquisition costs, utilization, and useful life, and do not include replacement cost, escalation contingency reserves, general and administrative expense, or profit. Rates shall be based on the Contractor's actual allowable costs incurred or the rates established according to the Rental Rate Blue Book for Construction Equipment, published by Equipment Watch, PRIMEDIA, whichever is less. The Rental Rate Blue Book established hourly equipment rate shall be the monthly rental rate for the equipment plus the monthly rental rate for required attachments, divided by 176 work hours per month, multiplied by the appropriate regional adjustment factor, plus the hourly operating cost. The established equipment rate shall apply for actual equipment usage up to eight hours per day. For all hours in excess of eight hours per day or 176 hours per month, the established equipment rate shall be the monthly rental rate plus the monthly rental rate for required attachments, divided by 352, multiplied by the regional adjustment factor, plus the hourly operating cost.
 - b. **Transportation.** If the necessary equipment is not already at the Site and it is not anticipated that it would be required for the performance of other work under the terms of the Contract, the calculation shall include a reasonable amount for the costs of the necessary transportation of such equipment.
 - c. **Standby.** The Contractor shall only be entitled to standby equipment costs if (a) the equipment is ready, able, and available to do the Work at a moment's notice; (b) Contractor is required to have equipment standby because of an event or condition solely caused by City and (c) the Contractor can demonstrate that it could have and intended to use the equipment on other projects/jobs. The Contractor shall be compensated at 50% of the monthly rental rate for the equipment, divided by 176, and multiplied by the appropriate regional adjustment factor, as identified in the Rental Rate Blue Book for Construction Equipment, published by Machinery Information Division of PRIMEDIA Information Inc. Standby shall not be paid during periods of Contractor-caused delay, concurrent delay, Force Majeure, during any seasonal shutdown, routine maintenance, down-time or broken equipment, late delivery of equipment or supplies, or other anticipated occurrence specified in the Contract Documents. No payment shall be made for standby on any piece of equipment, which has been used on the Project in any 24 hour period. Standby costs shall not be paid for weekends, holidays, and any time the equipment was not intended to be used on the Project as demonstrated by the Project Schedule.

4. **Subcontractor & Supplier.** Direct costs associated with Subcontractors and Suppliers shall exclude Overhead and Profit markups and shall be calculated and itemized in the same manner as prescribed herein for Contractor. Contractor shall provide detailed breakdown of Subcontractor and Supplier invoices.
5. **Overhead and Profit Markup.**
 - a. On a change to the Contract Price or any other claim for money by the Contractor, City will only pay Overhead, including Home Office Overhead, Site or Field Office Overhead, and unabsorbed home office overhead, and Profit pursuant to the Overhead and Profit Markups set forth herein. The Overhead and Profit Markups cover all overhead regardless of how the Contractor chooses to account for various costs in its books of account.
 - b. Overhead and Profit markups shall not be applied to freight, delivery charges, express charges, and sales tax.
 - c. The allowed Overhead and Profit markup shall not exceed the following:
 - i. If the Contractor is self-performing work: 18% combined Overhead and Profit markup on the Contractor's Direct Costs;
 - ii. If a Subcontractor or Supplier is performing work: 18% for the Subcontractor's Direct Cost for performing the work and 7% on the Direct Costs of the Subcontractors' or Suppliers'; provided that the 7% is to be divided among upper tier Subcontractors and the Contractor when a Subcontractor or Supplier is performing the work;
 - iii. If the value of material and equipment is greater than 50% of the total value of the change, the Overhead and Profit Markup shall only be 10% for material and equipment; and
 - iv. In no event shall the total combined Overhead and Profit markup for the Contractor and all Subcontractors and Suppliers of any tier exceed 25% of the Direct Cost to perform the Change Order work.

ARTICLE 7: PAYMENT AND COMPLETION

7.1 APPLICATIONS FOR PAYMENT

- A. On or about the first day of each month, the Contractor shall submit to City an Application for Payment. Each application shall be completed on a form acceptable to City and designated as an "Application for Payment."
- B. The Contractor is not entitled to payment for any work unless the Application for Payment includes all required documentation. City reserves the right to withhold payment pursuant to paragraph 7.2, *Payments Withheld* if it is subsequently determined that all required documentation was not provided by the Contractor or is in error.
- C. The application shall correlate the amount requested with the Schedule of Values and with the state of completion of the Work.
- D. The Contractor shall submit a breakdown of the cost of lump sum items to enable the Engineer to determine the Work performed on a monthly basis. Lump sum breakdowns shall be submitted prior to the first progress payment that includes

payment for the Bid Item. Absent a lump sum breakdown, the Engineer will make a determination based on information available.

7.2 PAYMENTS

- A. City shall comply with RCW 39.76, as amended, and promptly review each Application for Payment and identify in writing any cause for disapproval within 8 working days. In addition to withholding payment for unsatisfactory performance or failure to comply with Contract requirements, if the Contractor's Application for Payment fails to recognize any back-charges, off-sets, credits, change orders, or deductions in payment made in accordance with paragraph 7.2, *Payments Withheld*, City shall have the right to revise or disapprove Contractor's Application For Payment because the Application for Payment is not considered a properly completed invoice.
- B. The City shall withhold retainage from each Application for Payment as required by RCW 60.28, as amended.
- C. If an Application for Payment is accepted by City, it shall be paid within thirty (30) days of City's receipt of the properly prepared invoice (Application for Payment).

7.3 PAYMENT WITHHELD

- A. In addition to retainage withheld pursuant to RCW 60.28 and without waiver of any other available remedies, City has the right to withhold, nullify, or back-charge, in whole or in part, any payment or payments due or that have been paid to the Contractor as may be necessary to cover City's costs or to protect City from loss or damage for reasons including but not limited to:
 - 1. Failure of the Contractor to submit or obtain acceptance of a Progress Schedule, Schedule of Values, and any updated Schedules;
 - 2. Defective or non-conforming Work;
 - 3. Costs incurred by City to correct, repair or replace defective or non-conforming Work, or to complete the Work;
 - 4. A reasonable doubt that the Contract can be completed for the balance then unpaid;
 - 5. A reasonable concern by City that the materials, equipment or component parts are not in proper operating condition;
 - 6. Assessment of Liquidated Damages;
 - 7. Failure to perform in accordance with the Contract;
 - 8. Cost or liability that may occur to City as the result of the Contractor's or Subcontractor's acts, omissions, fault, or negligence;
 - 9. Deduction in the Work;
 - 10. Failure of Contractor to repair damaged materials, equipment, property, or Work;
 - 11. Failure of the Contractor to obtain approval of Submittals pertinent to the work accomplished;
 - 12. Failure to pay Subcontractors, Suppliers, employees or other obligations arising out of the Work;

13. Failure to keep Record Documents up to date;
 14. Failure to comply with all applicable federal, state, and local laws, statutes, regulations, codes, licenses, easements, and permits;
 15. Failure to obtain and maintain applicable permits, insurance, and bonds; and
 16. Failure to provide Statement of intent to Pay Prevailing Wage and/or Affidavits of Wages Paid and, if requested, Certified Payroll Records for the Contractor and for Subcontractors of any tier.
- B. The withholding, nullification, or back-charge of any payment(s) by City shall in no way relieve the Contractor of any of its obligations under this Contract.

7.4 TITLE

Title to all Work and materials covered by an accepted and paid Application For Payment shall pass to City at the time of such payment, free and clear of all liens, claims, security interest, and encumbrances. Passage of title shall not, however, (1) relieve Contractor from any of its duties and responsibilities for the Work or materials, including protection thereof, (2) waive any rights of City to insist on full compliance by Contractor with the Contract requirements, or (3) constitute acceptance of the Work or materials.

7.5 SUBSTANTIAL COMPLETION

- A. When the Contractor has achieved Substantial Completion (as defined in Section 1 above), the Contractor shall give written Notice to City.
1. City shall promptly inspect the Work and prepare a Punch List (list of items to be completed or corrected).
 - a. City reserves the right to add to, modify, or change the Punch List.
 - b. Failure by City to include any items on such list does not alter the responsibility of the Contractor to complete or correct the Work in accordance with the Contract.
- B. At the Contractor's request, City may identify those Punch List items that must be completed or corrected in order for the Contractor to achieve Substantial Completion.
1. When City determines that those Punch List items have been completed or corrected by the Contractor, City shall make a determination that the Work is Substantially Complete.
 2. A Certificate of Substantial Completion will be issued by City, which shall establish the date of Substantial Completion.
 3. This Certificate of Substantial Completion shall state the responsibilities of City and the Contractor for security, maintenance, heat, utilities, damage to the Work, and insurance.
- C. City shall assess liquidated damages for the Contractor's failure to Substantially Complete the Work within the Contract Time. The liquidated damage amounts, set forth elsewhere in the Contract Documents, will be assessed for Contractor's failure to achieve Substantial Completion within the Contract Time. These Liquidated Damages are not a penalty, but will be assessed against the Contractor for failure to achieve these Contract requirements. These Liquidated Damage amounts are

fixed and agreed upon by and between the Contractor and City because of the impracticability and extreme difficulty of fixing and ascertaining the actual damages City would in such events sustain. These amounts shall be construed as the actual amount of damages sustained by City, and may be retained by City and deducted from payments to the Contractor. Assessment of Liquidated Damages shall not release the Contractor from any further obligations or duties pursuant to the Work.

- D. As provided in the Contract Documents, City may grant Substantial Completion to specific subsystems or portions of the Work. The dates of Substantial Completion shall be determined, in writing, by City.

7.6 FINAL INSPECTION

- A. The Contractor shall correct all remaining Punch List items and complete all remaining Work within the time period stated in the Certificate of Substantial Completion or within 30 days, whichever is less. When all Punch List items have been successfully corrected and the work is complete the Contractor's shall give written notice to the City that the Work ready for final inspection. After verification by City that such completion was satisfactory, the Contractor shall submit a Final Application for Payment.

7.7 REQUIREMENTS FOR FINAL APPLICATION FOR PAYMENT

- A. In addition to any other requirement identified in the Contract Documents, the Final Application for Payment shall include the following documents:
 - 1. Affidavit of Wages Paid for Contractor and all Subcontractors in accordance with state law;
 - 2. Contractor's release of claims against City, except for Claims specifically described in the release document and submitted in accordance with Article 9, *Claims and Litigation*; and
 - 3. Contractor certification that all Subcontractors and Suppliers have been paid and there are no outstanding liens.

7.8 COMPLETION/FINAL ACCEPTANCE

- A. Completion/Final Acceptance shall be achieved when all the obligations of the Contract have been successfully performed by the Contractor in accordance with the Contract and accepted by City. Should Contractor fail to achieve Final Acceptance within the required time the City may assess actual damages caused by its failure to do so.
- B. Neither Final Acceptance, nor Final Payment, shall release Contractor or its sureties from any obligations under this Contract or the Performance and Payment Bonds, or constitute a waiver of any claims by City arising from or related to Contractor's performance or failure to perform the Work and to meet all Contractual obligations in accordance with the Contract, including but not limited to:
 - 1. Unsettled liens, security interests or encumbrances;
 - 2. Damaged, non-conforming, or defective Work discovered by City;
 - 3. Terms of any warranties or guarantees required by the Contract; and
 - 4. Payments made in error.

- C. Except for any Claims properly submitted in accordance with Article 9, *Claims and Litigation*, acceptance of Payment on the Final Application for Payment by the Contractor shall, on behalf of itself and its Subcontractors or Sureties, forever and unconditionally release and discharge City, its officers, agents, employees, from:
 - 1. Any and all disputes or claims, including but not limited to claims for damages, fines, interest, taxes, attorney fees, or costs, demands, rights, actions or causes of actions, known or unknown, arising out of or in any way related to the parties' performance under the Contract and/or Project; and
 - 2. Any and all known and/or unknown liabilities, obligations, demands, actions, suits, debts, charges, causes of action, requests for money and/or payment under the Contract, outstanding invoices, or claims directly or indirectly arising out of or related to the Contract and/or Project.

7.9 WARRANTY AND GUARANTY

- A. In addition to any special warranties provided elsewhere in the Contract, Contractor warrants that all Work conforms to the requirements of the Contract and is free from any defect in equipment, material, design, or workmanship performed by Contractor or its Subcontractors and Suppliers.
- B. The warranty period shall be for the longer period of: one year from the date of Final Acceptance of the entire Project or the duration of any special extended warranty offered by a supplier or common to the trade.
- C. With respect to all warranties, express or implied, for Work performed or materials furnished according to the Contract, Contractor shall:
 - 1. Obtain all warranties that would be given in normal commercial practice from the supplier and/or manufacturer;
 - 2. Prior to Final Acceptance require all warranties be executed, in writing, for the benefit of City;
 - 3. Enforce all warranties for the benefit of City; and
 - 4. Be responsible to enforce any warranty of a Subcontractor, manufacturer, or Supplier, should they extend beyond the period specified in the Contract.
- D. If, within an applicable warranty period, any part of the Work is found not to conform to the Contract, the Contractor shall correct it promptly after receipt of written Notice from City to do so. In the event City determines that Contractor corrective action is not satisfactory and/or timely performed, then City has the right to either correct the problem itself or procure the necessary services, recommendations, or guidance from third parties. All damages incurred by City and all costs for City's remedy shall be reimbursed by the Contractor.
- E. The warranty provided in this provision shall be in addition to any other rights or remedies provided elsewhere in the Contract or by applicable law.

7.10 PRIOR OCCUPATION

City shall have the right to occupy such part or parts of the Project in or upon which the Work is being done, as it may see fit, and such occupation shall not be construed as acceptance by City of the Work or constitute Substantial Completion of the Work.

ARTICLE 8: TERMINATION

8.1 CITY'S RIGHT TO TERMINATE CONTRACT

A. Termination for Default

1. City may terminate, without prejudice to any right or remedy of City the Work, or any part of it, for cause upon the occurrence of any one or more of the following events:
 - a. Contractor fails to prosecute the Work or any portion thereof with sufficient diligence to ensure Substantial Completion of the Work within the Contract Time;
 - b. Contractor fails to prosecute the Work or any portion thereof with sufficient diligence to ensure Final Acceptance of the Work in a timely manner;
 - c. Contractor is adjudged bankrupt, makes a general assignment for the benefit of its creditors, or a receiver is appointed on account of its insolvency;
 - d. Contractor fails in a material way to repair, replace or correct Work not in conformance with the Contract;
 - e. Contractor repeatedly fails to supply skilled workers or proper materials or equipment;
 - f. Contractor repeatedly fails to make prompt payment to its employees or Subcontractors;
 - g. Contractor materially disregards or fails to comply with laws, ordinances, rules, regulations, permits, easements or orders of any public authority having jurisdiction;
 - h. Contractor fails to comply with all Contract safety requirements; or
 - i. Contractor is otherwise in material breach of any provision of the Contract, including but not limited to quality control, environmental requirements, administrative requirements, coordination and supervision.
2. If City reasonably believes that one of the aforementioned events has occurred, City will provide the Contractor with written Notice of its intent to terminate the Contractor for default, specifying within such notice the ground(s) for such termination. City, at its option, shall require the Contractor to either promptly correct the deficiencies noted in City's intent to terminate or provide City with a corrective action plan as to how such deficiencies will be remedied or cured in a timely fashion. However, if after receipt of the proposed remedy, City has a reasonable basis for concluding that the Contractor has (a) failed or is unwilling to repair, replace or correct the deficiencies, or (b) failed or is unwilling to provide a reasonable and satisfactory corrective action plan, City shall thereafter have the right to terminate this Contract for default.
3. Upon termination, City may at its option:
 - a. Take possession of the Site and possession of or use of all materials, equipment, tools, and construction equipment and machinery thereon owned by Contractor; and/or

- b. Finish the Work by whatever other reasonable method it deems expedient; or
 - c. Call upon the surety to perform its obligations under the performance and payment bonds, if applicable.
4. The Contractor and its sureties shall be liable for all damages and costs, including but not limited to: (1) compensation for architect and engineering services and expenses made necessary thereby; (2) any other costs or damages incurred by City in completing and/or correcting the Work; and (3) any other special, incidental or consequential damages incurred by City which results or arises from the breach or termination for default.
 5. In the event of termination for default City shall only pay the Contractor for Work successfully completed and accepted by City prior to the date of termination. City shall not be responsible for any other Contractor costs, expenses, or damages including any consequential, special, or incidental damages or lost profits associated with this Contract. In no event shall City reimburse the Contractor for any costs directly or indirectly related to the cause of this termination for default.
 6. If, after termination for default, it is determined that the Contractor was not in default, the rights and obligations of the parties will be the same as if the termination had been issued for the convenience of City.
 7. The rights and remedies of City in this provision are in addition to any other rights and remedies provided by law or under this contract.

B. Termination for Convenience

1. Upon written Notice City may terminate the Work, or any part of it, without prejudice to any right or remedy of City, for the convenience of City.
2. If City terminates the Work or any portion thereof for convenience, Contractor shall recover as its sole remedy:
 - a. Reasonable costs for all Work completed prior to the effective date of the termination and not previously paid for by City; and
 - b. A reasonable allowance for Overhead and profit for Work actually performed prior to the date of termination and accepted by City, at a rate not to exceed the percentage amount set forth in the Contract and in paragraph 6.3, *Allowable Costs*, subparagraph A.5, *Overhead and Profit*. The Contractor waives all other claims for payment and damages including without limitation, anticipated profit and overhead on work not performed and accepted by City.
3. The Contractor shall not be entitled to any other costs or damages, whatsoever. The total sum payable upon termination shall not exceed the Contract Price reduced by prior payments. Contractor shall be required to make its request for adjustment in accordance with Article 5, *Changes to the Contract*, and Article 6, *Time and Price Adjustments*.
4. If it appears that the Contractor would have sustained a loss on the entire Contract had it been completed, City shall not reimburse Contractor any profit for the Work completed and shall reduce the settlement to reflect the indicated rate of loss.

C. Contractor's Obligations During Termination

Unless City directs otherwise, after receipt of a written Notice of termination for default or termination for convenience, Contractor shall promptly:

1. Stop performing Work on the date and as specified in the Notice of termination;
2. Place no further orders or subcontracts for materials, equipment, services or facilities, except as may be necessary for completion of such portion of the Work not terminated;
3. Cancel all orders and subcontracts, upon terms acceptable to City, to the extent that they relate to the performance of Work terminated;
4. Assign as specifically requested by City all of the rights, title, and interest of Contractor in all orders and subcontracts;
5. Take such action as may be necessary or as directed by City to preserve and protect the Work, Site, and any other property related to this Project in the possession of Contractor in which City has an interest;
6. Continue performance of Work only to the extent not terminated; and
7. Take any other steps required by City with respect to this Project.

8.2 CITY'S RIGHT TO STOP THE WORK FOR CAUSE

- A. If Contractor fails or refuses to perform its obligations in accordance with the Contract, City may order Contractor, in writing, to stop the Work, or any portion thereof, until satisfactory corrective action has been taken.
- B. Contractor shall not be entitled to any adjustment in the Contract Time and/or Contract Price for any increased cost or time of performance attributable to Contractor's failure or refusal to perform its obligations under the Contract.

ARTICLE 9: CLAIMS AND LITIGATION

9.1 CONTRACTOR CLAIMS

A. Condition Precedent to Filing a Claim.

1. The following actions are a condition precedent to filing a Claim:
 - a. The Contractor submitted a timely Notice of Protest, Supplemental Information and Request for Change Order as required by paragraph 5.1;
 - b. The Request for Change Order has been denied or deemed denied by City;
or
 - c. A Unilateral Change Order is issued by City.

B. Failure to file a Timely Claim.

1. At least seven (7) days prior to appropriate time to file a Claim, the Contractor may request an extension of time for filing its Claim. The Contractor shall state the reasons for the request and identify a date certain when the Contractor shall provide a fully documented Claim. Unless otherwise agreed to in writing by the Engineer, a fully documented Claim shall be received by the City within thirty (30) days after:
 - a. Denial or deemed denial of a Request for Change Order; or

- b. Contractor's receipt of an Executed Unilateral Change Order.
- 2. Failure to comply with the time requirements set for filing a Claim shall constitute acceptance by the Contractor, on behalf of itself and its Subcontractors and Suppliers, of the Unilateral Change Order and/or City's denial or deemed denial of a Request for Change Order. Such acceptance shall be considered complete, full, and final settlement of all costs, damages, and Claims related to or arising from the Request for Change Order and/or Unilateral Change Order.
- C. Contractor's Obligation to Continue to Work. Pending final decision of a Claim hereunder, the Contractor shall proceed diligently with the performance of the Contract Work, including that work associated with the Claim, and maintain its progress with the Work.
- D. Information required in a Fully Documented Claim. Every Claim must be submitted by the Contractor, in writing and clearly designated by the Contractor as a fully documented Claim. At a minimum, a fully documented Claim must contain the following information:
 - 1. A detailed factual statement of the Claim providing all necessary details, locations, and items of Contract Work affected;
 - 2. The date on which facts arose that gave rise to the Claim;
 - 3. The name of each person employed or associated with the Contractor, Subcontractor, Supplier, and/or City with knowledge about the event or condition which gave rise to the Claim;
 - 4. Copies of documents and a written description of the substance of any oral communications that concern or relate to the Claim;
 - 5. The specific provisions of the Contract Documents on which the Claim is based;
 - 6. If an adjustment in the Contract Price is sought, the exact amount sought, calculated in accordance with the Contract including paragraph 6.3, *Allowable Cost* and accompanied by (a) all records supporting the Claim and (b) all records meeting the requirements of paragraph 3.10, *Cost Records*;
 - 7. If an adjustment in the Contract Time is sought, the specific days and dates for which it is sought; the specific reason the Contractor believes an adjustment in the Contract Time should be granted; and the Contractor's analyses of its Progress Schedule, any specific Schedule analysis as required by the Contract Documents, and all updates to demonstrate the reason for the adjustment in Contract Time; and
 - 8. A statement certifying, under penalty of perjury, that after the exercise or reasonable diligence and investigation the Claim is made in good faith, that the supporting cost and pricing data are true and accurate to the best of the Contractor's knowledge and belief, that the Claim is fully supported by the accompanying data, and that the amount requested accurately reflects the adjustment in the Contract Price or Contract Time for which the Contractor believes City is liable.
- E. Contractor's Duty to Cooperate. The Contractor shall cooperate with City or its designee in the evaluation of its Claim and provide all information and documentation requested by City, its auditors or its designee.

F. City's Evaluation of the Claim.

1. To assist City in the review of the Contractor's Claim, City or its designee may visit the Site, request additional information and/or documentation in order to fully evaluate the issues raised in the Claim and/or audit the Claim.
2. After the Contractor has submitted a fully documented Claim that complies with this provision, City shall respond, in writing, to the Contractor within sixty (60) days from the date the fully documented Claim is received with either:
 - a. A decision regarding the Claim; or
 - b. Written Notice extending for another thirty (30) days City's time to respond to the Claim.
3. Absent a thirty (30) day extension, the Claim shall be deemed denied upon the sixty-first (61st) day following receipt of the Claim by City. If City had a thirty (30) day extension, the Claim shall be deemed denied upon the ninety-first (91st) day following receipt of the Claim by City.

9.2 CONTRACTOR'S BURDEN OF PROOF ON CLAIM

- A. The Contractor shall have the burden of proof to demonstrate entitlement and damages.
- B. If the Contractor, on behalf of itself or its Subcontractors and Suppliers seeks an adjustment in the Contract Price or Contract Time not supported by Project cost records meeting the requirements of ¶3.10, *Cost Records*, the Claim is waived.
- C. Compliance with the record keeping requirements set forth in this Contract is a condition precedent to recovery of any costs or damages related to or arising from performance of the Contract Work. If City establishes non-compliance of the record-keeping requirement set forth in ¶ 3.10, *Cost Records*, no adjustment shall be made to the Contract Price and/or Contract Time with respect to that Claim.

9.3 LITIGATION

- A. As a mandatory condition precedent to the initiation of litigation by the Contractor against City, Contractor shall comply with all provisions set forth in this Contract including those stated in Article 5 and Article 9.
- B. Any litigation brought against City shall be filed and served on City within 365 days from either the issuance of the Certificate of Substantial Completion for the entire Contract or Final Acceptance if no Certificate of Substantial Completion of the entire Contract is issued.
- C. Venue and jurisdiction shall vest solely in the King County Superior Court.
- D. Failure to comply with these mandatory condition time requirements shall constitute a waiver of the Contractor's right to pursue judicial relief from or against the City.

ARTICLE 10: MISCELLANEOUS

10.1 COMPENSATION, WAGES, BENEFITS AND TAXES

City assumes no responsibility for the payment of any compensation, wages, benefits, or taxes owed by the Contractor by reason of this Contract. The Contractor shall indemnify and hold City, its elected officials, officers, agents and employees, harmless

against all liability and costs resulting from the Contractor's failure to pay any compensation, wages, benefits or taxes.

10.2 PREVAILING WAGES

The Contractor shall comply with the minimum wage requirements of RCW 39.12, as amended, including the obligation to pay at least the hourly minimum wage and fringe benefits to workers as required by RCW 39.12. The Contractor shall also post all notices required by the Washington Department of Labor & Industries on forms provided by the Department of Labor & Industries. The Contractor shall timely provide a "Statement of Intent to Pay Prevailing Wages" and timely provide an "Affidavit of Prevailing Wages Paid."

10.3 SUCCESSORS AND ASSIGNS

City and the Contractor each binds itself, its partners, successors, assigns and legal representatives to the other with respect to all covenants, agreements and obligations contained in the Contract. Neither party to the Contract shall assign the Contract or sublet it as a whole without the written consent of the other, nor shall the Contractor assign any moneys due or to become due to it hereunder, without the previous written consent of City.

10.4 THIRD PARTY AGREEMENTS

Except as otherwise may be provided, the Contract shall not be construed to create a contractual relationship of any kind between: any architect, engineer, construction manager, Subcontractor, Supplier, or any persons other than City and Contractor.

10.5 NONWAIVER OF BREACH

No action or failure to act by City shall constitute a waiver of any right or duty afforded to City under the Contract; nor shall any such action or failure to act by City constitute an approval of or acquiescence in any breach hereunder, except as may be specifically stated by City in writing.

10.6 NOTICE TO CITY OF LABOR DISPUTES

- A. If Contractor has knowledge that any actual or potential labor dispute is delaying or threatens to delay timely performance in accordance with the Contract, Contractor shall immediately give Notice, including all relevant information, to City.
- B. Contractor agrees to insert a provision in its Subcontracts and to require insertion in all sub-subcontracts, that in the event timely performance of any such contract is delayed or threatened by any actual or potential labor dispute, all Subcontractor or lower-tiered Subcontractor shall immediately notify the next higher tier Subcontractor. Subcontractor or Contractor, as the case may be, of all relevant information concerning the dispute.

10.7 HEADINGS

The headings used in the Contract are for convenience only and shall not be considered a part of or affect the construction or interpretation of any contractual provision therein.

10.8 CHOICE OF LAW

In the event that either party shall bring a lawsuit or action related to or arising out of this Contract, such lawsuit or action shall be brought in the Superior Court, King County,

Washington. This Contract shall be governed by, and construed and enforced in accordance with the laws of the State of Washington.

10.9 SEVERABILITY

The provisions of this Contract shall be effective in all cases unless otherwise prohibited by Washington State Law or applicable Federal Law. The provisions of this Contract are separate and severable. The invalidity of any sentence, paragraph, provision, section, Article, or portion of this Contract shall not affect the validity of the remainder of this Contract.

SUPPLEMENTAL CONDITIONS

“Supplemental Conditions” contains portions of Division 1 of the 2022 Standard Specifications for Road, Bridge, and Municipal Construction, prepared by the Washington State Department of Transportation (WSDOT). Section 1-01 to Section 1-09 of Division 1 are deleted and replaced by the “General Terms and Conditions” included in this document. The entire content of Section 1-10 “Temporary Traffic Control” remains in effect, along with revisions and supplements provided within this Section.

1-05 CONTROL OF WORK

1-05.18 Record Drawings (March 8, 2013 APWA GSP)

The Contractor shall maintain one set of full-size plans for Record Drawings, updated with clear and accurate red-lined field revisions on a daily basis, and within 2 business days after receipt of information that a change in Work has occurred. The Contractor shall not conceal any work until the required information is recorded.

This Record Drawing set shall be used for this purpose alone, shall be kept separate from other Plan sheets, and shall be clearly marked as Record Drawings. These Record Drawings shall be kept on site at the Contractor's field office and shall be available for review by the Contracting Agency at all times. The Contractor shall bring the Record Drawings to each progress meeting for review.

The preparation and upkeep of the Record Drawings is to be the assigned responsibility of a single, experienced, and qualified individual. The quality of the Record Drawings, in terms of accuracy, clarity, and completeness, is to be adequate to allow the Contracting Agency to modify the computer-aided drafting (CAD) Contract Drawings to produce a complete set of Record Drawings for the Contracting Agency without further investigative effort by the Contracting Agency.

The Record Drawing markups shall document all changes in the Work, both concealed and visible. Items that must be shown on the markups include but are not limited to:

- Actual dimensions, arrangement, and materials used when different than shown in the Plans.
- Changes made by Change Order or Field Order.
- Changes made by the Contractor.
- Accurate locations of storm sewer, sanitary sewer, water mains and other water appurtenances, structures, conduits, light standards, vaults, width of roadways, sidewalks, landscaping areas, building footprints, channelization and pavement markings, etc. Include pipe invert elevations, top of castings (manholes, inlets, etc.).

If the Contract calls for the Contracting Agency to do all surveying and staking, the Contracting Agency will provide the elevations at the tolerances the Contracting Agency requires for the Record Drawings.

When the Contract calls for the Contractor to do the surveying/staking, the applicable tolerance limits include, but are not limited to the following:

	<u>Vertical</u>	<u>Horizontal</u>
As-built sanitary & storm invert and grate elevations	± 0.01 foot	± 0.01 foot
As-built monumentation	± 0.001 foot	± 0.001 foot
As-built waterlines, inverts, valves, hydrants	± 0.10 foot	± 0.10 foot
As-built ponds/swales/water features	± 0.10 foot	± 0.10 foot
As-built buildings (fin. Floor elev.)	± 0.01 foot	± 0.10 foot
As-built gas lines, power, TV, Tel, Com	± 0.10 foot	± 0.10 foot
As-built signs, signals, etc.	N/A	± 0.10 foot

Making Entries on the Record Drawings:

- Use erasable colored pencil (not ink) for all markings on the Record Drawings, conforming to the following color code:
 - Additions - Red
 - Deletions - Green
 - Comments - Blue
 - Dimensions - Graphite
- Provide the applicable reference for all entries, such as the change order number, the request for information (RFI) number, or the approved shop drawing number.
- Date all entries.
- Clearly identify all items in the entry with notes similar to those in the Contract Drawings (such as pipe symbols, centerline elevations, materials, pipe joint abbreviations, etc.).

The Contractor shall certify on the Record Drawings that said drawings are an accurate depiction of built conditions, and in conformance with the requirements detailed above. The Contractor shall submit final Record Drawings to the Contracting Agency. Contracting Agency acceptance of the Record Drawings is one of the requirements for achieving Physical Completion.

1-10 TEMPORARY TRAFFIC CONTROL

To disrupt public traffic as little as possible, the Contractor shall permit traffic to safely pass through the work with the least possible inconvenience or delay. The Contractor shall maintain existing roads, streets, sidewalks, and paths within the project limits, keeping them open, and in good, clean, safe condition at all times. Contractor is to develop, publish, and post on site specific traffic control plans for vehicles, pedestrians, bicycles, Mercer Island school busses, Metro busses, equestrians, and persons with disabilities. Deficiencies caused by the Contractor's operations shall be repaired at the Contractor's expense. Deficiencies not caused by the Contractor's operations shall be repaired by the Contractor when directed by the Engineer, at the Contracting Agency's expense. The Contractor shall also maintain roads, streets, sidewalks, and paths adjacent to the project limits when affected by the Contractor's operations. The Contractor shall perform the following:

1. The Contractor shall submit a detailed construction plan which identifies pavement cutting; pavement, walkway removals; trenching, pipe laying, backfilling and trench restoration; landscaping restoration; and final cleanup prior to beginning the work.
2. The Contractor shall maintain at least one lane of alternating 2-way traffic. Lane closure is allowable with advanced written approval from the City of Mercer Island; vehicle waits shall be limited to 5 minutes; excluding emergency medical or fire response vehicles which shall have immediate access.
3. The Contractor shall not block access to businesses or homes unless coordinated in advance and in writing with the property owner.

4. The Contractor shall not store any materials on the street overnight, unless otherwise authorized by the Engineer. Those materials stored on the street during working hours are to be used completely during the day in which they are stored. Equipment and vehicles may be parked on the public right-of-way overnight as authorized by the Engineer, but shall not interfere with traffic, pedestrian travel, driveway access, or resident parking.
5. The Contractor shall clear the work site at the end of every work day by the time specified as normal working hours and shall have completed all backfilling, temporary paving, removed all unused materials, and swept up all debris, dirt and excess materials and removed them from the street and walkways. Steel plates may be used only for pre-digging connections or when CDF is required as backfill. The edges of the plates shall be ramped with temporary hot mix asphalt to provide a smooth transition to the existing pavement.
6. Public access to residential streets shall be maintained throughout the project. Maintain driveways to properties which do not have another access and schedule their construction to minimize the impact to the property owner.
7. Safe routes for pedestrians shall be provided through the entire length of the project.
8. Remove or repair any condition resulting from the work that might impede traffic or create a hazard.
9. Maintain existing permanent signing. Repair of signs will be at the Contracting Agency's expense, except those damaged due to the Contractor's operations.
10. Keep drainage structures clean to allow for free flow of water. Cleaning of existing drainage structures will be at the Contracting Agency's expense when approved by the Engineer, except when flow is impaired due to the Contractor's operations.

During the school year (prior to June 23rd, 2022 and after August 30th, 2022) work hours in SE 40th St will be limited to 9am to 3pm. Only potholing will be allowed outside of these special hours, within normal working hours set forth in these specifications.

No construction activity will be allowed during Seafair weekend (August 5-7, 2022).

1-10.1(2) Description

(May 25, 2006 APWA GSP)

Revise the third paragraph to read:

The Contractor shall provide signs and other traffic control devices not otherwise specified as being furnished by the Contracting Agency. The Contractor shall erect and maintain all construction signs, warning signs, detour signs, and other traffic control devices necessary to warn and protect the public at all times from injury or damage as a result of the Contractor's operations which may occur on highways, roads, streets, sidewalks, or paths. No work shall be done on or adjacent to any traveled way until all necessary signs and traffic control devices are in place.

All traffic control must comply with the requirements of the Manual on Uniform Traffic Control Devices (MUTCD), including but not limited to flagging, signage, and all other traffic control devices used. Sample Section K traffic control plans published by WSDOT are available in the Appendix of

these Specifications as a guide for developing a site specific traffic control plan. The Contractor shall submit a site-specific traffic control plan for all work within the project limits for review and approval by the City prior to beginning construction.

1-10.2 Traffic Control Management

1-10.3(1)A Flaggers and Spotters *Supplement*

A minimum of two (2) flaggers will be required at all times.

1-10.3(3)A Construction Signs
(Special Provision) *Supplement*

Construction Identification Signs

Seven working days prior to commencement of work the Contractor shall pick up project notification signs from the City's Maintenance Warehouse Facility located at 9601 SE 36th, Mercer Island, WA 98040, and install on each approach to the project or as directed by the Engineer. The signs will be furnished by the City.

Contractor shall install signs at locations directed by the City. Contractor to move project signs as work progresses as directed by the City.

All costs in connection with the delivery, installation, and maintenance of the signs, the removal at the Substantial Completion Date of the project, and the furnishing, installation, maintenance, removal, and site restoration at the Substantial Completion Date of the project shall be considered **incidental** to and included in the unit contract prices of other items in this contract.

The Contractor shall return the signs in good condition to the City's Maintenance Warehouse upon completion of the project.

TECHNICAL SPECIFICATIONS

This Page Intentionally Left Blank

CITY OF MERCER ISLAND INTRODUCTION TO THE TECHNICAL SPECIFICATIONS

The accompanying Plans and these Specifications and any Addenda thereto, show and describe the location and type of work to be performed for the **2022 Water System Improvements Project**.

These Technical Specifications are intended to supplement Division 2 through Division 9 of the 2022 Standard Specifications for Road, Bridge, and Municipal Construction, prepared by the Washington State Department of Transportation (WSDOT) and the American Public Works Associations, Washington State Chapter and any amendments thereto, herein referred to as Standard Specifications. In case of conflict, these Technical Specifications shall take precedence over the Standard Specifications.

HEADINGS

Headings to parts, sections, forms, articles, and sub-articles are inserted for convenience or reference only and shall not affect the interpretation of the contract documents.

SPECIAL PROVISION'S STRUCTURE

The specifications noted herein are in addition to, or as a replacement for, the Standard Specifications. Where sections are marked "Revised Section," the specifications herein are intended to be a revision or partial revision to the Specifications section noted. Where sections are marked as "New Section," the specifications herein will be an addition to the Standard Specifications section noted. Where sections are marked "Supplement," the specifications herein are to be a supplement to the Standard Specifications section noted. Sections of the Standard Specifications that are not modified or replaced as addressed in these Technical Specifications shall remain as described in the Standard Specifications.

**DIVISION 2
EARTHWORK**

2-01 CLEARING, GRUBBING, AND ROADSIDE CLEANUP

2-01.1 Description

(Special Provision)

Supplement

The Contractor shall not disturb or damage existing trees on the project site unless specifically identified for removal on the plans and shall contact the Engineer if there is any conflict between the Plans and field conditions. All costs of protecting existing trees from damage shall be **incidental** and no separate payment shall be made for this work.

Grading Around Trees: Where excavating, or filling within the branch spread of trees that are to remain, the work shall be performed as follows:

- *Trenching:* When trenching occurs around trees to remain, the tree roots shall not be cut, but the trench shall be tunneled under or around the roots by careful hand-digging and without injury to the roots.
- *Raising Grades:* When the existing grade at tree is below the new finished grade and fill not exceeding sixteen (16) inches is required, clean washed gravel graded from one- to two-inch size shall be placed directly around the tree trunk. The gravel shall extend out from trunk on all sides a minimum of eighteen (18) inches and finish approximately two (2) inches above the finished grade at tree. Install gravel and cover with filter fabric before any earth fill is placed. New earth fill shall not be left in contact with the trunks of any trees requiring fill.
- Trees marked for preservation that are buried in fills over sixteen (16) inches deep shall have an open dry well of durable masonry (without mortar) situated at least twelve (12) inches from the tree trunk. All wells are to be properly drained. Before fills of over sixteen (16) inches are made upon the tree root areas, it is advisable to spread at least a six (6) inch minimum layer of broken stone or coarse gravel covered by inverted sod shall be spread to facilitate proper drainage and aeration.
- *Lowered Grades:* Existing trees in areas where the new finished grade is to be lowered, shall have regrading work done by hand to elevation as indicated. Roots as required shall be cut cleanly three (3) inches below finished grade and cuts covered with tree paint. Trees marked for preservation that are located more than six (6) inches above proposed grades shall stand on broad rounded mounds and be graded smoothly into the lower level. Exposed or broken roots shall be cut clean and covered with topsoil.

2-01.2 Disposal of Usable Material and Debris

2-01.2(2) Disposal Method No. 2 – Waste Site

(Special Provision)

Supplement

No waste site has been provided for the disposal of excess or excavated materials. The Contractor shall make his or her own arrangements for obtaining wastes sites in accordance with Section 2-03.3(7)C of the Standard Specifications and these Technical Specifications. All costs involved shall be considered **incidental** to and included in the unit contract price for other items in this contract.

2-02 REMOVAL OF STRUCTURES AND OBSTRUCTIONS

2-02.1 Description

(Special Provision)

Supplement

All work associated with removals shall be included in the bid item for “XX-inch D.I. Class 52 Water Main”, and “X-inch Water Service, X Side”, unless specifically covered under a separate bid item.

2-02.3 Construction Requirements

(Special Provision)

Supplement

Existing trees, landscaping and plantings, utility boxes, signs, meters, bollards, mailboxes, posts, etc. located near the construction which conflict with the work shall be removed and replaced, or relocated, in a manner satisfactory to the Engineer to allow for construction. All costs involved, except for those involving underground removals, shall be included in the force account price for Property and Landscape Restoration.

2-02.3(3) Removal of Pavement, Sidewalks, Curbs, and Gutters

(Special Provision)

Supplement

Asphalt pavement shall be milled in such a fashion to form a neat break line. Cement concrete roadways, driveways and walkways that need to be removed shall be vertically sawcut full depth with straight, uniform edges, as marked or directed by City Inspector, unless otherwise noted on the Plans.

2-02.3(3)A Removing Asphalt Concrete Pavement

(Special Provision)

New Section

Existing asphalt concrete pavement shall be removed and replaced at the locations shown in the Plans and where designated by the Engineer. This work shall be performed where shown in the Plans in accordance with Section 2-02.3(3) of the Standard Specifications and these Technical Specifications.

Removal shall be accomplished by milling along the boundaries of the area to be removed. Milling shall be accomplished as previously specified with a self-propelled machine capable of cutting to a twelve (12) inch depth and approved by the Engineer. The use of pneumatic hammers or punches will not be permitted.

Care shall be taken in removing the pavement not to damage any of the existing pavement that is to remain in place. Any remaining asphalt concrete pavement damaged due to the Contractor's operations shall be replaced by the Contractor, to the satisfaction of the Engineer at the Contractor's expense.

Removal shall be accomplished using an asphalt milling attachment that grinds the asphalt pavement in place as approved by the Engineer. The Contractor shall submit a proposed plan to the Engineer for approval for asphalt removal. The plan shall identify the equipment and methods to be used for the removal and disposal of the pavement. The pulverized pavement may be used as trench backfill material in the area above the pipe zone and twelve (12) inches below the asphalt patch as approved by the Engineer.

2-02.3(3)B Removing Cement Concrete Pavement

(Special Provision)

New Section

Existing cement concrete pavement shall be removed and replaced at the locations shown in the Plans and where designated by the Engineer. This work shall be performed where shown in the Plans in accordance with Section 2-02.3(3) of the Standard Specifications and these Technical Specifications.

Removal shall be accomplished by saw cutting along the boundaries of the area to be removed. Sawcutting shall be accomplished with a self-propelled machine capable of cutting to a twelve (12) inch depth and approved by the Engineer. The use of pneumatic hammers or punches will not be permitted.

Care shall be taken in removing the pavement not to damage any of the existing pavement that is to remain in place. Any remaining cement concrete pavement damaged due to the Contractor's operations shall be replaced by the Contractor, to the satisfaction of the Engineer at the Contractor's expense.

2-02.3(3)C Removing and/or Resetting of Miscellaneous Items

(Special Provision)

New Section

The Contractor shall remove and/or reset miscellaneous items as described in the Plans and as necessary to satisfactorily complete the work. The items requiring resetting shall be protected from damage during removal as far as is practical. If in the opinion of the Engineer an item requires replacement due to the Contractor's negligence it shall be replaced in kind at the Contractor's expense.

2-02.3(3)D Sawcutting and Milling

(Special Provision)

New Section

All asphalt pavements in the roadway to be removed and/or restored shall be milled. All concrete roadways, curbs, gutters, sidewalks and driveways to be removed shall be sawcut where removals abut other pavement to remain or shall be removed to an existing construction joint. For the purposes of this Contract, all sawcutting and all milling necessary to satisfactorily remove items listed above shall be considered **incidental** to and included in the various bid items and no additional payments will be made. All sawcutting and milling necessary to install new improvements shall be considered **incidental** to unit contract price of the type and size of material installed.

The Contractor shall include in the various other bid items all costs necessary to provide milling as required by the Standard Specifications and these Technical Specifications.

The Contractor shall be responsible for ensuring that special precautions are undertaken so that no concrete or concrete by-products, or products and by-products used in the sawcutting of concrete or milling of asphalt are discharged into any storm drain or surface water system.

In accordance with the Department of Ecology guidelines, wastewater from Portland Cement Concrete, masonry, and asphalt concrete cutting operations shall not be discharged to storm drainage systems or surface waters. Cutting operations increase the pH of wastewater; therefore filtering prior to discharge is not acceptable.

To thoroughly clean sawcuts where necessary, the Contractor shall use high pressure water (high pressure water is considered greater than 1400 psi).

All wastewater shall be collected using a wet-dry vacuum or pumped into drums for disposal. Impervious surfaces contaminated with sediment and grit from cutting or milling operations shall be cleaned by sweepers to prevent contaminants from entering the storm drainage system or surface waters when it rains.

Collection of wasted water with vacuum system, and pollution control shall be considered **incidental** to other bid items in the contract.

2-02.3(4) Removal of Existing Piping

(Special Provision)

New Section

Where indicated in the plans, required, and as directed by the Engineer or Contracting Agency, the Contractor shall excavate, remove and dispose of or abandon in-place existing piping (storm sewer, water main or sanitary sewer), and appurtenances. Excavated areas shall be backfilled in accordance with Section 2-09.

2-03 ROADWAY EXCAVATION AND EMBANKMENT

2-03.1 Description

(Special Provision)

Supplement

For the purposes of this contract, Roadway Excavation Including Haul shall not be measured and shall be **incidental** to the water main installation.

2-03.3 Construction Requirements

2-03.3(7) Disposal of Surplus Material

(Special Provision)

Supplement

All costs associated with hauling surplus materials to a disposal site will be considered **incidental** to the various bid items of the project and no additional compensation will be made.

2-03.3(7)C Contractor-Provided Disposal Site

(Special Provision)

Supplement

No waste site has been provided by the City for the disposal of material and debris. The Contractor shall make all arrangements, at Contractor's expense, for the disposal of waste materials and shall protect the City from any and all damages arising therefrom.

2-04 HAUL

2-04.1 Description

(Special provision)

Supplement

In reference to the term "haul" as used in Section 2-04 and Section 2-09.3(1)D of the Standard Specifications, all costs and expense involved in haul will be considered **incidental** to the unit contract prices of the bid items and no additional compensation will be made.

2-06 SUBGRADE PREPARATION

2-06.1 Description

(Special provision)

Supplement

Subgrade preparation shall include preparing roadbeds, curbs, curbs and gutters, sidewalks, driveway approaches, driveways, or any other permanent hard surface improvement for base material or final surfacing.

2-06.3 Construction Requirements

(Special provision)

Supplement

Compaction of the subgrade shall be considered **incidental** to and included in the unit contract prices of other items in the contract, and all costs thereof shall be included by the Contractor in other pay items. The subgrade shall be shaped and maintained to drain at all times during construction, including temporary ditches, and modifications to drainage structures necessary to eliminate standing water on the subgrade.

During the period of subgrade exposure local traffic will be allowed on the subgrade. All costs of protection of the subgrade, including replacement of damaged or contaminated suitable material, shall be considered **incidental** to and included in the unit contract prices for other items in the contract.

2-09 STRUCTURE EXCAVATION

2-09.3(1)E Backfilling

(Special Provision)

Supplement

Ethafoam 220 shall be used at all utility crossings in which there is less than six (6) inches of vertical separation between the new main or hydrant lead and the existing utilities.

CDF may be required at locations as determined by the Inspector or Engineer. The area backfilled with CDF shall be covered with steel plates until the CDF has sufficient time to cure as determined by the Inspector or Engineer. Plates shall be ramped with temporary hot mix asphalt to provide a smooth transition to the existing pavement.

2-11 TRIMMING AND CLEANUP

2-11.3 Construction Requirements

(Special provision)

Supplement

The Contractor shall take every possible precaution to preserve the existing improvements to remain. All damages to existing improvements from the Contractor's operation, whether within the road right of way or in private property, shall be the sole responsibility of the Contractor to remedy. All such areas shall be restored to their preconstruction equivalent to the satisfaction of the Owner.

All areas disturbed by the Contractor shall be smoothed, finished, cleaned, and dressed to appear uniform in all respects in accordance with Section 2-11 of the Standard Specifications.

**DIVISION 3
AGGREGATE PRODUCTION AND ACCEPTANCE**

3-01 PRODUCTION FROM QUARRY AND PIT SITES

3-01.4 Contractor Furnished Material Sources

(Special Provision)

Supplement

If the source of materials provided by the Contractor necessitates hauling over roads other than City streets, the Contractor shall at his or her own expense make all arrangements for the use of haul routes.

**DIVISION 4
BASES**

4-04 BALLAST AND CRUSHED SURFACING

4-04.2 Materials

(Special Provision)

Supplement

Crushed surfacing shall meet the requirements of section 9-03.9(3) of the Standard Specifications, except that recycled materials will not be allowed.

**DIVISION 5
SURFACE TREATMENTS AND PAVEMENTS**

5-04 HOT MIX ASPHALT

5-04.2 Materials

(Special Provision)

Supplement

The grade of paving asphalt shall be Commercial HMA Class B unless otherwise directed by the Engineer.

5-04.2(2)A Mix Design

(Special Provision)

New Section

1. General. Prior to the production of HMA, the Contractor shall determine a design aggregate structure and asphalt binder content in accordance with WSDOT Standard Operating Procedure 732. Once the design aggregate structure and asphalt binder content have been determined, the Contractor shall submit the HMA mix design on DOT form 350-042 demonstrating the design meets the requirements of Sections 9-03.8(2) and 9-03.8(6) of the Standard Specifications. Verification of the mix design by the Contracting Agency is not needed. The Project Engineer will determine anti-strip requirements for the HMA.

The mix design will be the initial Job Mix Formula (JMF) for the class of mix. Any additional adjustments to the JMF will require the approval of the Project Engineer and may be made per Section 9-03.8(7) of the Standard Specifications.

2. Non-Statistical Evaluation. Non statistical acceptance will apply to all HMA not designated as Commercial HMA in the contract documents. Non statistical acceptance testing will be conducted as outlined in 5-04.3(8)A of the 2016 standard specifications.
3. Commercial Evaluation. Where Commercial HMA is allowed it can be accepted by a Manufacturer's Certificate of Compliance stating the material meets the requirements in the contract. Where HMA Commercial is used for the traveled way, a minimum of one acceptance test to verify gradation, fracture, sand equivalent, and oil content is required in addition to the Manufacturer's Certificate of Compliance.

5-04.3(4)D Thickened Edges and Berms

(Special Provision)

New Section

Where existing thickened edges or berms are disturbed or as directed by the Engineer, the Contractor shall reconstruct thickened edges and berms to match the existing condition, without changing any existing drainage patterns.

Reconstruction of thickened edges, berms, and asphalt transitions will be paid for under the bid item for "Hot Mix Asphalt (HMA) Class B Permanent Trench Patch".

5-04.3(4)E Incidental Uses for HMA

(Special Provision)

New Section

Incidental uses for hot mix asphalt shall consist of adjustment to utilities, adjustment to paved areas such as the back of sidewalks, sidewalk ramps, behind driveway approaches, feathering joints and other such uses as directed by the Engineer.

Incidental uses for HMA shall be measured and paid as “Hot Mix Asphalt (HMA) Class B Permanent Trench Patch”.

5-04.3(9) HMA Mixture Acceptance

(Special Provision)

Supplement

General

Acceptance of HMA shall be as provided under nonstatistical or commercial evaluation.

Sampling of HMA for nonstatistical evaluation will be as discussed in WSDOT Standard Specifications for Road, Bridge, and Municipal Construction, 2014 edition, Section 5-04.3(8)A, sections 3 through 6.

Commercial evaluation will be used for Commercial HMA and other classes of HMA as allowed by the contract. Commercial HMA may be used for amounts of HMA less than 2500 tons in any application. Testing beyond that specified in 5-04.3(7)A, 2016 edition, item 3 for Commercial HMA will be at the discretion of the engineer. Anti-strip additive, where required, will be verified and documented by the engineer.

Aggregates

The acceptance criteria for aggregate properties of sand equivalent, voids in mineral aggregate (VMA), fracture and gradation will be their conformance to the requirements of Section 9-03.8(2) the Standard Specification, 2014 edition.

5-04.3(10) HMA Compaction Acceptance

(Special Provision)

Revised Section

The City shall provide compaction testing by others.

5-05 CEMENT CONCRETE PAVEMENT

5-05.3 Construction Requirements

(Special Provision)

Supplement

This item is intended to cover the work of replacing and repairing existing cement concrete sidewalks, curbs, and driveways that are damaged during construction to relocate water services. The contractor is to match the existing sidewalk, curb, and driveway thickness with new cement concrete sidewalk, curb, or driveway replacement. The extent of the sidewalk, curb, or driveway repair area shall be as determined by the Inspector in the field.

5-05.3(1) Concrete Mix Design for Paving

(Special Provision)

Supplement

Concrete shall be a minimum of 4,000 PSI high-early strength mix design. Contractor shall submit a proposed mix design to the engineer for approval.

**DIVISION 7
DRAINAGE STRUCTURES, STORM SEWERS, SANITARY SEWERS, WATER MAINS, AND CONDUITS**

7-00 GENERAL MATTERS

7-00.1 General

(Special Provision)

Contractor submittal of Traffic Control Plans is required for the Right-of-Way Use Permit which must be obtained by the Contractor prior to the start of any work on the City's public Right-of-Way. No fees will be charged to the Contractor for the Right-of-Way Use Permit. The Traffic Control Plans should detail how traffic is to be directed or rerouted. The plans shall include maps showing detour routes, signing, barricades, and flagging personnel.

The Contractor shall pay a deposit of \$2,900 at the Community Planning & Development counter and pick up a hydrant meter with backflow device from the City maintenance shop warehouse prior to the start of construction. All water used for construction, including fill the water main for pressure testing and flushing the main for water quality testing shall be obtained through the meter at a rate equal to \$11.09 per CCF from 6/1 to 9/30, and \$4.46 per CCF all other times for the 2022 construction year. The hydrant meter assembly shall be tested and certified EACH time it is disconnected and/or relocated to another location. The hydrant meter apparatus shall be returned to the City maintenance shop warehouse in the same condition it was checked out from the warehouse at the end of construction. A Washington State Certified Backflow Assembly tester must test and provide a report to the City Inspector EACH TIME before the assembly is connecting to the City Water System. All costs associated with the testing and maintenance of the backflow assembly shall be incidental to various bid items.

The following telephone numbers of utility companies known or suspected of having facilities within the project limits are supplied for the Contractor's convenience:

City of Mercer Island Utilities
Casey Leyde
206-960-0830

Comcast Cable
1-800-266-2278
Push #2 to report hit or damaged line

Puget Sound Energy (Gas & Power)
1-888-225-5773

Century Link
1-800-244-1111
Push #2 to report hit or damaged line

Shorewood Manager
Molly Moore
206-232-1300
shorewoodmgr@greystar.com

The Contractor shall give seventy-two (72) hours notice to all utility companies/agencies involved where work is to take place and in all other respects comply with the provisions of Chapter 19.122 RCW.

For the convenience of the Contractor, the Plans show approximate locations of various existing utilities and other obstructions. This information, if shown, has been obtained from records and cannot be guaranteed

accurate. The Contractor shall diligently check for interferences with existing utilities ahead of his or her work including exploration in advance of excavation.

The Contractor is further alerted to the provisions of RCW 19.122 and his or her responsibilities by performing excavation required by the Contract Documents and Standard Specifications.

Structure Excavation Class B Including Haul for the installation and/or removal of underground utilities, pipes, and structures shall be considered **incidental** to and included in the structure installed or removed.

7-08 GENERAL PIPE INSTALLATION

7-08.1 Description

(Special Provision)

Supplement

Material excavated shall not be used as backfill and shall be hauled away and wasted at the Contractor's expense.

Trench excavation shall be considered **incidental** to and included in the unit contract price for pipe. Bedding, backfill, and compaction will be paid under the Crushed Surfacing Top Course bid item, as 100% import is required for this project. Trench shall be excavated to a sufficient width to allow for pipe installation, compaction equipment, and shoring when necessary. Paving width shall be as shown on the City Standard Detail, W-3. No additional payment will be made for excavation and backfill of additional trench widths beyond the maximum trench width (nor for related quantities such as Crushed Surfacing Top Course, Hot Mix Asphalt (HMA) Class B Temporary Trench Patch, Hot Mix Asphalt (HMA) Class B Permanent Trench Patch) unless extra trench width has been specifically directed by the City Inspector.

Contractor shall pothole ahead of pipe-laying as outlined in Section 7-09.3(7) herein to make vertical adjustments as necessary to avoid existing utilities. Should the Contractor fail to pothole known utility crossings, any subsequent adjustments necessary shall not be cause for additional cost or time claim.

All construction shall conform to these Specifications, to the lines, limits and grades shown on the drawings and as designated by the Engineer. Backfill shall be compacted to 95% dry density. Line and grade shall be provided by the Contractor. City will contract for independent testing.

Trenches shall be backfilled to grade and paved with a temporary trench patch at least once per week. Backfilled trench surfaces shall be patched more if weather demands. Steel plates may be used only for pre-digging connections or when CDF is required for backfill. The edges of the plates shall be ramped with temporary hot mix asphalt to provide a smooth transition to the existing pavement.

7-08.2 Materials

(Special Provision)

Supplement

Aggregates for foundation material, pipe zone bedding, pipe zone backfill, and trench backfill shall meet the requirements of Section 9-03.9(3) "Crushed Surfacing" of the Standard Specifications.

The City shall provide compaction testing by others under a separate contract.

7-08.3 Construction Requirements

7-08.3(1)A Trenches

(Special Provision)

Supplement

All trenches within the roadway area shall be backfilled with 5/8" minus crushed surfacing top course material that meets the requirements of 9-03.9(3) of the Standard Specifications.

Backfilled trench surfaces shall be patched at the end of each week with a two (2) inch minimum compacted depth of temporary hot mix asphalt and maintained level with the existing grade until final surface restoration is completed. More frequent trench patching may be necessary if roadway surface conditions change and will be at the discretion of the City inspector. The trench surface shall be kept reasonably smooth, free from ruts and potholes, and suitable for normal traffic flow. Temporary trench patches must be continually maintained by the Contractor at his expense. Backfilled trench surfaces shall be patched daily if weather demands.

Continuing maintenance of temporary patching shall be incidental to the work and no additional payment shall be made.

7-08.3(1)B Shoring

(Special Provision)

Supplement

Shoring design shall be the responsibility of the Contractor. No implication of methods, means or materials is implied within the Plans.

7-08.3(1)C Bedding the Pipe

(Special Provision)

Supplement

If foundation material at the base of structure excavation is unsuitable, it shall be removed and replaced with compacted crushed surfacing top course. Care must be taken to hand tamp under mains, corporation stops and services.

Gravel backfill for pipe bedding indicated on the Plans shall be in accordance with Section 9-03.9(3) Crushed Surfacing of the Standard Specifications.

7-08.3(3) Backfilling

(Special Provision)

Supplement

Select trench backfill material shall be:

Crushed Surfacing Top Course

9-03.9(3)

All trenches shall be backfilled with select materials, except that recycled materials will not be allowed.

7-08.3(4) Plugging Existing Pipe

(Special Provision)

Supplement

Plugging existing utility pipe and structures shall be considered **incidental** to and included in the unit contract price of the various bid items in the contract. Existing utility pipes to be abandoned shall be capped or fully plugged on the inlet end with commercial concrete conforming to section 6-02 "Concrete Structures" of the standard specifications.

7-09 WATER MAINS

7-09.2 Materials

(Special Provision)

Supplement

Pipe and fittings larger than two (2) inches shall be of Ductile Iron construction, unless otherwise shown on the plans. Only domestic made ductile iron and steel materials are allowed.

Ductile Iron Pipe Fittings shall be per Section 9-30.2(2) of the Standard Specifications.

Valves two (2) inches and larger shall be Mueller or Kennedy valves meeting AWWA C-515 and AWWA C-509.

Replace the first sentence of paragraph 2 with the following: If requested by the Owner, the pipe manufacturer shall test all pipe and fittings as required by these Standard Specifications and the standards referenced.

Aggregates for foundation material, pipe zone bedding, pipe zone backfill, and trench backfill shall meet the requirements of Section 9-03.9(3) "Crushed Surfacing" of the Standard Specifications.

7-09.3(5) Grade and Alignment

(Special Provision)

Supplement

Replace the first sentence of the third paragraph with the following:

The depth of trenching for the water main shall be a minimum of 3 feet of cover for 8-inch or smaller water main unless superseded by graphically showing more or less cover in the plan and profile drawings. Additionally, the Contractor shall pothole in accordance with Section 7-09.3(7) such that grade changes can be made so that hydrants can be installed without using vertical bends on the hydrant run to cross existing utilities.

7-09.3(7) Trench Excavation

(Special Provision)

Supplement

Costs for trenching shall be incidental to other bid items. Trench shall be excavated to a sufficient width to allow for pipe installation, compaction equipment, and shoring when necessary. Pay width shall be as shown on the City Standard Detail. No additional payment will be made for excavation of trench widths beyond these pay limits (nor for related quantities such as Crushed Surfacing Top Course, Hot Mix Asphalt (HMA) Class B Temporary Trench Patch, Hot Mix Asphalt (HMA) Class B Permanent Trench Patch) unless extra trench width has been specifically directed by the City Inspector.

When proposed water mains, water services, or proposed fire hydrant laterals cross existing utilities and water mains, the Contractor shall pothole to locate the existing utilities. Potholing of existing utilities and water mains must be performed at a minimum 500 feet in advance of installing the proposed water main to maintain positive slope and three (3) feet minimum cover for 8-inch or smaller water main and (3.5) feet minimum cover for 12-inch water main. The City shall be given the pothole information to determine if a conflict exists. Failure to pothole at least 500 feet in advance of the proposed water main installation may result in the Contractor having to remove and reinstall the newly placed water main at his or her own expense. Potholing of existing utility mains along proposed water mains shall be paid per each. **Potholing of all services shall be incidental. Potholing for proposed fire hydrant lead utility crossings, air/vacs and blowoffs (main or services) shall be incidental to installation.**

Underground utilities are shown in the approximate location. There is no guarantee that all utility lines are shown, or that the depth, location, size and material is accurate. Existing water service lines shall be assumed to be un-locatable because they generally lack tracer wire. City staff will mark the service only to alert the Contractor of its presence. The Contractor shall exercise extreme caution when locating services. Services broken or damaged shall be repaired immediately. The Contractor shall uncover all indicated piping where crossing, interferences, or connections occur prior to trenching or excavation for any pipe or structures, to determine actual depth, locations, size and material. The Contractor shall make the appropriate provision for protection of said facilities. The Contractor shall notify One Call at 8-1-1 two business days in advance and arrange for field location of existing facilities before construction.

The contractor shall notify PSE 48 hours in advance of excavation on SE 40th St and 88th Ave SE for PSE's High-Profile Gas facility. The contractor shall notify Shorewood 48 hours in advance of excavation on SE 40th from Greenbriar Ln to 90th Ave SE, on 90th Ave SE from SE 40th to SE 37th St, on SE 37th St from 90th Ave SE to 88th Ave SE and on 88th Ave SE from SE 37th St to SE 36th St for Shorewood's transmission main.

Each pothole shall be milled and restored with hot mix asphalt to allow for safe passage by vehicles and pedestrians by the end of the working day.

7-09.3(10) Backfilling Trenches

(Special Provision)

Supplement

Backfilled trench surfaces shall be patched at the end of each week with a two (2) inch minimum compacted depth of temporary hot mix asphalt and maintained level with the existing grade until final surface restoration is completed. More frequent trench patching may be necessary if roadway surface conditions change and will be at the discretion of the City inspector. The trench surface shall be kept reasonably smooth, free from ruts and potholes, and suitable for normal traffic flow. Temporary trench patches must be continually maintained by the Contractor at his expense.

Continuing maintenance of patching shall be incidental to the work and no additional payment shall be made.

7-09.3(19)A Connection to Existing Mains

(Special Provision)

Supplement

No shutoff of mains will be permitted on Mondays, Fridays, overnight, over weekends, holidays, or the day before or after holidays, unless otherwise authorized by the Engineer. No more than 35 homes can be affected during a shutdown. Only one (1) shutdown will be scheduled per day, and no more than two (2) shutdowns per week.

The Contractor shall verify existing pipeline material, size, outside diameter, and location prior to starting connections to the existing water system. The City Inspector must inspect and approve all materials on hand at least one (1) week in advance of any water main connections.

The Contractor will conduct all work related to existing asbestos cement pipe in strict accordance with current WISHA safety regulations and provisions contained within WAC 296-62-077, and follow the current asbestos abandonment procedures and laws. All costs related to work in compliance with established rules and regulations shall be the responsibility of the Contractor. Removal of existing asbestos cement pipe from the ground, if required, will be permitted only after the proper permits are obtained from the Puget Sound Air Pollution Control Agency. The Contractor will be responsible for all associated fees and permits required for asbestos removal and disposal. The contractor shall provide work crews with proper protective clothing and equipment, or a licensed company and/or licensed supervisor for abatement.

All materials and equipment (including emergency equipment) necessary to expedite the tie-in shall be on hand prior to the shutdown of existing water service or main.

The Contractor shall replace at his expense any and all existing utilities or structures removed or damaged during construction which were to remain.

The City will notify affected residents in advance, perform the shutdown and recharge the water main.

7-09.3(19)B Maintaining Service

(Special Provision)

Supplement

The Contractor shall schedule, cause, and control all work which requires shutdown of the existing water system, fire line, and services to be performed and completed so that the shutdown is no longer than six (6) hours in duration. Whenever a shutdown exceeds six (6) hours in duration the Contractor shall provide temporary service. Water main shutdowns and fire service shutdowns shall be scheduled from 9:00 am to 3:00 pm, Tuesday to Thursday.

Shutdown of existing water lines and fire lines will be performed only by the City and upon request to the Engineer. Shutdown of service shall be planned in detail with appropriate scheduling of the work and coordination with the Engineer.

Individual water service users shall be notified one (1) week in advance of their service shutoff through postcards and notified one (1) day before shutoff with door hangers. The Contractor shall provide three (3) weeks' notice to the City when the water main shutdown is scheduled.

7-09.3(21) Concrete Thrust Blocking

(Special Provision)

Supplement

Bedding, blocking, encasement, or slope anchor concrete shall be mixed from materials acceptable to the Engineer and shall have a 30-day compressive strength of not less than 3,000 psi. The mix shall contain five (5) sacks of cement per cubic yard and shall be of such consistency that the slump is between one (1) and five (5) inches. All concrete shall be mechanically mixed. Blocks shall be left open for inspection. Polywrap is to be used on all bolt and fitting surfaces.

7-09.3(23) Hydrostatic Pressure Test

(Special Provision)

Revised Section

The first sentence of the first paragraph is deleted. Paragraphs 4, 5, 6, and 7 are deleted.

The following is added:

All water main connections and appurtenances shall be tested in sections of convenient length under a hydrostatic pressure equal to 250 psi. All pumps, gauges, plugs, saddles, corporation stops, miscellaneous hose and piping, and measuring equipment shall be furnished and operated by the Contractor.

The Contractor, except where otherwise permitted by the Engineer, shall test sections between valves individually. The Contractor shall furnish all labor, materials, and equipment necessary to make the tests, including pressure gauges. Water shall be obtained from the City of Mercer Island in accordance with Section 7-00.1 of these Technical Specifications.

At points where pressure reaction and movement may occur, such as bends, tees, and plugs, the pipe shall be properly blocked or braced. Where permanent blocking is not required, the contractor shall furnish and install temporary blocking and remove it after testing. All costs to Contractor for installing temporary blocking shall be included in the unit bid price for the water main connection.

The test pressure shall be applied at the low end of the section of water main being tested. Air in the pipe shall be vented at all high points.

The hydrostatic test pressure shall be maintained until the Engineer has determined that the section of pipe, valves, and fittings are watertight. If there are no visible leaks and zero water loss indicated by zero loss in pressure for fifteen (15) minutes the main will be accepted as a watertight installation. Defective materials or workmanship discovered as a result of hydrostatic field test shall be replaced by the Contractor at his expense.

Whenever it is necessary to replace defective material or correct the workmanship, the hydrostatic test shall be rerun at the Contractor's expense until a satisfactory test is obtained.

7-09.3(23)A Testing Extensions From Existing Main

(Special Provision)

Revised Section

This section is changed to be as follows:

Hydrants installed and connected by wet-tapping or hydrants that are merely reset shall be tested per Section 7-09.3(23)C of the Standard Specifications.

7-09.3(24)A Flushing

(Special Provision)

Revised Section

The last paragraph is changed to be as follows:

The Contractor shall secure a hydrant meter with approved backflow device from the City for obtaining water from the existing system during construction. A deposit of \$2,900 is required for the meter. All water used during construction must be obtained through the hydrant meter and backflow device. The hydrant meter and backflow device must be returned to the City at the end of the Project, after which the City will invoice the Contractor for water usage. Upon payment of the water charges, and after confirmation of no damage to the assembly, the City will return the full deposit to the Contractor.

Prior to placing new water main connections into service, the installed pipes shall be disinfected and flushed with City of Mercer Island water. A satisfactory test result shall be received by the City for the water samples collected after the flushing before the new main is allowed to be connected for service.

Disposal shall be to the sanitary sewer system at a rate of discharge approved by the Engineer. Precautions shall be taken to avoid back siphonage and/or contamination of the water system (maintain an air-gap between all water discharging to the sewer system). Coordinate with the City Inspector two (2) weeks in advance of flushing to monitor downstream sewer station.

7-09.3(24)D Dry Calcium Hypochlorite

(Special Provision)

Revised Section

“70%” is changed to “75%”.

7-09.3(24)N Final Flushing and Testing

(Special Provision)

Supplement

The following is added:

Ductile iron water pipe and fittings will not be accepted until the water in the pipe during acceptance tests remains free of deleterious tastes and odors. The Contractor shall, at his own expense, provide all necessary labor, equipment, and water for cleaning and flushing until pipe and fittings are acceptable. The Contractor shall, at his own expense, handle and dispose of flushing water in accordance with current regulations in a manner acceptable to the Engineer. Disposal of chlorinated water shall be to the sanitary sewer system at a rate of discharge approved by the Engineer. Precautions shall be taken to avoid back siphonage and/or contamination of the water system (maintain an air-gap between all water discharging to the sewer system). All flushing shall be discharged into the Sanitary Sewer.

7-09.3(25) Plugging Existing Water Main Pipe

(Special Provision)

New Section

All openings of water lines to be abandoned in place and plugged, shall be plugged, capped, and/or flanged with a mechanical ductile iron or steel plug, cap, or flange as indicated on the Plans. Concrete for plugging

pipes shall be Commercial Concrete conforming to Section 6-02 "Concrete Structures" of the Standard Specifications, and in accordance with the Standard Specifications Section 7-08.3(4).

7-12 VALVES FOR WATER MAINS

7-12.1 Description

(Special Provision)

Supplement

Adjusting Water Valves to Grade

Any settling of valve boxes shall be corrected by the Contractor by the end of the warranty period.

Adjusting newly installed water valve boxes to grade shall be **incidental** to the water main installation, water meter installation, air and vacuum assembly, blow off assembly, and/or fire hydrant assembly.

Air and Vacuum Assembly

Air and Vacuum Assemblies shall be constructed as shown on the plans and as indicated on the City of Mercer Island Standard Detail W-25.

7-12.3 Construction Requirements

(Special Provision)

Supplement

The following paragraphs are added:

Valves shall be installed so that the stems are vertical and centered in valve box, unless otherwise directed by the Engineer. Jointing shall conform to AWWA C600. Valves shall be installed in accordance with the details shown. Valves shall be tested with the adjacent pipeline. As specified herein, hydrostatic tests shall be conducted so as to limit the differential pressure across valves to 150 psi. If a valve joint leaks under test, the valve shall be disconnected and reconnected, and the valve and the pipeline re-tested. If valve leaks under test, valve shall be replaced and the new valve and the pipeline re-tested.

Backfill for valves and valve boxes shall be the same as specified for the adjacent pipe. Place backfill around the valve boxes and thoroughly compact to a density equal to that specified for the adjacent trench and in such manner, that will not damage or displace the valve box from proper alignment or grade.

Misaligned valve boxes shall be excavated, plumbed, backfilled and the valve and adjacent pipeline re-tested at the Contractor's expense. A minimum eight (8) inch overlap between the upper and lower valve boxes will be required to ensure the valve box height can be adjusted during future overlays.

When abandoning existing gate valves on a tee, the Contractor is to remove the valve and install a blind flange; if the tee is in poor quality the city may require the contractor to completely cut out the existing valve and replace with spool and sleeves. If the valve is on a section of water main that is being abandoned, the contractor shall close the existing valve and remove the valve box and lid to one (1) foot below grade. Replace the lid and add PVC marker that reads "Abandoned Gate Valve." Valves from the abandoned water mains shall be removed and return to City storage yard as salvage.

7-14 HYDRANTS

7-14.1 Description

(Special Provision)

Supplement

This work shall also consist of removing existing hydrants and installing new hydrants per the City of Mercer Island Standard Detail W-24.

7-14.2 Materials

(Special Provision)

Supplement

Pipe and Fittings

Unless otherwise indicated, all pipe and fittings shall be ductile iron in conformance with Sections 9-30.1(1) and 9-30.2(1) of the Standard Specifications, except that the thickness for other than restrained mechanical joint pipe shall be Standard Thickness Class 52. Pipe and fittings shall be double-thickness cement-mortar lined and seal coated with bituminous material conforming to ANSI A21.4 or AWWA C 104 and shall have exterior bituminous coating conforming to ANSI A21.4 or AWWA C 104. US Pipe Ductile Iron Tyton Pipe or approved equal will be accepted.

Pipe joints shall be push-on joints unless otherwise shown or required. The pipe manufacturer shall supply a sufficient quantity of a non-toxic vegetable soap lubricant for installing the pipe.

Mechanical joints shall conform to ANSI A21.11 or AWWA C111. Bolts for mechanical joints shall be Dresserloy or Cor-Ten high strength, low-alloy steel conforming to ASTM A242 and A558. Sigma Mechanical Joint Bolts or approved equal will be accepted.

Flanged joints shall conform to ANSI A21.10 or AWWA C110, or ANSI A21.12 or AWWA C115. Flanges shall be ductile iron. Gaskets for flanged joints shall be 1/8-inch thick, cloth-inserted rubber, conforming to applicable parts of ANSI B16.21 and AWWA C207. Gasket material shall be free from corrosive alkali or acid ingredients and suitable for use in potable water lines. Gaskets shall be one-piece, full-face with holes to pass bolts.

Mechanical joint long-pattern solid-sleeve cast iron fittings shall conform to ANSI A21.10 or AWWA C110. Solid sleeve minimum length shall be twelve (12) inches.

Restrained joints shall conform to Section 9-30.2(6) of the Standard Specifications. For special water main connections where blocking is not viable as determined by the Engineer, the Contractor may use mechanical joint restraints such as Romac Romagrip or approved equal. Coat all bolts and parts with coal tar epoxy.

Hydrants

Unless otherwise indicated on the plans, all hydrants shall be new. Hydrants shall conform to AWWA C502. Hydrants shall be break-flange or safety-top type. The inlet connection shall be mechanical joint. Nominal 5¼-inch compression type main valve opening with 6-inch bottom connections. Equip with two 2½-inch hose nozzles with American National Standard threads and one 4 ½ -inch pumper port, Storz Seattle style thread, model number HPHA 40-40-004/CAP, size 4.875-inch by 6-inch. Operating nut shall be 1½-inch National Standard Pentagon nut. The main valve shall be equipped with O-ring seals and shall open when turned counterclockwise. Acceptable hydrant models are Mueller Super Centurion or approved equal.

Installation of hydrants shall conform to the provisions of AWWA C600. Locate hydrants to provide complete accessibility and to minimize the possibility of damage from vehicles or injury to pedestrians. A minimum three (3) foot radius unobstructed working area shall be provided around all hydrants.

Set hydrants plumb and nozzles parallel with, or at right angles, to the curb or roadway, with the pumper nozzle facing the curb or roadway. Set hydrant so that the safety flange is two (2) inches above finished grade and bolts can be removed.

If the hydrant lead is longer than one full length of pipe Field Lok gaskets shall be used.

Place concrete block on firm, level sub-base to assure uniform support. Carefully place hydrant on base block to prevent the base block from breaking. Jointing procedures shall conform to AWWA C600. Strapping lugs shall not be used. After hydrant is in place and connected to the pipeline, place temporary blocks to maintain the hydrant in a plumb position during subsequent work.

Place 1-1/2" washed rock and filter fabric around base block and hydrant bottom after hydrant has been blocked in place. Top of the washed rock shall not be less than six (6) inches above hydrant drain opening.

After all installation and testing is complete, the exposed portion of the hydrant shall be thoroughly cleaned and painted with two coats of Farwest #250 high gloss white paint per City of Mercer Island Std. Detail W-24.

7-14.3(7) Removing Existing Hydrants

(Special Provision)

New Section

Existing hydrants to be removed on existing water mains that will remain active shall be removed to the hydrant tee at the existing main. A water main shutdown will be required for this work. The hydrant tee shall be capped or plugged and completed with a permanent blocking. If the hydrant valve is not flanged to the existing tee connection, then the tee shall be cut out and the contractor shall install spools and sleeves in place of the removed pipe and fittings.

The Contractor shall provide three (3) weeks' notice to the City when the water main shutdown is scheduled. The Contractor is to have both four (4) inch and six (6) inch flanged and mechanical joint caps and plugs onsite prior to shutting down the water system.

The City will notify affected residents in advance, conduct the shutdown and recharge the water main.

In situations when existing hydrants will be removed on existing water mains scheduled to be abandoned, the hydrant assembly shall be removed and the existing pipe capped or plugged as directed by the City. No water main shutdown will be required for this work.

7-15 SERVICE CONNECTIONS

7-15.1 General

(Special Provision)

Supplement

This work consists of installing new or existing water meters, constructing the new water services, reconnecting to the existing water service, and disconnecting and abandoning existing water service connections, all as shown on the Plans. If water meters are to be replaced, they will be provided by the City to the Contractor unless otherwise noted on the plans. Water meter boxes are to be provided by the City unless the existing box is to remain as noted in the water service table on the Plans.

7-15.2 Materials

(Special Provision)

Supplement

Materials

Water valve boxes shall be Olympic Foundry #VB940.

Materials for installation of new service connections shall conform to the following:

- Gate valves and valve boxes shall conform to Section 7-12.2 with insulated couplings.
- Brass fittings and copper pipe shall be used from the water main to the water meter.
- Brass fittings and nipples shall use TFE thread seal tape.
- The potable portion of the water system shall contain a maximum weighted average lead content of 0.25% in accordance with the Reduction of Lead in Drinking Water Act, effective January 4, 2014.
- Meter boxes shall be per City of Mercer Island Std. Detail W-18A.

All removed water meters, setters, valves, and other metal hardware removed from the job site should be returned to the City storage yard as salvage.

Valves

Gate valves shall be ductile iron (DI) body, bronze-mounted, double-disc, resilient seat, NRS valves with O-ring seals and shall open when the stem is rotated counterclockwise. Valves shall have two (2) inch square wrench nuts. Joint materials shall conform to AWWA C110. Valves shall be Mueller or Kennedy valves meeting AWWA C-515 and AWWA C-509.

Valve boxes shall consist of cast iron top section, cover, and lower section manufactured by Olympic Foundry, Inc. Seattle, Washington. The top section shall be Model VB2C and shall have an overall length of eighteen (18) inches. The cover shall be Model VB2A and shall have ears and the word WATER cast in the top. The lower section shall be Model VB1C and shall have a minimum length of twenty-four (24) inches. No other manufacturer's type will be approved.

Valves shall be installed so that the stems are vertical, unless otherwise directed by the Engineer. Jointing shall conform to AWWA C600. Valves shall be tested at the same time as the adjacent pipeline. Hydrostatic tests shall be conducted so as to limit the differential pressure across valves to 150 psi. If a valve joint leaks under test, the valve shall be disconnected and reconnected and the valve and the pipeline re-tested. If a valve leaks under test the valve shall be replaced and the new valve and pipeline re-tested.

Backfill for valve and valve boxes shall be the same as specified for the adjacent pipe. Place backfill around the valve boxes and thoroughly compact to a density equal to that specified for the adjacent trench and in such a manner that will not damage or displace the valve box from proper alignment or grade.

Misaligned valve boxes shall be excavated, plumbed, backfilled, and the valve and adjacent pipe retested at the Contractor's expense.

7-15.3 Construction Requirements

(Special Provision)

Supplement

Construction

The water main shall be tapped using a tapping machine by experienced workers using tools in good repair with proper adapters for the size of the main being tapped. Do not place any service tap within two (2) feet of a pipe joint or another service tap.

The minimum depth of cover to the installed water service connection shall be thirty (30) inches from the final surface. Backfill for the service connection shall be as specified for water lines.

Maintain existing services until the new service connections (completed up to the curb stop) are tested, disinfected and flushed. Upon satisfactory waterline testing and receipt of satisfactory lab report, complete the water meter installation and connection to the existing private service line. Where required, disconnect the existing service by turning off the corporation stop at the waterline connection. If PRVs are required, Contractor shall be responsible for adjusting individual PRVs after service connection has been completed. Pressures at the property shall be set after installation and calibration of PRVs on the main.

Backfill for disconnecting existing service shall be the same as specified for the new service.

Set meter boxes on firm compacted gravel backfill and adjust to finished grade. In traffic areas set meter box on concrete blocks that bear on compacted gravel. Meter dial must be centered under the reading lid. Boxes must be perpendicular to the street.

In cases where the existing water service is located across an adjacent property, the new service will be installed in front of the served property. The Contractor shall pothole and locate the customer side of the service within the served property. After locating, the Contractor shall hole hog a new customer side service line from this point to the back of the new location of the meter such that no part of the water service is located on an adjacent property.

One (1) inch services shall have a new one (1) inch setter, except for those specified in the water meter table on the Plans. For existing three-fourths ($\frac{3}{4}$) inch and five-eighths ($\frac{5}{8}$) inch services, the Contractor shall use a meter adapter to maintain the one (1) inch meter laying length, install existing meter, or a new meter provided by the City. For reconnecting at existing setter, all components within the meter box shall not be replaced.

One and one-half ($1\frac{1}{2}$) inch services shall have a new two (2) inch service line from the new water main and reconnect to the existing meter at the reducers (2 by $1\frac{1}{2}$ -inch) location per City of Mercer Island Std. Detail W-14. Two (2) inch services shall have a new two (2) inch service line from the new water main and reconnect to the existing meter per City of Mercer Island Std. Detail W-14A. All components within the meter box shall not be replaced.

All services saddles tapped from existing water main shall use a Romac double strap stainless steel saddle or approved equal.

While trench details for water services show open cuts, the City will allow long services to be bored if the Contractor chooses to do so. If the Contractor elects to bore long side water services the Contractor will be required to pothole prior to boring. All other provisions of the specifications shall apply and no additional payment will be made beyond the unit price bid for the respective water service. Contractor shall verify all existing utility locations and repair any damaged utilities at their expense.

**DIVISION 8
MISCELLANEOUS CONSTRUCTION**

8-01 EROSION CONTROL AND WATER POLLUTION CONTROL

8-01.1 Description

(Special Provision)

Supplement

The Contractor shall install and maintain all temporary and permanent erosion control measures and Best Management Practices (BMP's) in accordance with the Plans, Standard Specifications, Technical Specifications, permit conditions, or as directed by the Engineer prior to clearing, grubbing, or grading or as necessary as clearing and grading progress. Such measures shall include, but are not necessarily limited to:

- Erosion and water pollution control for stockpiled materials
- Straw bale check dams
- Straw mulch, netting, and tackifier
- Temporary construction entrance/exit
- Inlet protection on existing and proposed drainage structures
- Reinforced silt fencing
- Plastic covering
- Temporary HMA thickened edge
- Disposal of sediments and materials
- Maintenance of BMPs including in the event of emergencies and as weather and field conditions dictate; and also including installation of additional BMPs which may become required as field and weather conditions evolve.
- Street sweeping and cleaning
- All materials, tools, and equipment necessary to meet these requirements

All disturbed areas shall be hydroseeded except as are designated to be planted. The seeding may be accomplished by approved hand methods when impractical to perform by hydroseeding. The Contractor shall submit the proposed plan for hand seeding to the Engineer for approval five days prior to any seeding.

All sawcutting residue and slurry must be vacuumed immediately behind the sawcut wheel. No sawcut residue shall enter storm drain fixtures.

Water

The Contractor shall make, at the Contractor's expense, whatever arrangements may be necessary to ensure an adequate supply of water required for erosion control. The Contractor shall also furnish all necessary hose, equipment, attachments, and accessories for the adequate irrigation of planted areas as may be required to complete the work as specified.

8-01.3 Construction Requirements

8-01.3(2)

(Special Provision)

Supplement

8-01.3(2)A Preparation for Application

(Special Provision)

Supplement

8-01.3(2)A1 Seeding

(Special Provision)

New Section

All disturbed areas, which are not otherwise restored, shall be seeded. All areas to be seeded shall be raked or similarly treated so as to provide a smooth, consistent, friable surface, acceptable for seeding as determined by the Engineer.

All areas to be seeded shall be free of all visible clods, rocks, and debris measuring one (1) inch or larger in any dimension. Any exposed tree roots in cut slopes shall be cut neatly and protected, as detailed on the Plans. All costs involved in the seed bed preparation shall be included in the force account price for Property and Landscape Restoration.

8-01.3(2)B Temporary Seeding

(Special Provision)

Supplement

Seeding

Where feasible, the hydroseeding method of application shall be used. A slurry consisting of seed, fertilizer, mulch and water shall be uniformly applied over all unpaved disturbed areas, except planter areas per Plans, within easements and right of way unless directed otherwise. Seed shall be applied at a rate per Section 9-14.2 Seed, of these Technical Specifications.

Hand Seeding

Seed shall be applied at the rate of six (6) pounds per one thousand (1,000) square feet. The seed shall be applied by an approved hand-held spreader. The seed shall be evenly distributed over the disturbed area. Apply seed after the fertilizer has been accomplished and rake the seed into the surface of the soil to a depth of one-fourth ($\frac{1}{4}$) inch.

Fertilizing

Fertilizer shall be applied at the rates specified per Section 9-14.3 "Fertilizer", of these Technical Specifications. Fertilizer shall be incorporated into the seed, mulch, and water slurry and shall be applied as specified under Seeding.

Liming

Agricultural lime shall be applied to all hydroseeded areas at the rate of one hundred (100) pounds per one thousand (1,000) square feet.

Hand Fertilizing

Fertilizer shall be applied at the rate of ten (10) pounds per one thousand (1,000) square feet. The fertilizer shall be applied by an approved hand or mechanical method. It shall be raked into the surface soil to a depth of one (1) inch.

8-01.3(2)D Temporary Mulching

(Special Provision)

Supplement

Mulch shall be applied at the rate of two thousand (2,000) pounds per acre. The Contractor shall follow the manufacturer's recommended quantities of mulch in pounds to the tank capacity in gallons. One thousand (1,000) pounds of mulch shall be included in the slurry of seed, fertilizer and water and applied to the areas to be seeded. The remaining one thousand (1,000) pounds of mulch shall be applied in a separate operation immediately following the first application. The force account price for Property and Landscape Restoration shall include two separate applications as specified and no further compensation made.

Hand Mulching

Straw shall be transported to the location site in bales for distribution. Bales shall be broken and the loose straw evenly spread over the hand seeded and fertilized areas to a depth of two (2) inches. Straw mulch shall be placed prior to any netting or tackifier. Each bale shall cover an area not to exceed one hundred (100) square feet.

8-01.3(8) Street Cleaning

(Special Provision)

Supplement

The Contractor shall be responsible for controlling dust, sawcutting residue, and mud within the project. The Contractor shall be prepared to use watering trucks equipped with high-velocity water jets and low-head sprinkling devices, power sweepers, and any other pieces of equipment necessary to avoid creating a nuisance. All streets used by the Contractor during the execution of the work under this contract shall be maintained in a clean condition. Any damage caused by dust and/or mud shall be the sole responsibility of the Contractor. In no case shall sediment-laden water be allowed to enter drainage facilities without prior filtration or sedimentation.

The roadway shall be swept daily and as needed. Flushing will not be permitted.

8-01.3(9)D Inlet Protection

(Special Provision)

Supplement

Inlet protection can be in the form of internal devices and shall be installed prior to clearing, grubbing or earthwork activities. Catch Basin inserts shall be installed on all existing and new catch basins that are located within the project.

When the depth of accumulated sediment and debris reaches approximately one-half (1/2) the height of an internal device or one-third (1/3) the height of the external device (or less if so specified by the manufacturers), the deposits shall be removed and stabilized on site.

Catch Basin Inserts

Catch basin inserts shall be installed at all catch basins within project limits and those immediately downstream of the project site that could possibly receive sediment laden runoff from the site. They shall be installed and meet the requirement of the detail in the Plans. Simply placing a piece of geotextile under the catch basin grate is not acceptable.

Catch basin inserts shall be installed, maintained, inspected, and removed per the Standard Specifications and as recommended by the manufacturer. Pre-approved manufactured products include:

- Siltsack by Atlantic Construction Fabrics, Inc. (800) 448-3636
- StreamGuard by Foss Environmental, (800) 909-3677

- Emcom Insert by Emcom NW, (425) 462-1280
- Beaver Dam or Dandy Bag by Dandy Products Inc., (800) 591-2284
- Envirodrain
- Drain Warden, or
- Approved Equal

8-01.3(16) Removal

(Special Provision)

Supplement

Removing Temporary Erosion / Water Pollution Control BMPs

The Contractor shall remove all Temporary Erosion / Water Pollution Control BMPs within twenty (20) days after final slope stabilization, landscape restoration, or after the BMPs are no longer needed. Trapped sediment shall be removed or stabilized on site.

8-01.3(17) Suspension of Work

(Special Provision)

New Section

If at any time during the life of this Contract it becomes necessary, or the Contractor elects to suspend work due to weather conditions, material delivery schedules, or other constraints, it shall be the Contractor's obligation to meet the following requirements:

- The Contractor shall remain obligated to meet the Temporary Water Pollution / Erosion Control requirements of the Plans during any suspension of work.
- The Contractor shall remain obligated to meet the Temporary Traffic Control (both vehicular and pedestrian) requirements of the Plans during any suspension of work.
- The Contractor shall maintain vigilance and maintain a safe project area free of hazards to public safety and shall remedy all hazardous situations immediately.

8-02 ROADSIDE RESTORATION

8-02.1 Description

(Special Provision)

Supplement

All plant materials required by the Plans shall be plant species including plant establishment (PSIPE) per the Standard Specifications.

8-02.2 Materials

(Special Provision)

Supplement

Refer to Section 9-14 "Erosion Control and Roadside Planting" of these Technical Specifications.

8-02.3(1) Responsibility During Construction

(Special Provision)

Supplement

The Contractor shall locate all underground utilities (both new and existing) prior to starting work and shall not disturb or damage them. The Contractor shall promptly notify the Engineer of any conflict between the

proposed work and the obstructions. The Contractor shall be responsible for making any and all repairs for damage, at his own expense.

No flushing will be allowed. At the conclusion of the landscape construction, the Contractor shall remove surplus plant materials and installation debris from the construction site. The project shall be left in a condition acceptable to the Engineer.

8-02.3(3)A Chemical Pesticides

(Special Provision)

Supplement

No chemical herbicides will be allowed in any planting areas.

8-02.3(4)A Topsoil Type A

(Special Provision)

Supplement

Topsoil Type A shall conform to Section 9-14.1(1) "Topsoil Type A" of the Technical Specifications and shall be supplied by the Contractor's approved source.

Remove all construction debris prior to placing topsoil.

Subgrade will require review and approval by the Engineer prior to the placement of topsoil. The Contractor shall submit material certification for Topsoil Type A to the Project Engineer for approval before utilizing on site.

Thoroughly scarify subgrade in tree, shrub, and ground cover areas to a minimum depth of six (6) inches. Scarified subgrade shall be inspected and approved by the Engineer prior to placement of topsoil. Remove all construction debris and rocks over one (1) inch in diameter prior to the placement of topsoil.

Upon approval of the subgrade by Engineer, place Topsoil Type A to depth as indicated and shown on the Plans. Topsoil Type A shall be used in areas indicated for planting as shown on the Plans. Topsoil and subgrade material shall be cultivated to a depth of twelve (12) inches except in tree grate pits. Remove rocks, roots, and debris over one (1) inch in diameter. Lightly compact soil and establish a smooth and uniform finished grade that protects against obstruction to surface drainage and ponding. Materials shall be placed so that after settlement of finished grades the top of the root zone will be flush with the top of sidewalks in lawn areas. For bark mulch areas, finished grade prior to placement of bark shall be one (1) inch below top of sidewalk.

8-02.3(5) Roadside Seeding, Lawn and Planting Area Preparation

(Special Provision)

Supplement

The costs of removing all excess material and debris shall be included in the force account price for Property and Landscape Restoration.

Preparation for Topsoil Installation

After all planting and seeding areas have been brought to required subgrade, the areas shall be reviewed and approved by the Engineer. Prior to topsoil installation, they shall be cultivated to a depth of six (6) inches unless otherwise specified. Cultivation of the soil shall be done by farm disk, harrow, or other suitable equipment approved by the Engineer. This operation should be done at right angles to the natural flow of water on slopes unless otherwise directed by the Engineer. All costs and expense incurred in performing the specified work shall be included in the force account price for Property and Landscape Restoration.

Remove all visible rocks, clods, stumps, and debris one (1) inch or larger in any dimension. Any exposed tree roots in cut slopes shall be neatly pruned at the finish subgrade and the cuts treated with an approved sealer.

Placement of Topsoil

Topsoil Type A shall be installed to a minimum six (6) inch compacted depth in all shrub and groundcover areas and as required to bring disturbed areas to finished grade. All hydroseeded areas shall receive minimum two (2) inch depth of Topsoil Type A, or as required to bring subgrade to finished grade. Swale seeded areas shall receive compost incorporated into the subgrade as noted on the plans, no topsoil is required.

Finish Grading of Topsoil

Finish grade all topsoil areas removing all rocks, sticks, and other debris one-half (1/2) inch or larger in any dimension from the topsoil surface. Rake, float, drag, roll, and perform all necessary operations to produce a firm, smooth surface without depressions and with positive drainage. Finish grades of topsoil shall be one (1) inch, or the specified depth of mulch, below walks, curbs, tops of walls, valve and junction boxes, and driveways, unless otherwise shown on plans or specified. Finish grades shall be reviewed and approved by the Engineer prior to any planting or seeding.

8-02.3(7) Layout of Planting

(Special Provision)

Supplement

The Contractor shall layout plantings as directed by the Engineer.

The Contractor shall place groundcover plantings starting from the perimeter of the planting area and progress to the center. Field adjustments for plant layout shall be approved by the Engineer.

8-02.3(10) Fertilizers

(Special Provision)

Supplement

Fertilizers shall be approved by the Engineer. Trees and shrubs shall be fertilized at a rate of nine (9) tablets per tree, three (3) tablets per 5-gallon shrub or one (1) tablet per 1-gallon shrub or groundcover. Fertilizer tablets (or Paks) shall be considered included in the project and no additional compensation will be made.

8-02.3(11)B Bark or Wood Chip Mulch

(Special Provision)

Supplement

Weed-free Bark Mulch shall be placed over all planting beds to a depth no less than three (3) inches. Bark Mulch shall be placed in a minimum five (5) foot diameter around trees with a one (1) inch gap between the trunk/stem and mulch such that mulch is not in direct contact with the planting. The City may require greater diameter for large-caliper trees. Thoroughly water and hose down plants with a fine spray to wash the leaves of the plants immediately after application.

8-02.3(17) Property Restoration

(Special Provision)

New Section

Roadside planting for property and landscape restoration shall consist of fine grading adjacent landscaped areas, placement of additional plant materials, extra seeding or bark mulch, slope restorations, irrigation system repair or replacement, and all other work not currently identified on the Plans, as directed by the Engineer.

The Contractor is specifically reminded that unnecessary damage caused beyond the limits of clearing or construction shall be repaired in like or better condition at the Contractor's sole expense.

8-03 IRRIGATION SYSTEMS

8-03.3 Construction Requirements

(Special Provision)

Supplement

All work shall be in strict conformance with the City of Mercer Island Water Standards, together with the Plans, details and manufacturer's written information regarding recommended installation procedures.

Private irrigation systems that have been damaged during construction activities shall be repaired or replaced within five (5) working days. The Contractor shall be liable for any damage due to irrigation facilities damaged by his operations and shall repair such damaged facilities to an "equal or better than" original condition. This work will include, but not be limited to, cutting and capping existing pipe, relocating existing risers and sprinkler heads, new pipe heads and connections, and testing of the system.

Prior to disturbance of any irrigation system the Contractor shall make arrangements with the property owner to have the existing system turned on and tested. Deficiencies found shall be reported to the Engineer prior to disturbance of the existing system.

Existing systems shall be retested after modifications have been made in the presence of the Engineer. The Engineer must approve the private irrigation system modification prior to acceptance of the work.

8-04 CURBS, GUTTERS, AND SPILLWAYS

8-04.3(1) Cement Concrete Curbs, Gutters, Spillways

(Special Provision)

Supplement

Concrete finish to be determined by City Inspector.

8-13 MONUMENTS

8-13.3 Construction Requirements

(Special Provision)

Revised Section

Any monuments disturbed during Construction shall be reset by the Contractor. The Contractor is responsible for notifying the Surveyor prior to disturbing any monuments so that the proper survey ties and paperwork can be completed prior to disturbance.

8-14 CEMENT CONCRETE SIDEWALKS

8-14.3(3) Placing and Finishing Concrete

(Special Provision)

Supplement

Concrete finish to be determined by City Engineer.

**DIVISION 9
MATERIALS**

9-14 EROSION CONTROL AND ROADSIDE PLANTING

The materials for Property and Landscape Restoration shall meet the requirements of Section 9-14 of the Standard Specifications supplemented as follows. Irrigation water shall conform to the provisions of Section 9-25.2 of the Standard Specifications.

9-14.1 Topsoil

9-14.1(1) Topsoil, Type A

(Special Provision)

Supplement

Topsoil Type A shall be two-way soil mix or approved equal, with the following specifications:

Soil mix shall be a mixture of pure compost, and sand, sandy loam or silty sand. The soil shall be high in organic content and comprised of fully composted and mature organic materials. No fresh sawdust or other fresh wood by-products shall be added to extend the volume after the composting process.

Compost shall be ninety-eight percent (98%) minimum material derived from the aerobic decomposition of recycled plant waste and/or secondary sewage treatment. It shall be free of viable weed seeds and other plant propagules and shall have a moisture content that has no visible free water or dust produced when handling the material.

Chemical/physical characteristics shall comply with the following:

Screen Size (approx. particle size)	7/16" maximum
Total Nitrogen	.25% minimum
Organic Matter	10% minimum
pH Range	5.5-7.5
Conductivity	5 mmhos/cm maximum

The following are acceptable sources/products for Topsoil:

Pacific Topsoil Environmental Mix, Cedar Grove 2 Way Mix, or approved equal.

9-14.2 Seed

(Special Provision)

Supplement

Non-Residential lawns, pastures, and vacant land may be restored with Hydroseed meeting the following requirements:

Hydroseed Mix #1 (Master Lawn Mix) as follows, available from Grass Master, Redmond, WA (425) 867-1117, or approved equal:

<u>Common Name</u>	<u>Volume Percentage</u>
Chewing Fescue	20%
Hard Fescue	10%
Perennial Rye Grass (3 different varieties)	70%

9-30 WATER DISTRIBUTION MATERIALS

9-30.2(2) Ductile Iron Fittings

(Special Provision)

New Section

Unless otherwise shown, all pipe and fittings shall be ductile iron in conformance with Sections 9-30.1(1) and 9-30.2(1) of the Standard Specifications, except that thickness class for other than restrained mechanical joint pipe shall be standard thickness class 52 minimum. Pipe and fittings shall be double-thickness cement-mortar lined and seal coated with bituminous material in accordance with ANSI A21.4/AWWA C104 and shall have exterior bituminous coating conforming to ANSI A21.4/AWWA C104.

Pipe joints shall be push-on joints unless otherwise shown or required. A nontoxic vegetable soap lubricant shall be supplied by the pipe manufacturer in sufficient quantities for installing the pipe.

Fitting joints shall be as shown. Mechanical joints shall conform to ANSI A21.11 or AWWA C111. Bolts for mechanical joints shall be Dresserloy or Cor-Ten high-strength, low-alloy steel conforming to ASTM A242 and A558.

Flanged joints shall conform to ANSI A21.10/AWWA C110 or ANSI A21.15/AWWA C115. Flanges shall be ductile iron. Gaskets for flanged joints shall be 1/8-inch thick, cloth-inserted rubber, conforming to applicable parts of ANSI B16.21 and AWWA C207. Gasket material shall be free from corrosive alkali or acid ingredients and suitable for use in potable water lines. Gaskets shall be one-piece, full-face, with holes to pass bolts.

Water main connections shall use Romac couplings or approved equal when joining new ductile iron water main to existing PVC or asbestos cement water main.

9-30.3(1) Gate Valves (3 Inches to 16 Inches)

(Special Provision)

Supplement

Replace this section in its entirety.

Gate valves shall be ductile iron (DI) body, bronze-mounted, double-disc, resilient seat, NRS valves with O-ring seals and shall open when the stem is rotated counterclockwise. Valves shall have two (2) inch square wrench nuts. Joint materials shall conform to AWWA C110. Valves shall be Mueller or Kennedy valves meeting AWWA C-515 and AWWA C-509.

9-30.3(4) Valve Boxes

(Special Provision)

Revised Section

Valve boxes shall consist of cast iron top section, cover, and lower section manufactured by Olympic Foundry, Inc., Seattle, Washington. The top section shall be Model VB2C and shall have an overall length of 18 inches. The cover shall be Model VB2A and shall have ears and the word WATER cast in the top. The lower section shall be Model VB1C and shall have a minimum length of twenty-four (24) inches. No other manufacturer's type will be approved.

9-30.3(6) Valve Stem Extensions

(Special Provision)

Supplement

Refer to City Standard Detail W-9 for additional requirements.

9-30.3(7) Combination Air Release/Vacuum Valves

(Special Provision)

Supplement

The air and vacuum release valve assembly shall be constructed to permit the escape of large volumes of air when the waterline is being filled with water so that small amounts of accumulated air will be released under normal operating conditions, and so that air may re-enter the waterline to break any vacuum caused by water suction. The valve shall be designed to operate under working pressure not less than 150 psi and shall have been tested at a pressure not less than 300 psi. Provide test certification if requested by the Engineer.

The air and vacuum release valve shall be a one (1) inch combination air and vacuum release valve assembly, Val Matic 201C.2 or approved equal. The inlet and outlet shall have iron pipe threads.

Refer to City Standard Detail W-25 for additional requirements.

9-30.6(1) Saddles

(Special Provision)

Revised Section

Replace this section in its entirety. Refer to City Standard Detail W-13.

9-30.6(5) Meter Setters

(Special Provision)

Revised Section

Replace this section in its entirety. Refer to City Standard Details W-13, W-14 and W-14A.

DIVISION 10 MEASUREMENT AND PAYMENT

MEASUREMENT AND PAYMENT (Additional Section)

It is the intention of these specifications that the performance of all work under the bid for each item shall result in the complete construction in an accepted operating condition, of each item.

Work and material not specifically listed in the proposal, but required according to the contract plans, specifications, and general practice shall be included in the contractor's bid price. No separate payment of any kind will be made for these incidental items.

The Contract Price shall constitute full compensation for furnishing all plans, labor, equipment, incidentals and materials, applicable sales tax for materials and equipment, and performing all operations required to complete the work, as specified, as shown on the Contract Plans or as otherwise directed. Notwithstanding the omission or mention of any incidental work, the Contract Price and payment shall also constitute full compensation for all work incident or incidental to completion of the item, unless such work is otherwise specifically mentioned for separate payment under another bid item. In the event any work is required by the Specifications or by the Proposal, or which is not directly incident or incidental to the completion of any such item, the Contract Price of all enumerated items shall also constitute full compensation for such work.

Unless a specific bid item for the following work has been provided in the Proposal/Construction Contract, or the work has been specifically included in a bid item, such work shall be considered incidental to and included in the various bid items of work:

- Furnishing Manufacturer's Certificates of Compliance
- Clearing and grubbing
- Removal of structures and obstructions
- Roadway excavation including haul for water main and services trenching
- Protection of existing trees to remain
- Securing a disposal site and disposal of waste materials
- Haul
- Sawcutting and slurry vacuuming
- Milling or saw cutting pavement, except for planing prior to overlay.
- Watering
- Dust control
- Trimming and cleanup
- Construction Staking
- Pre-construction photographs
- Street cleaning

No separate or extra payment of any kind shall be made for this work under the Contract.

Minor Change

The force account for "Minor Change" shall include all work as described in Division 1-04.4(1) in the Standard Specifications. Measurement and payment shall be on a force account basis.

Record Drawings (Minimum Bid \$500.00)

The lump sum price for “Record Drawings” will be made on a prorated monthly basis for work completed in accordance with Section 1-05.18 up to 75% of the lump sum bid. The final 25% of the lump sum item will be paid upon submittal and approval of the completed Record Drawings set prepared in conformance with these Technical Specifications.

A minimum bid amount has been entered in the Bid Proposal for this item. The Contractor must bid at least that amount.

Mobilization (7% Maximum)

The lump sum price for “Mobilization (7% Maximum)” shall cover the complete cost of providing, furnishing, and installing all work and materials necessary to move or organize equipment and personnel onto the site, provide and maintain support facilities, obtain all necessary permits, licenses, and bonds. This bid item is not to exceed seven percent (7%) of total bid.

Demobilization (3% Maximum)

The lump sum price for “Demobilization (3% Maximum)” shall cover the complete cost of dressing and trimming the project area after construction of improvements and moving all personnel and equipment off the site after contract completion. This bid item is not to exceed three percent (3%) of total bid.

Shoring and Trench Safety Systems

The lump sum price for “Shoring and Trench Safety Systems” shall cover the complete cost of furnishing, installing and removing all sheeting, shoring, cribbing and coffer dams necessary to support the trench and excavation walls as specified in the contracts documents and as necessary for the proposed utility work. Partial payments for this bid item will be based on the percentage of main line installed.

Flaggers and Spotters

The contract unit price per hour for “Flaggers and Spotters” shall be measured and paid according to WSDOT Standard Specifications 1-10.4(2) and 1-10.5(2). A Traffic Control Supervisor that is acting as a flagger shall be paid for under this bid item, all other work activities done by the Traffic Control Supervisor will be incidental to the bid item Other Temporary Traffic Control.

Other Temporary Traffic Control

The lump sum price for “Other Temporary Traffic Control” shall be measured and paid according to WSDOT Standard Specifications 1-10.4(2) and 1-10.5(2).

The Contractor is reminded that specifically included in the price bid for Other Temporary Traffic Control are all costs for:

- Furnishing, installing, maintaining and removing traffic control, construction warning and detour signs
- Removing, salvaging, relocating and re-installing existing roadway signs
- Furnishing, installing, maintaining and removing traffic cones, barrels, barricades and the like
- Furnishing, installing, maintaining and removing steel plating, pins, shims and incidentals
- Prepare, revise and implement any traffic control/detour plans required per the Right-of-Way Use permit or the Right-of-Way Use Official. **This includes submitting for a permit to review the traffic control plans.** Permit fee for the Right-of-Way Use Permit will be paid for by the City, not the Contractor.

Potholing

The unit price per each of “Potholing” shall constitute compensation for all costs associated with hydro excavating existing utility mains as shown on the potholing plan. Hydro excavating of utility services for hydrant crossings, air/vacs and blowoffs (existing mains or services) are incidental to other bid items.

Crushed Surfacing Top Course

The unit price per ton of “Crushed Surfacing Top Course” shall be full compensation for furnishing, hauling, placing and compacting 5/8” minus crushed rock pavement base, rock used for concrete replacement areas, pipe bedding and imported backfill per Plans and Specifications. The price shall include all necessary grading of road base, installation and compaction of the crushed rock as a road base, gravel shoulder or driveway dressing, or as pipe and structure bedding and imported backfill. Measurement and payment shall be per ton of crushed rock in place based on actual truck weight tickets. The quantity shown for this bid item in the Bid Schedule is estimated and may vary. This bid item is not subject to price adjustments should the actual quantity used be higher or lower than the quantity estimated in the bid. No additional payment shall be made for removing, hauling and disposing of unsuitable materials which the Crushed Surfacing Top Course is replacing.

Certified tickets shall be furnished with each load of material delivered. No payment will be made without a ticket.

Hot Mix Asphalt (HMA) Class B Temporary Trench Patch

The unit price per ton of “Hot Mix Asphalt (HMA) Class B Temporary Trench Patch” shall be full compensation for all labor, equipment, tools and materials required to furnish and place 2-inch depth, Class B hot mix asphalt for temporary trench patching in roadways and driveways. The unit price shall include all necessary preparation, installation, compaction, and ongoing maintenance of the temporary Class B hot mix asphalt patch. Measurement and payment shall be per ton of temporary hot mix asphalt placed based on actual truck weight tickets.

The limits of the Hot Mix Asphalt Class B Temporary Trench Patch will be along the water main, services and appurtenances alignments at the maximum widths specified in the “Trench Section” detail included in the plans. Temporary trench patch shall only be paid once for each given trench area. If temporary trench patch is removed and replaced during construction, no additional payment will be paid for the removed portion.

If grindings are used as temporary patch, they will not be counted for payment as temporary trench patch.

Hot Mix Asphalt (HMA) Class B Permanent Trench Patch

The unit price per ton of “Hot Mix Asphalt (HMA) Class B Permanent Trench Patch” shall be full compensation for all labor, equipment, tools and materials required to furnish and place Class B hot mix asphalt pavement in 2-inch lifts for permanent trench patching in roadways and driveways. The unit price shall include all necessary pavement grinding, sawcutting, preparation of edges with asphalt emulsion, removal and disposal of temporary patching, base preparation, installation and compaction of the Class B hot mix asphalt and sealing of joints. **Replacement of existing and/or construction of new asphalt drainage berms and thickened edges shall be paid under this item.** Measurement and payment shall be per ton of hot mix asphalt placed based on actual truck weight tickets.

The limits of the Hot Mix Asphalt (HMA) Class B Permanent Trench Patch will be along the water main, services and appurtenances alignments at the maximum widths specified in the “Trench Section” detail included in the plans. Construction related damages to pavement outside of these limits will be repaired by the Contractor at the Contractor’s expense.

Asphalt Cost Price Adjustment

The Contracting Agency will make an Asphalt Cost Price Adjustment, either a credit or a payment, for qualifying changes in the reference cost of asphalt binder. The adjustment will be applied to

payments made according to Section 1-09.9 for Hot Mix Asphalt (HMA) Class B Temporary Trench Patch and Hot Mix Asphalt (HMA) Class B Permanent Trench Patchpartial.

The adjustment is not a guarantee of full compensation for changes in the cost of asphalt binder. The Contracting Agency does not guarantee that asphalt binder will be available at the reference cost.

The Contracting Agency will establish asphalt binder reference costs twice each month and post the information on the Agency website at: <https://wsdot.wa.gov/business-wsdot/how-do-business-us/public-works-contracts/payments-reporting/asphalt-binder-reference-cost>. The reference cost will be determined using posted prices furnished by Poten & Partners, Inc. If the selected price source ceases to be available for any reason, then the Contracting Agency will select a substitute price source to establish the reference cost.

Price adjustments will be calculated one time per month. No price adjustment will be made if the Current Reference Cost is within +/-5% of the Base Cost. Reference costs for projects located in Eastern versus Western Washington shall be selected from the column in the WSDOT website table labeled "Eastern", or "Western", accordingly. The adjustment will be calculated as follows:

If the reference cost is greater than or equal to 105% of the base cost, then
Asphalt Cost Price Adjustment = (Current Reference Cost – (1.05 x Base Cost)) x (Q x 0.056).

If the reference cost is less than or equal to 95% of the base cost, then
Asphalt Cost Price Adjustment = (Current Reference Cost – (0.95 x Base Cost)) x (Q x 0.056).

Where: **Current Reference Cost** is selected from the website table based on the "Date Effective" that immediately precedes the current month's progress estimate end date. For work completed after all authorized working days are used, the adjustment will be based on the posted reference cost during which contract time was exhausted.

Base Cost is selected from the website table based on the "Date Effective" that immediately precedes the contract bid opening date, and shall be a constant for all monthly adjustments.

Q = total tons of all classes of HMA paid in the current month's progress payment.

For the purpose of providing a common proposal for all bidders, the Contracting Agency has entered an amount in the proposal to become a part of the total bid by the Contractor.

XX-inch D.I. Class 52 Water Main

No measurement shall be made for clearing and grubbing, removal of existing street pavement, removal of in-place abandoned piping, protection of existing utilities and services, or trench excavation. When listed as separate pay items, other work shall be measured in accordance with the Standard Specification as modified by these specifications.

The Contract Price per linear foot for installing water pipe of the size, type and class specified shall constitute full compensation for all labor, materials and equipment required for:

- Sawcutting
- Milling, except for planing prior to overlay
- Excavating trench
- Compacting subgrade to provide firm base for pipe installation

- Removing and disposing of pavement, curbs, gutters, sidewalks and the like
- Trench dewatering (if needed)
- Hauling and disposing of surplus and unsuitable excavated material
- Removing and disposing of existing abandoned utilities which are in conflict with new water pipe
- Furnishing and installing water pipe, and all incidentals
- Ductile iron fittings shown on the Plans
- Potholing existing service crossings
- Deflecting pipe as required to cross over or under buried utilities including temporarily supporting the existing pipe
- Ethafoam as required between crossing utilities
- Plugging any cut or abandoned pipes
- Furnishing and installing concrete blocking and/or Romagrip-type restraints
- Installing all blocking per plans
- Testing water mains
- Disinfecting and flushing water mains
- Replacing, protecting and/or maintaining utilities
- All complete in-place, fully operational and ready for use

Furnishing imported pipe bedding and imported trench backfill will be paid for under the specific items set forth in the Proposal/Construction Contract.

Pipe required for Fire Hydrants Assemblies and Water Services, and all pipe required for Connections to the existing Water Mains shall be incidental to those bid items and not paid on a per foot basis. Backfill compaction tests will be performed at the City's expense under a separate contract.

Joint Restraints – Locking Gaskets

The unit price per each for “Joint Restraints – Locking Gaskets” shall constitute full payment for all costs associated with furnishing and installing locking gaskets along mainline pipe, where indicated on the plans. Joint restraints used at fire hydrant leads will not be paid for under this item and are considered incidental to fire hydrant bid item. Mechanical joint restraints shall be incidental to the bid item XX-Inch D.I. Class 52 Water Main.

Additional D.I. Fittings

Ductile iron fittings shown on the Plans shall be considered incidental to the bid item for “XX-inch D.I. Class 52 Water Main”. Measurement and payment for “Additional D.I. Fittings” shall include supplementary ductile iron fittings determined necessary during the course of construction, as approved by the City Inspector prior to installation. The unit price per pound for “Additional D.I. Fittings” of the size, type, and class specified shall constitute full compensation for all labor, materials and equipment required for the fittings to be complete in-place, fully operational, and ready for use.

Measurement and payment for mechanical joint fittings shall be made on the basis of the ANSI A21.53 published weights for ductile iron compact MJ fittings not including accessories and not including cement linings.

Measurement and payment for flanged fittings shall be made on the basis of the ANSI A21.10 published weights not including accessories and not including cement linings.

Measurement and payment for RomaGrip-type joint restraints shall be made on the basis of the manufacturer's published weights not including accessories.

Furnishing imported pipe bedding and imported trench backfill will be paid for under the specific items set forth in the Proposal/Construction Contract.

Concrete thrust blocking, shackles, tie rods and other miscellaneous hardware will not be measured for payment and are considered incidental to and included in the price bid for the various items of work.

XX-inch Gate Valve Assembly (Located Outside of Connections)

The unit price per each shall be full compensation for furnishing and installing the gate valve assembly per Plans and Specifications. The price shall include but not be limited to the valve, bricks for support if required, valve box, nut extension, valve marker and appurtenances, milling, excavation, disposal of displaced material, compaction, testing and cleanup. Measurement and payment shall be based upon the number of gate valves installed. This bid item is only intended for gate valves that are not installed as part of a connection. Gate valves installed as part of the connection detail will be paid under the bid item for the connection.

Install New Fire Hydrant Assembly

The unit price per each "Install New Fire Hydrant Assembly" shall be full compensation for furnishing all materials and installing the fire hydrant assembly. This price includes but is not limited to potholing for proposed fire hydrant utility crossings, milling, excavation, compaction, dewatering if required, main line tee, six inch valve, valve box, pipe, thrust restraints, joint restraints, fire hydrant, concrete bearing block, washed rock, geotextile fabric, compaction, blue reflector in pavement, storz adapter, concrete bollard if required, flushing, testing, disinfection, painting, removal of existing fire hydrant and any other items not covered in the other bid items. Measurement and payment for this bid item shall be based on each fire hydrant assembly installed. Measurement and payment for fire hydrants replaced and reconnected to existing main and tees shall be paid for under this bid item.

Note: Backfill for hydrant lead will be paid for under the item for Crushed Surfacing Top Course.

1-Inch Air Vacuum Release Assembly

The unit price per each for "1-Inch Air and Vacuum Release Assembly" shall be full compensation for furnishing and installing the air and vacuum release assembly per Plans and Specifications. The unit price shall include but not be limited to the milling, excavation, compaction, air and vacuum release valve, connection to the water main, saddles, vault, washed gravel, all pipe and fittings, and all appurtenances necessary to provide the air/vac assembly. Payment includes furnishing a new meter box for the assembly. Measurement and payment shall be per each based upon each complete assembly installed.

2-Inch Blowoff Assembly

The unit price per each for "2-Inch Blowoff Assembly" shall be full compensation for furnishing and installing the blowoff assembly per Plans and Specifications. The unit price shall include but not be limited to the milling, excavation, backfill, gate valve, connection to the water main, washed gravel, all pipe and fittings, and all appurtenances necessary to provide the blowoff assembly. Payment includes furnishing a new meter box for the assembly. Measurement and payment shall be per each based upon each complete assembly installed.

1-Inch Water Service, Short Side

The unit price per each for "1-Inch Water Service, Short Side" shall be full compensation for all work to construct each proposed water service connection as shown on the Plans and as specified. This item includes, but is not limited to, exploratory excavation, milling, temporary water service if required, excavation, compaction, tapping the main, saddles, temporary and permanent valves, corporation stops, pipe and fittings, disconnecting and reconnecting the existing service and abandoning the existing service connection, proposed setter and adapter, proposed water service line, meter box installation and relocation, miscellaneous materials, testing, flushing, and disinfecting the new service connection complete and

operational, and reconnection and adjustment of individual PRV if required. No additional payment shall be made for services which are bored as shown on the plans or at the Contractor's option. Measurement and payment shall be per each water service installed.

This item includes the Contractor installing the new or existing water meter and reusing the existing meter box but does not include the cost of the water meter. The City will provide a new meter if needed and some meter boxes may be reused. The Contractor will install the meter (new or existing) under this bid item. New meter boxes are to be provided by the City unless the existing box is to remain as noted in the water service tables on the plans.

1-Inch Water Service, Long Side

The unit price per each for "1-Inch Water Service, Long Side" shall be full compensation for all work to construct each proposed water service connection as shown on the Plans and as specified. This item includes, but is not limited to, exploratory excavation, milling, temporary water service if required, excavation, compaction, tapping the main, saddles, temporary and permanent valves, corporation stops, pipe and fittings, disconnecting and reconnecting the existing service and abandoning the existing service connection, proposed setter and adapter, proposed water service line, meter box installation and relocation, miscellaneous materials, testing, flushing, and disinfecting the new service connection complete and operational, and reconnection and adjustment of individual PRV if required. No additional payment shall be made for services which are bored as shown on the plans or at the Contractor's option. Measurement and payment shall be per each water service installed.

This item includes the Contractor installing the new or existing water meter and reusing the existing meter box but does not include the cost of the water meter. The City will provide a new meter if needed and some meter boxes may be reused. The Contractor will install the meter (new or existing) under this bid item. New meter boxes are to be provided by the City unless the existing box is to remain as noted in the water service tables on the plans.

2-Inch Water Service for 1 ½ -Inch Meter, Short Side

The unit price per each for "2-Inch Water Service for 1 ½ -Inch Meter, Short Side" shall be full compensation for all work to construct each proposed water service connection as shown on the Plans and as specified. This item includes, but is not limited to, exploratory excavation, milling, temporary water service if required, excavation, compaction, tapping the main, saddles, temporary and permanent valves, corporation stops, pipe and fittings, disconnecting and reconnecting the existing service and abandoning the existing service connection, proposed setter and adapter, proposed water service line, meter box installation and relocation, miscellaneous materials, testing, flushing, and disinfecting the new service connection complete and operational, and reconnection and adjustment of individual PRV if required. No additional payment shall be made for services which are bored as shown on the plans or at the Contractor's option. Measurement and payment shall be per each water service installed.

This item includes the Contractor installing the new or existing water meter and reusing the existing meter box but does not include the cost of the water meter. The City will provide a new meter if needed and some meter boxes may be reused. The Contractor will install the meter (new or existing) under this bid item. New meter boxes are to be provided by the City unless the existing box is to remain as noted in the water service tables on the plans.

2-Inch Water Service for 1 ½ -Inch Meter, Long Side

The unit price per each for "2-Inch Water Service for 1 ½ -Inch Meter, Long Side" shall be full compensation for all work to construct each proposed water service connection as shown on the Plans and as specified. This item includes, but is not limited to, exploratory excavation, milling, temporary water service if required, excavation, compaction, tapping the main, saddles, temporary and permanent valves, corporation stops, pipe and fittings, disconnecting and reconnecting the existing service and abandoning the existing service connection, proposed setter and adapter, proposed water service line, meter box installation and relocation, miscellaneous materials, testing, flushing, and disinfecting the new service connection complete and operational, and reconnection and adjustment of individual PRV if required. No additional payment shall be

made for services which are bored as shown on the plans or at the Contractor's option. Measurement and payment shall be per each water service installed.

This item includes the Contractor installing the new or existing water meter and reusing the existing meter box but does not include the cost of the water meter. The City will provide a new meter if needed and some meter boxes may be reused. The Contractor will install the meter (new or existing) under this bid item. New meter boxes are to be provided by the City unless the existing box is to remain as noted in the water service tables on the plans.

Intercept Existing Water Service

The unit contract price per each for "Intercept Existing Water Service" shall be full pay for all material, labor, and equipment, complete and in place, for all work to intercept existing service and connect to new main as shown on standard detail W-14. This includes but is not limited to excavation at old main, cutting service at old main, valve, adjusting valve can to grade, saddle, and corporation stop. If the Contractor damages the existing service and intercept is not possible, no additional payment will be made for installation of new service line.

Customer Side Reconnection Over 5 Feet

The force account price for "Customer Side Reconnection Over 5 Feet" shall be full compensation for all costs including labor, equipment, tools and materials for potholing, locating, hole hogging, and connecting the back side of the new meter location to the existing customer side service line within the served property when this connection exceeds five (5) feet.

Connection X to Existing Water System

The lump sum price for "Connection X to Existing Water System" shall be full compensation for the connection of the proposed water main to the existing water system per the Plans and Specifications. The price shall include milling, excavation, dewatering and proper disposal of water, hauling and disposal of excess or unsuitable material, temporary blow offs, temporary backflow prevention apparatus, pipe, spools, fittings, gate valves, thrust restraints including but not limited to mechanically mixed concrete blocking, Romagrips, gaskets, bolts and other hardware, removal of existing plugs, pipe sterilization, testing, disposal of excess material, compaction, cutting and capping the existing main, and clean up. Measurement and payment shall be for the entire connection complete in-place, fully operational, and ready for use.

Note: The City will notify affected residents in advance, conduct the shutdown and recharge the water main.

Wet Tap Connection X to Existing Water System

The lump sum price for "Wet Tap Connection X to Existing Water System" shall be full compensation for the connection of the proposed water main to the existing water system per the Plans and Specifications. The price shall include milling, excavation, dewatering and proper disposal of water, hauling and disposal of excess or unsuitable material, temporary blow offs, temporary backflow prevention apparatus, temporary pipe, tapping tee and tapping valve, spools, fittings, gate valves, thrust restraints included but not limited to mechanically mixed concrete blocking, Romagrips, gaskets, bolts and other hardware, removal of existing plugs, pipe sterilization, testing, disposal of excess material, compaction, cutting and capping the existing main, and clean up. Tapping sleeve shall be as shown on standard detail W-24A. Measurement and payment shall be for the entire connection complete in-place, fully operational, and ready for use.

Note: The City will notify affected residents in advance, conduct the shutdown and recharge the water main.

Abandon Existing Water System

The lump sum price for "Abandon Existing Water System" shall be full compensation for the abandonment of existing water main and other water facilities as shown in the Plans and Specifications. The price shall include but not be limited to milling, excavation, cutting and draining the existing water system including proper disposal of water, removal of all indicated tees, valves, and valve boxes within the abandonment limits on the lines to be abandoned, air/vacuum assemblies, blow-off assemblies, and fire hydrants,

concrete for plugging existing pipe, caps, pipe spools and sleeves where tees are removed, temporary and permanent thrust blocking where required, and other material necessary to abandon the existing system, disposal of excess material, compaction, and clean up. It shall also include time for shutdown of the existing system by the water department and time for flushing of the new main.

Controlled Density Fill (CDF) (As Necessary)

The cubic yard price for “Controlled Density Fill (CDF) (As Necessary)” shall be full compensation for all labor, materials and equipment required to furnish and place Controlled Density Fill (CDF) for utility crossings or as directed by the engineer.

Adjust Monument to Grade

The unit price per each of “Adjust Monument to Grade” shall be full compensation for all labor, equipment, tools, and materials necessary to adjust the elevation of monument case and cover to finish grade as shown, either raising or lowering, on the plans including but not limited to sawcutting, jack hammering, material disposal, compaction, and shims. No additional payments shall be made for adjustments during construction. If existing monument is damaged by the Contractor during adjustment, no additional payment will be made for installation and setting of new monument.

Cement Concrete Sidewalk

The square yard price for “Cement Concrete Sidewalk” shall be full compensation for installing sidewalk as shown on the plans including subgrade preparation, sawcutting, compaction, formwork, form adjustments, procuring and placing concrete, joint materials, finishing, excavation, spoils haul, and disposal. This price shall also include work for exposed aggregate finish as indicated on the plans.

Note: Crushed surfacing top course used for subgrade shall be paid under the bid item for crushed surfacing top course.

Cement Concrete Curb and Gutter

The linear foot price for “Cement Concrete Curb and Gutter” shall be full compensation for work to completely install curbs to lines and grades specified on the plans, including but not limited to subgrade preparation, compaction, sawcutting, forming and adjustment, procuring and placing concrete, joint materials, finishing, curing, stripping forms, and painting.

Note: Crushed surfacing top course used for subgrade shall be paid under the bid item for crushed surfacing top course.

Additional Temporary Erosion and Sedimentation Control (TESC)

The force account price for “Additional Temporary Erosion and Sedimentation Control (TESC)” will be made for TESC beyond the need for Catch Basin Inserts, and shall be full compensation for furnishing all materials, installation, maintenance and removal as required. Additional TESC measures may be required based on weather and field conditions at the time of construction. This includes, but is not limited to, excavation, fence installation “keying in” fence fabric or straw wattles, maintenance of fence during construction, removal and disposal of fence, restoration of surface following fence removal, and maintenance of the TESC system, excluding Catch Basin Inserts.

Catch Basin Insert

The unit price per each “Catch Basin Insert” shall be full compensation for all labor, equipment, tools and materials required to install, inspect daily, continually maintain throughout the duration of the project as recommended by the manufacturer and remove upon project completion. Measurement and payment will be per each catch basin insert in place. If the same catch basin insert is moved to different catch basins as the work zone moves, it will only be paid once.

Property and Landscape Restoration

The force account price for “Property and Landscape Restoration” shall be full pay for preserving, removing, and restoring existing lawn, shrubs, landscaping plantings, rockeries, fences, and other restoration of disturbed surfaces, improvements, and features, resulting from the construction, except for HMA pavement removal and restoration, and crushed surfacing. Also included is the cost of repairing or replacing irrigation systems that are damaged by construction activities.

Temporary Pavement Markings

The force account price for “Temporary Pavement Markings” shall be full pay for constructing, maintaining and removing temporary lines and markers during construction where instructed by the City. No payment will be made for temporary markings installed without prior direction from the City.

Plastic Stop Line

The linear foot price for “Plastic Stop Line” shall be full compensation for restoration of stop line disturbed during construction. The price shall include removal of existing damaged pavement markings, preliminary spotting, preparing roadway surfaces, and installation of pavement markings.

Plastic Crosswalk Line

The square foot price for “Plastic Crosswalk Line” shall be full compensation for restoration of crosswalk line disturbed during construction. The price shall include removal of existing damaged pavement markings, preliminary spotting, preparing roadway surfaces, and installation of pavement markings.

Paint Line

The linear foot price for “Paint Line” shall be full compensation for restoration of yellow or white paint line disturbed during construction. The price shall include preliminary spotting, preparing roadway surfaces, and installation of pavement markings, including glass beads as required.

Traffic Letter/Number

The unit price per each for “Traffic Letter/Number” shall be full compensation for restoration of plastic traffic letter/number disturbed during construction. The price shall include removal of existing damaged pavement markings, preliminary spotting, preparing roadway surfaces, and installation of pavement markings.

Raised Pavement Marker Type XX

The per hundred price for “Raised Pavement Marker Type XX” shall be full compensation for restoration of any raised pavement markers disturbed during construction. The price shall include preliminary spotting, preparing roadway surfaces, adhesive, and installation of raised pavement markers.

Precast Dual Faced Sloped Mountable Curb

The linear foot price for “Precast Dual Faces Sloped Mountable Curb” shall be full compensation for restoration of curb disturbed during construction. The price shall include removal of existing damaged curb, preliminary spotting, preparing roadway surfaces, epoxy adhesive, paint and installation of curb.

APPENDIX A PREVAILING MINIMUM HOURLY WAGE RATES

This Page Intentionally Left Blank

PREVAILING WAGES

The State of Washington prevailing wage rates for King County apply to work performed under this contract. The applicable prevailing wage rates may be found at the following website address of the Department of Labor and Industries:

<https://fortress.wa.gov/lni/wagelookup/prvWagelookup.aspx>

Based on the bid submittal date for this project, the applicable date for prevailing wages for this project is March 30, 2022. A copy of the applicable prevailing wage rates are also available for viewing at the City of Mercer Island, Maintenance Department located at 9611 SE 36th Street.

This Page Intentionally Left Blank

This Page Intentionally Left Blank

BUFFER DATA	
LONGITUDINAL BUFFER SPACE = B	
SPEED (MPH)	25 30 35 40 45 50 55 60 65 70
LENGTH (feet)	155 200 250 305 360 425 495 570 645 730
TRANSPORTABLE ATTENUATOR ROLL AHEAD DISTANCE = R	
HOST VEHICLE WEIGHT	
< 45 MPH	45-55 MPH
45-55 MPH	> 55 MPH
100'	123'
172'	74'
100'	150'
PROTECTIVE VEHICLE (WORK VEHICLE) = R	
NO SPECIFIED DISTANCE REQUIRED	

SIGN SPACING = X (1)	
RURAL HIGHWAYS	60 / 65 MPH 800' ±
RURAL ROADS	45 / 55 MPH 500' ±
RURAL ROADS & URBAN ARTERIALS	35 / 40 MPH 350' ±
RURAL ROADS, URBAN ARTERIALS, RESIDENTIAL & BUSINESS DISTRICTS	25 / 30 MPH 200' ± (2)
URBAN STREETS	25 MPH OR LESS 100' ± (2)

(1) ALL SPACING MAY BE ADJUSTED TO ACCOMMODATE INTERSECTIONS AND DRIVEWAYS.
 (2) THIS SPACING MAY BE REDUCED IN URBAN AREAS TO FIT ROADWAY CONDITIONS.

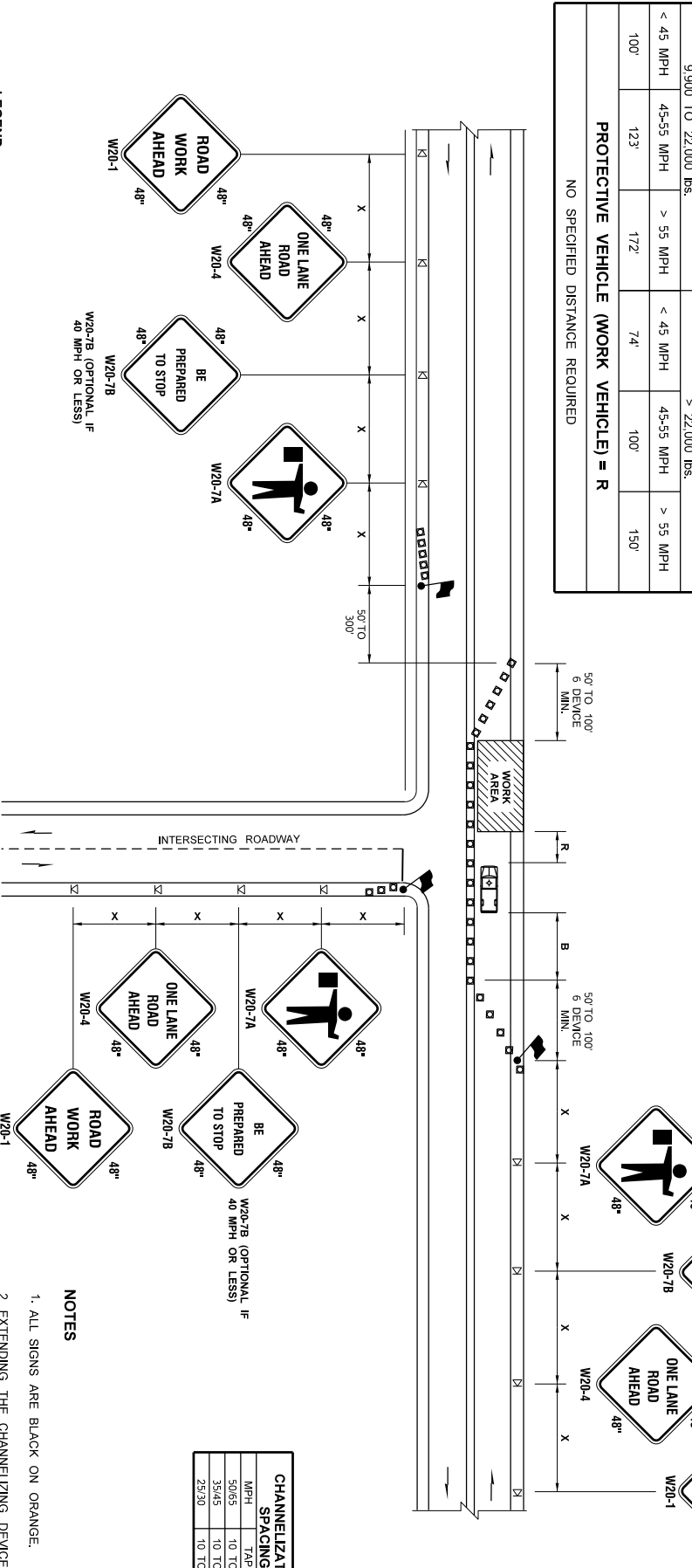

CHANNELIZATION DEVICE SPACING (FEET)			
MPH	TAPER	TANGENT	
50/65	10 TO 20	80	
35/45	10 TO 20	60	
25/30	10 TO 20	40	

- NOTES**
1. ALL SIGNS ARE BLACK ON ORANGE.
 2. EXTENDING THE CHANNELIZING DEVICE TAPER ACROSS SHOULDER IS RECOMMENDED.
 3. NIGHT WORK REQUIRES ADDITIONAL ROADWAY LIGHTING AT FLAGGING STATIONS, SEE THE STANDARD SPECIFICATIONS FOR ADDITIONAL DETAILS.
 4. SEE SPECIAL PROVISIONS FOR WORK HOUR RESTRICTIONS.

- LEGEND**
- FLAGGING STATION
 - TEMPORARY SIGN LOCATION
 - CHANNELIZING DEVICES
 - PROTECTIVE VEHICLE

ONE-LANE, TWO-WAY TRAFFIC CONTROL WITH FLAGGERS

NOT TO SCALE

FILE NAME S:\Design R_RR_S&S\Standard\3-Plan Sheet Library\04-Published ES&UT(C) Work Zone Traffic Control\CA One Lane Two Way Traffic Control with Flaggers\TC1.dgn	
DATE 12/21/18 DESIGNED BY IRRH CHECKED BY PROJECT ENGR. DESIGNED BY CHECKED BY PROJECT ENGR.	DATE BY DATE BY
WASH FEDERAL PROJ.NO. LOCATION NO.	CONTRACT NO. DATE DATE
WASHINGTON STATE DEPARTMENT OF TRANSPORTATION	TRAFFIC CONTROL PLAN
FIG 1 PLAN SHEET NO. TC1	SHEET OF SHEETS

APPENDIX C POTHOLE DATA

This Page Intentionally Left Blank

Create Date	2022-02-03
Pothole Number	1
Overlay Thickness (in) Asphalt	7
Overlay Thickness (in) Concrete	NA
Overlay Thickness (in) Brick	NA
Utility Type	Water
Utility Size (in)	10
Utility Material	Cast Iron
Pipe Direction	N & S
Soil Cond.	Dirt
Top of Utility from Grade (in)	48
Bottom of Utility from Grade (in)	58
Pipe Condition	(2)Fair-Brittle pipe/pitted/rusty
Width of Structure (in)	
Notes	
2/03/2022 jdj@apslocates.com DI water line running E & W 34"-42"	
CL Offset 1	11' South of approx CL of SE 36th St
CL Offset 2	11' East of approx CL of 88th Ave SE
GPS Uncertainty	0.59ft
Created By	
Created Date	
Edited By	jdj@apslocates.com
Edited Date	2022-02-03 11:50
GPS Latitude	47.5781412
GPS Longitude	-122.2220257
GPS Elevation	275.5ft
GPS Time	2022-02-03 11:36:03
GPS Data	provider: \$GPGGA quality: DIF satellites: 19 diffID: 0133 geoid separation: -18.416M hdop: 0.7 diffAge: 7.0sec Vertical Accuracy: 0.349m

Create Date	2022-02-03
Pothole Number	1a
Overlay Thickness (in) Asphalt	8
Overlay Thickness (in) Concrete	NA
Overlay Thickness (in) Brick	NA
Utility Type	Water
Utility Size (in)	8
Utility Material	Ductile Iron
Pipe Direction	E & W
Soil Cond.	rocky
Top of Utility from Grade (in)	51
Bottom of Utility from Grade (in)	59
Pipe Condition	(3)Good-well definded/no pits
Width of Structure (in)	
Notes	
2/03/2022 jd@apslocates.com top of thrust is 49"	
CL Offset 1	approx 13' west of CL of 88th ave se
CL Offset 2	approx 11' north of cl of driveway 3601
GPS Uncertainty	0.57ft
Created By	
Created Date	
Edited By	jd@apslocates.com
Edited Date	2022-02-03 11:07
GPS Latitude	47.5781283
GPS Longitude	-122.2221174
GPS Elevation	274.0ft
GPS Time	2022-02-03 10:23:04
GPS Data	provider: \$GPGGA quality: DIF satellites: 17 diffID: 0138 geoid separation: -18.416M hdop: 0.8 diffAge: 26.0sec Vertical Accuracy: 0.385m

Create Date	2022-02-02
Pothole Number	2
Overlay Thickness (in) Asphalt	NA
Overlay Thickness (in) Concrete	NA
Overlay Thickness (in) Brick	NA
Utility Type	
Utility Size (in)	
Utility Material	
Pipe Direction	
Soil Cond.	hard clay
Top of Utility from Grade (in)	
Bottom of Utility from Grade (in)	
Pipe Condition	
Width of Structure (in)	
Notes	
2/03/2022 gabes@apslocates.com dug 5ft by 3ft wide did not find.	
CL Offset 1	11' east from approx cl of 88th ave se
CL Offset 2	66' north from approx cl of se 37th ave
GPS Uncertainty	0.4ft
Created By	
Created Date	
Edited By	gabes@apslocates.com
Edited Date	2022-02-03 12:02
GPS Latitude	47.5771508
GPS Longitude	-122.2220433
GPS Elevation	280.8ft
GPS Time	2022-02-03 11:50:24
GPS Data	provider: \$GPGGA satellites: 22 diffID: 0131 geoid separation: -18.416M hdop: 0.6 diffAge: 6.0sec Vertical Accuracy: 0.267m

Create Date	2022-02-02
Pothole Number	3
Overlay Thickness (in) Asphalt	NA
Overlay Thickness (in) Concrete	NA
Overlay Thickness (in) Brick	NA
Utility Type	Water
Utility Size (in)	4
Utility Material	Cast Iron
Pipe Direction	E & W
Soil Cond.	mud
Top of Utility from Grade (in)	42
Bottom of Utility from Grade (in)	46
Pipe Condition	(3)Good-well definded/no pits
Width of Structure (in)	
Notes	
CL Offset 1	16' north from approx cl of se 37th st.
CL Offset 2	26' east from approx cl of 8802 driveway
GPS Uncertainty	0.8ft
Created By	gabes@apslocates.com
Created Date	2022-02-03 13:21
Edited By	gabes@apslocates.com
Edited Date	2022-02-03 13:32
GPS Latitude	47.5770089
GPS Longitude	-122.2215103
GPS Elevation	282.7ft
GPS Time	2022-02-03 13:21:44
GPS Data	provider: SGP GGA satellites: 20 diffID: 0138 geoid separation: -18.416M hdop: 0.6 diffAge: 7.0sec Vertical Accuracy: 0.532m
Attachments	

Create Date	2022-02-03
Pothole Number	3a
Overlay Thickness (in) Asphalt	NA
Overlay Thickness (in) Concrete	NA
Overlay Thickness (in) Brick	NA
Utility Type	
Utility Size (in)	
Utility Material	
Pipe Direction	
Soil Cond.	mud
Top of Utility from Grade (in)	
Bottom of Utility from Grade (in)	
Pipe Condition	
Width of Structure (in)	
Notes	
2/03/2022 gabes@apslocates.com did not find unlocateable dug ti 6ft deep by 4ft wide	
CL Offset 1	26' east from approx cl of 8802 driveway
CL Offset 2	17' north from approx cl of se 37th st
GPS Uncertainty	1.5ft
Created By	
Created Date	
Edited By	gabes@apslocates.com
Edited Date	2022-02-03 14:06
GPS Latitude	47.5770106
GPS Longitude	-122.2215333
GPS Elevation	282.7ft
GPS Time	2022-02-03 14:00:55
GPS Data	provider: \$GPGGA satellites: 19 diffID: 0133 geoid separation: -18.416M hdop: 0.7 diffAge: 7.0sec Vertical Accuracy: 1.271m

Create Date	2022-02-03
Pothole Number	3a
Overlay Thickness (in) Asphalt	NA
Overlay Thickness (in) Concrete	NA
Overlay Thickness (in) Brick	NA
Utility Type	
Utility Size (in)	
Utility Material	
Pipe Direction	
Soil Cond.	mud
Top of Utility from Grade (in)	
Bottom of Utility from Grade (in)	
Pipe Condition	
Width of Structure (in)	
Notes	
2/03/2022 gabes@apslocates.com did not find unlocateable. dug 6ft deep by 4ft wide	
CL Offset 1	26' east from approx cl of 8802 driveway
CL Offset 2	17' north from approx cl of se 37th st
GPS Uncertainty	0.8ft
Created By	gabes@apslocates.com
Created Date	2022-02-03 13:52
Edited By	gabes@apslocates.com
Edited Date	2022-02-03 13:57
GPS Latitude	47.5770007
GPS Longitude	-122.2215151
GPS Elevation	285.6ft
GPS Time	2022-02-03 13:52:08
GPS Data	provider: \$GPGGA satellites: 21 diffID: 0138 geoid separation: -18.416M hdop: 0.6 diffAge: 7.0sec Vertical Accuracy: 0.608m

Create Date	2022-02-03
Pothole Number	4
Overlay Thickness (in) Asphalt	NA
Overlay Thickness (in) Concrete	NA
Overlay Thickness (in) Brick	NA
Utility Type	Water
Utility Size (in)	4
Utility Material	Cast Iron
Pipe Direction	E & W
Soil Cond.	Dirt
Top of Utility from Grade (in)	34
Bottom of Utility from Grade (in)	38
Pipe Condition	(3)Good-well definded/no pits
Width of Structure (in)	
Notes	
CL Offset 1	approx 15' north of Cl of se 37th st
CL Offset 2	approx 60' west of cl of 90 ave se
GPS Uncertainty	0.65ft
Created By	
Created Date	
Edited By	jdj@apslocates.com
Edited Date	2022-02-03 13:07
GPS Latitude	47.5770009
GPS Longitude	-122.2193657
GPS Elevation	264.7ft
GPS Time	2022-02-03 12:40:59
GPS Data	provider: \$GPGGA quality: DIF satellites: 17 diffID: 0133 geoid separation: -18.415M hdop: 0.7 diffAge: 5.0sec Vertical Accuracy: 0.473m

Create Date	2022-02-03
Pothole Number	4A
Overlay Thickness (in) Asphalt	NA
Overlay Thickness (in) Concrete	NA
Overlay Thickness (in) Brick	NA
Utility Type	Water
Utility Size (in)	10
Utility Material	AC
Pipe Direction	E & W
Soil Cond.	Dirt
Top of Utility from Grade (in)	38
Bottom of Utility from Grade (in)	48
Pipe Condition	(2)Fair-Brittle pipe/pitted/rusty
Width of Structure (in)	
Notes	
CL Offset 1	approx 12' north of cl of se 37th st
CL Offset 2	approx 60' west of cl of 90 ave se
GPS Uncertainty	0.56ft
Created By	
Created Date	
Edited By	jdj@apslocates.com
Edited Date	2022-02-03 13:08
GPS Latitude	47.5769991
GPS Longitude	-122.2193730
GPS Elevation	264.9ft
GPS Time	2022-02-03 12:35:42
GPS Data	provider: \$GPGGA quality: DIF satellites: 19 diffID: 0133 geoid separation: -18.415M hdop: 0.7 diffAge: 5.0sec Vertical Accuracy: 0.444m

Create Date	2022-02-03
Pothole Number	5
Overlay Thickness (in) Asphalt	NA
Overlay Thickness (in) Concrete	NA
Overlay Thickness (in) Brick	NA
Utility Type	Water
Utility Size (in)	10
Utility Material	AC
Pipe Direction	N & S
Soil Cond.	dirt/ clay
Top of Utility from Grade (in)	32
Bottom of Utility from Grade (in)	42
Pipe Condition	(3)Good-well definded/no pits
Width of Structure (in)	
Notes	
CL Offset 1	23' east from cl of 90th ave s
CL Offset 2	15' north from approx cl of 3714 driveway
GPS Uncertainty	0.5ft
Created By	
Created Date	
Edited By	gabes@apslocates.com
Edited Date	2022-02-03 14:43
GPS Latitude	47.5765945
GPS Longitude	-122.2190398
GPS Elevation	266.0ft
GPS Time	2022-02-03 14:34:18
GPS Data	provider: SGP GGA satellites: 17 diffID: 0133 geoid separation: -18.415M hdop: 0.7 diffAge: 6.0sec Vertical Accuracy: 0.415m
Attachments	

Create Date	2022-02-03
Pothole Number	6
Overlay Thickness (in) Asphalt	4
Overlay Thickness (in) Concrete	NA
Overlay Thickness (in) Brick	NA
Utility Type	Water
Utility Size (in)	10
Utility Material	AC
Pipe Direction	N & S
Soil Cond.	dirt
Top of Utility from Grade (in)	27
Bottom of Utility from Grade (in)	37
Pipe Condition	(3)Good-well definded/no pits
Width of Structure (in)	
Notes	
CL Offset 1	19' east from approx cl of 90th ave se
CL Offset 2	44' north from approx cl of 3734 driveway
GPS Uncertainty	0.7ft
Created By	gabes@apslocates.com
Created Date	2022-02-03 15:07
Edited By	gabes@apslocates.com
Edited Date	2022-02-03 15:09
GPS Latitude	47.5761310
GPS Longitude	-122.2190539
GPS Elevation	277.4ft
GPS Time	2022-02-03 15:07:31
GPS Data	provider: SGPGGA satellites: 20 diffID: 0133 geoid separation: -18.416M hdop: 0.6 diffAge: 7.0sec Vertical Accuracy: 0.533m
Attachments	

Create Date	2022-02-03
Pothole Number	7
Overlay Thickness (in) Asphalt	6
Overlay Thickness (in) Concrete	NA
Overlay Thickness (in) Brick	NA
Utility Type	Water
Utility Size (in)	10
Utility Material	AC
Pipe Direction	N & S
Soil Cond.	dirt
Top of Utility from Grade (in)	34
Bottom of Utility from Grade (in)	44
Pipe Condition	(3)Good-well definded/no pits
Width of Structure (in)	
Notes	
CL Offset 1	19' east from approx cl of 90th ave se
CL Offset 2	55' north from cl of se 40th st
GPS Uncertainty	0.6ft
Created By	gabes@apslocates.com
Created Date	2022-02-03 15:28
Edited By	gabes@apslocates.com
Edited Date	2022-02-03 15:32
GPS Latitude	47.5747229
GPS Longitude	-122.2190570
GPS Elevation	289.9ft
GPS Time	2022-02-03 15:28:29
GPS Data	provider: SGP GGA satellites: 16 diffID: 0133 geoid separation: -18.417M hdop: 0.7 diffAge: 5.0sec Vertical Accuracy: 0.456m
Attachments	

Create Date	2022-02-03
Pothole Number	8
Overlay Thickness (in) Asphalt	6
Overlay Thickness (in) Concrete	NA
Overlay Thickness (in) Brick	NA
Utility Type	Water
Utility Size (in)	10
Utility Material	AC
Pipe Direction	E & W
Soil Cond.	dirt
Top of Utility from Grade (in)	39
Bottom of Utility from Grade (in)	49
Pipe Condition	(3)Good-well definded/no pits
Width of Structure (in)	
Notes	
CL Offset 1	13' east from approx cl of 91st ave se
CL Offset 2	19' ' north from cl of se 40th st.
GPS Uncertainty	0.8ft
Created By	
Created Date	
Edited By	gabes@apslocates.com
Edited Date	2022-02-03 16:04
GPS Latitude	47.5746132
GPS Longitude	-122.2173598
GPS Elevation	300.7ft
GPS Time	2022-02-03 16:01:59
GPS Data	provider: SGP GGA satellites: 20 diffID: 0131 geoid separation: -18.416M hdop: 0.6 diffAge: 6.0sec Vertical Accuracy: 0.537m
Attachments	

APPENDIX D STANDARD DETAILS

This Page Intentionally Left Blank

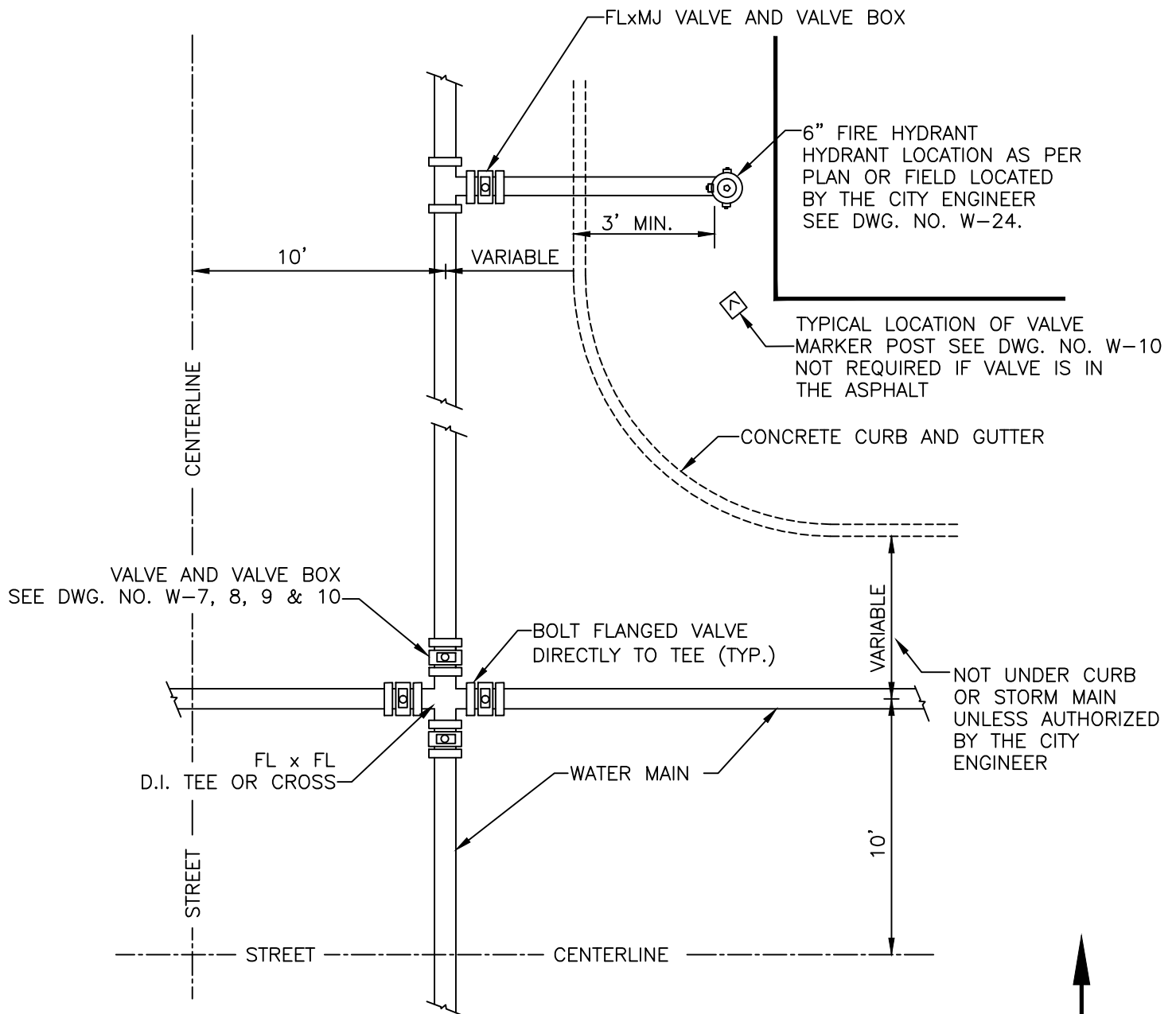

NOTES

1. MECHANICAL JOINTS WITH ROMAC PIPE RESTRAINERS MAY BE USED AT FITTINGS IN LIEU OF FLANGE TO FLANGE CONNECTIONS SHOWN ABOVE, WHERE APPROVED BY THE CITY ENGINEER.
2. BUTTERFLY VALVE OPERATING NUTS SHALL BE ON THE NORTH AND WEST SIDE OF THE MAIN.



**CITY OF MERCER ISLAND
STANDARD DETAILS
WATER**

INTERSECTION LAYOUT

08-12-2009

NO SCALE

W-2

REV DATE

APPROVED

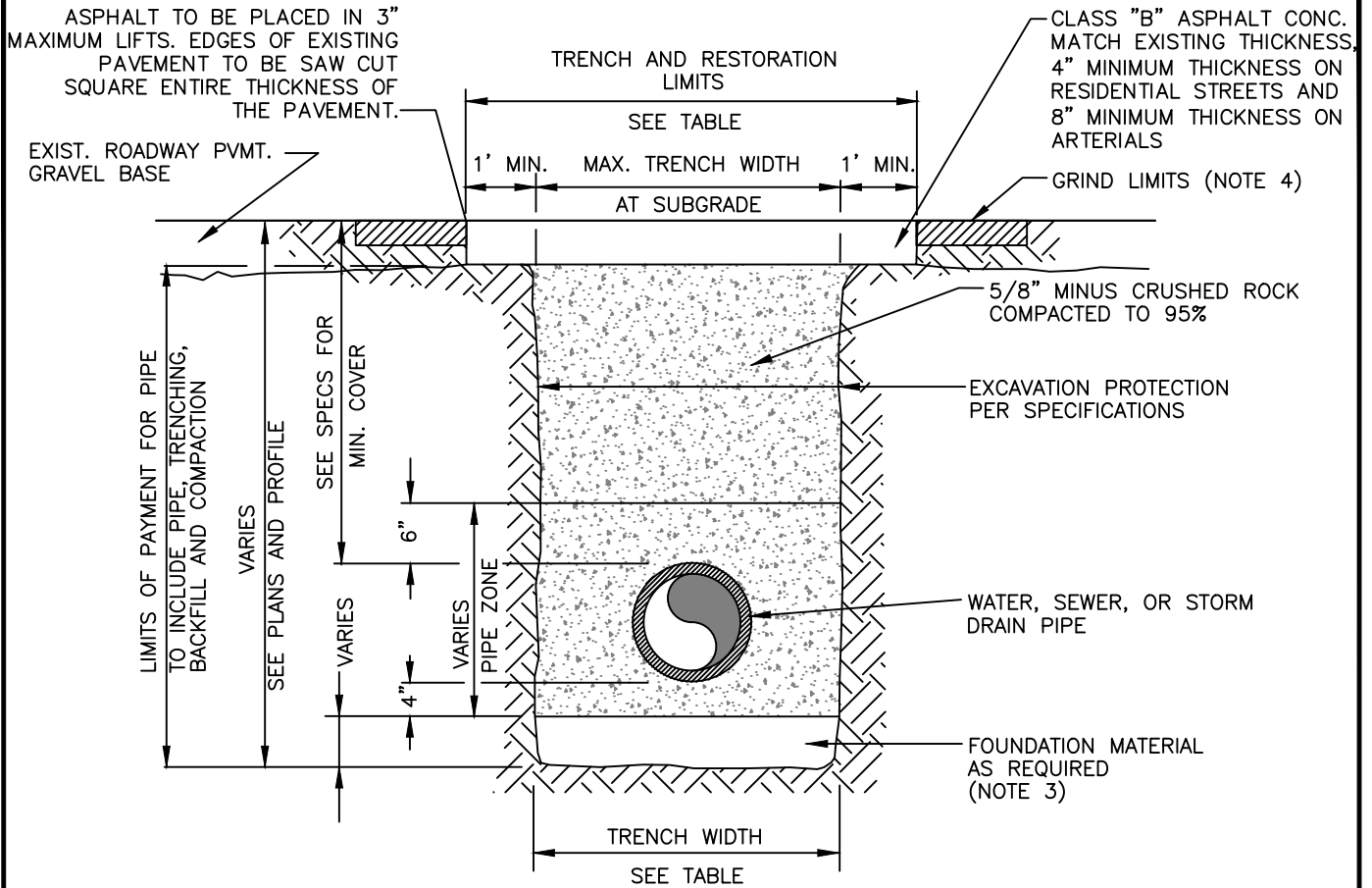

WIDTH TRENCH			
PIPE SIZE	PIPE ZONE MAX. TRENCH WIDTH	MAX. TRENCH WIDTH AT SUBGRADE	MAX. RESTORATION WIDTH AT SURFACE
WATER SERVICES	2'-0"	2'-0"	4'-0"
4" OR 6"	2'-2"	3'-0"	5'-0"
8"	2'-4"	4'-0"	6'-0"
10"	2'-6"	4'-0"	6'-0"
12"	2'-8"	4'-6"	6'-6"
16"	3'-0"	5'-0"	7'-0"

NOTES

1. CALL IN LOCATES TWO BUSINESS DAYS BEFORE YOU DIG. (1-800-424-5555)
2. IN RIGHT-OF-WAY USE 100% 5/8 MINUS CRUSHED ROCK FOR BEDDING, PIPE ZONE AND BACKFILL
3. FOUNDATION MATERIAL SHALL BE 1 1/4" MINUS CRUSHED ROCK OR OTHER AGGREGATE AS APPROVED BY CITY ENGINEER.
4. GRIND AND OVERLAY LIMITS SHALL EXTEND A MINIMUM OF 10' PAST THE END OF TRENCH AREAS.
5. SEAL ALL FINAL PATCHING AND PAVING SEAMS WITH LIQUID ASPHALT. SQUEEGEE OR MOP THE SEALER. COVER WITH DRY SAND.



**CITY OF MERCER ISLAND
STANDARD DETAILS
WATER**

TRENCH SECTION

3-29-2021

NO SCALE

W-3

APPROVED

THRUST BLOCKING TABLE

PIPE SIZE	MINIMUM BEARING AREA AGAINST UNDISTURBED SOIL IN SQUARE FEET				
	A	B	C	D	E
4	2	2	2	2	2
6	4	3	2	2	2
8	7	5	4	2	2
10	11	8	6	3	2
12	16	12	9	5	3
14	22	16	12	6	3
16	29	20	16	8	4

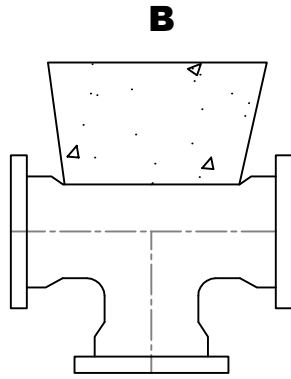

TEE

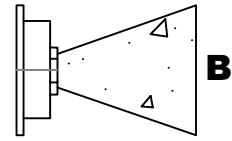

MJ CAP

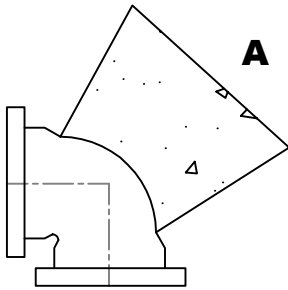

90° BEND

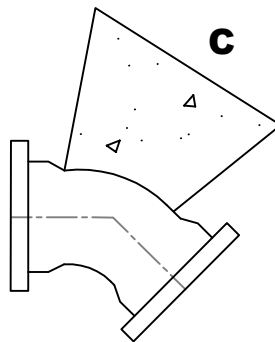

45° BEND

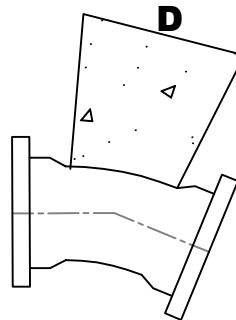

22-1/2° BEND

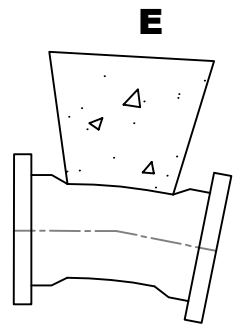

11-1/4° BEND

NOTES

1. ROMAC MJ WEDGE ACTION RETAINER MAY BE SUBSTITUTED FOR VERTICAL BLOCKING UPON PRIOR APPROVAL OF THE CITY ENGINEER.
2. CONCRETE THRUST BLOCKING SHALL BE POURED AGAINST UNDISTURBED EARTH.
3. THRUST BLOCKS SHALL BE CAST-IN-PLACE AND BE CONSTRUCTED WITH CLASS 3000 OR COMMERCIAL CONCRETE.
4. BLOCK SHALL BEAR AGAINST FITTINGS ONLY AND SHALL BE CLEAR OF BOLTS AND JOINTS TO PERMIT TAKING UP OR DISMANTLING JOINT. WRAP FITTINGS WITH 8 MIL THICK POLYETHYLENE SHEETING PRIOR TO POURING CONCRETE.
5. BEARING AREA MUST BE ADJUSTED FOR HIGHER INTERNAL PRESSURES AND LOWER SOIL BEARING VALUES.
6. THE CONTRACTOR SHALL INSTALL BLOCK WHICH IS ADEQUATE TO WITHSTAND FULL TEST PRESSURE AS WELL AS TO CONTINUOUSLY STAND OPERATING PRESSURE UNDER ALL CONDITIONS OF SERVICE.



CITY OF MERCER ISLAND STANDARD DETAILS WATER

HORIZONTAL CONCRETE BLOCKING

3-30-2021

NO SCALE

W-5A

VERTICAL THRUST BLOCKING
FOR 11 1/4° - 22 1/2° - 45°

PIPE SIZE NOM. DIAMETER - INCHES	TEST PRESSURE P.S.I.	VB VERTICAL BEND DEGREES	AMOUNT CONCERT BLOCKING - CU. FT.	S LENGTH OF SIDE FEET	d SHACKLE ROD DIA. - INCHES	L DEPTH OF ROD IN CONCRETE INCHES	NUMBER OF TIE RODS SETS (2 EMBEDDED RODS PER SET)
3"	250	11-1/4	3.4	1.5	5/8"	12"	2
		22-1/2	5.4	1.75	5/8"	12"	2
		45	11.4	2.25	5/8"	12"	2
4"	250	11-1/4	5.4	1.75	5/8"	12"	2
		22-1/2	11.4	2.25	5/8"	12"	2
		45	20.8	2.75	5/8"	12"	2
6"	250	11-1/4	11.4	2.25	5/8"	12"	2
		22-1/2	27.0	3.0	5/8"	12"	2
		45	42.9	3.5	5/8"	12"	2
8"	250	11-1/4	20.8	2.75	5/8"	12"	2
		22-1/2	42.9	3.5	5/8"	12"	2
		45	76.8	4.25	5/8"	12"	2
10"	250	11-1/4	34.3	3.25	5/8"	12"	2
		22-1/2	64.0	4.0	5/8"	12"	2
		45	125	5.0	5/8"	12"	2
12"	250	11-1/4	42.9	3.5	5/8"	12"	2
		22-1/2	91.1	4.5	5/8"	12"	2
		45	166	5.5	5/8"	12"	4
14"	250	11-1/4	52.7	3.75	3/4"	12"	2
		22-1/2	107	4.75	3/4"	24"	2
		45	190	5.75	3/4"	24"	4
16"	250	11-1/4	64.0	4.0	3/4"	24"	2
		22-1/2	125	5.0	3/4"	24"	4
		45	216	6.0	3/4"	24"	4
18"	250	11-1/4	64.0	4.0	3/4"	24"	2
		22-1/2	145	5.25	3/4"	24"	4
		45	244	6.25	3/4"	24"	4

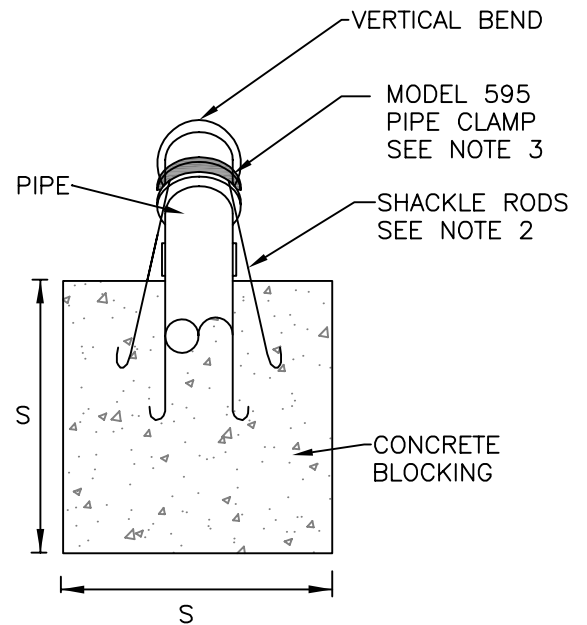
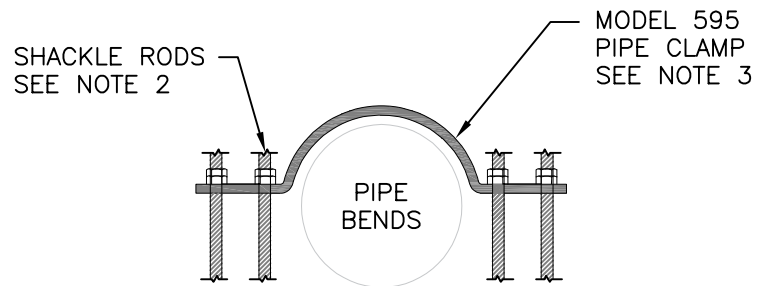
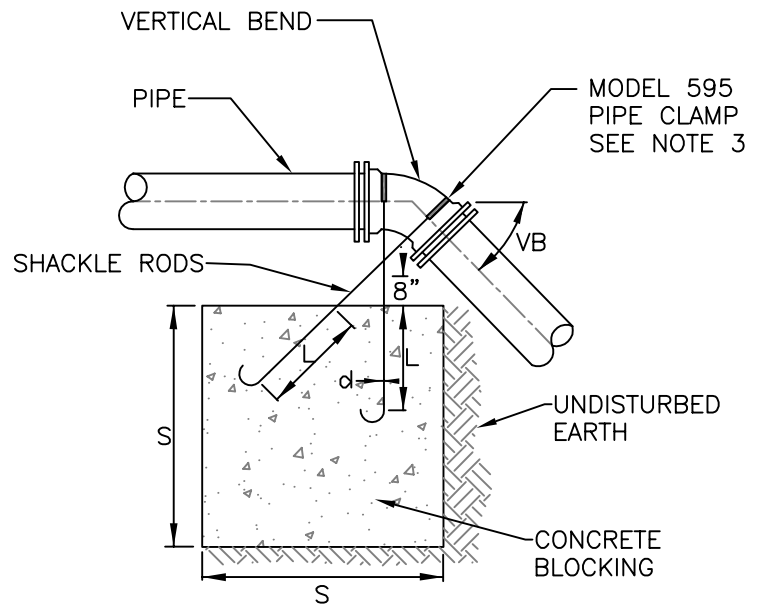

BLOCKING FOR VERTICAL BENDS

NOTES

1. CONCRETE SHALL BE 3000 PSI CONCRETE
2. SHACKLE RODS/ALL THREAD SHALL BE ZINC PLATED. REFER TO CHART FOR SIZE AND NUMBER OF SHACKLE RODS. REFER TO PIPE CLAMP FOR INSTALLATION OF SHACKLE ROD. AFTER CONCRETE IS PLACED. 24 HOURS LATER INSTALL NUT AND WASHER AND TIGHTEN SHACKLE RODS NUTS ON PIPE CLAMP.
3. ANVIL PIPE CLAMP 595 FITS 4"-24" DIA.



**CITY OF MERCER ISLAND
STANDARD DETAILS
WATER**

VERTICAL CONCRETE BLOCKING

3-30-2021

NO SCALE

W-5B

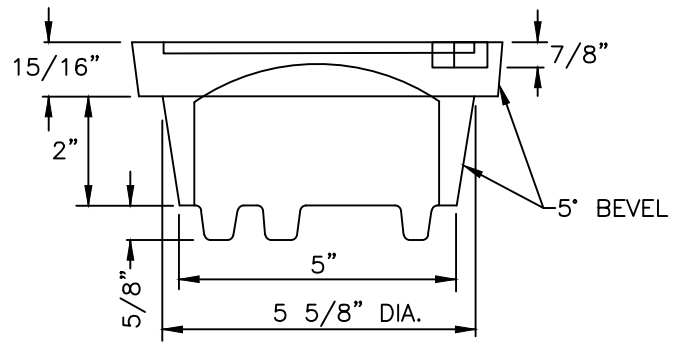
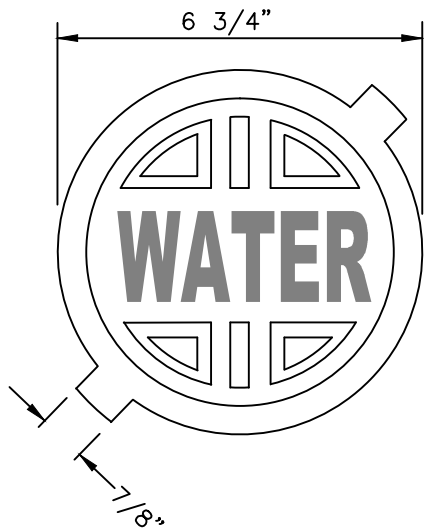

VALVE BOX LID

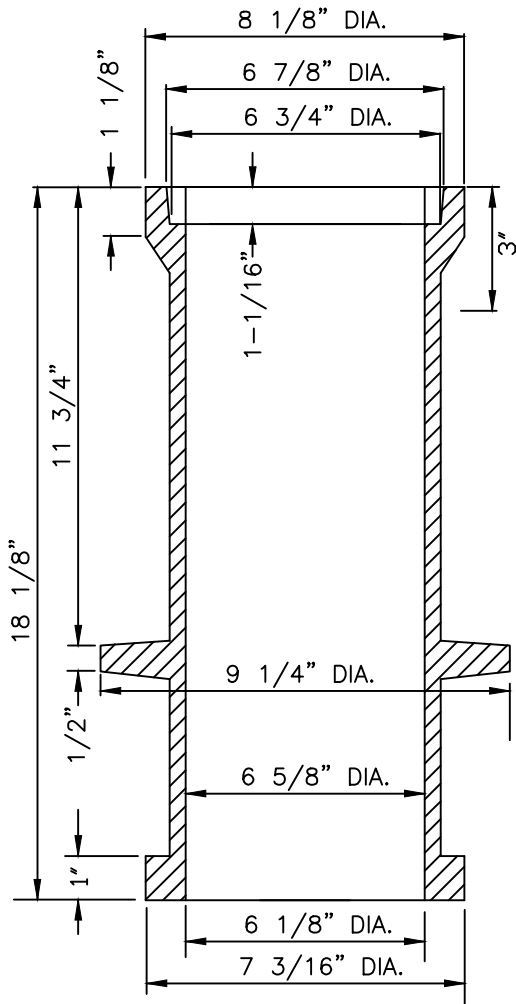

VALVE BOX TOP

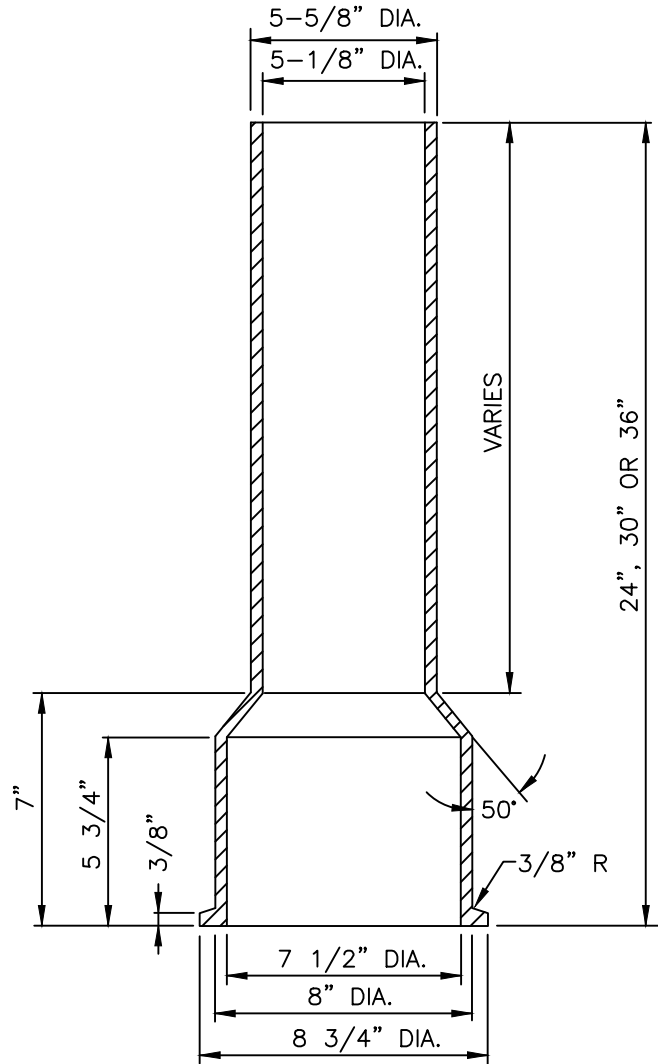

VALVE BOX BOTTOM

NOTES

1. VALVE BOX SHALL BE OLYMPIC FOUNDRY PART NO. VB940 OR EQUAL.
2. THE TOP AND LID SHALL HAVE A MACHINED FIT.
3. LOCKING LID, WHEN REQUIRED, SHALL BE OLYMPIC FOUNDRY PART NO. 13-5200 OR EQUAL.



CITY OF MERCER ISLAND
STANDARD DETAILS
WATER

WATER VALVE BOX

3-20-2006

NO SCALE

W-7

REV DATE

APPROVED

4'-0" MAX.
IF OVER 4'
SEE DWG. NO. W-9

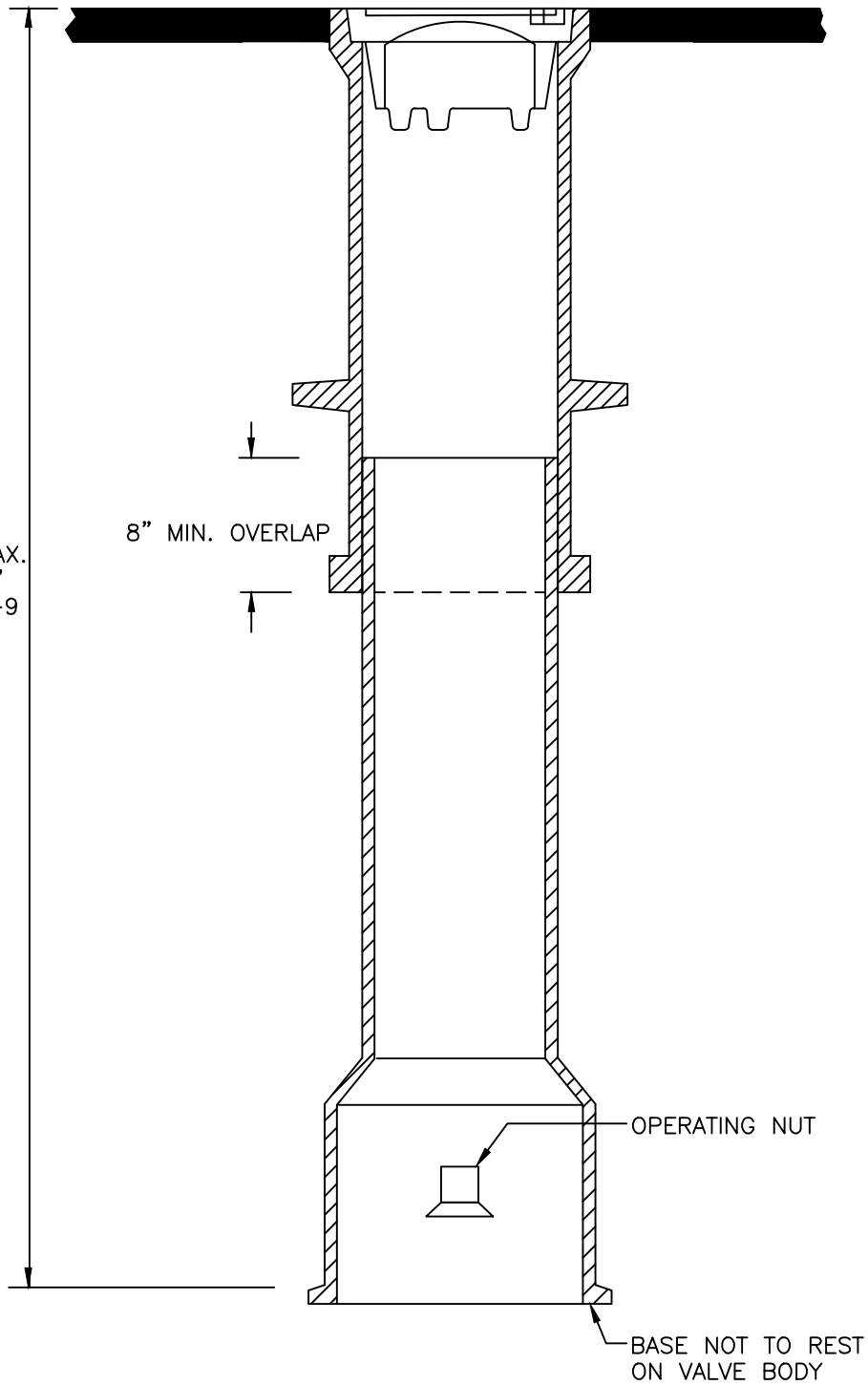

NOTES

1. VALVE BOX RISER WITH PAVING LUGS SHALL BE OLYMPIC NO. VB2 OR EQUAL.
2. MINIMUM VALVE BOX BOTTOM LENGTH OVERALL = 21 1/16". SHORT RISERS ARE NOT PERMITTED.
3. SEE DWG. NO. W-7 FOR DETAILS.



**CITY OF MERCER ISLAND
STANDARD DETAILS
WATER**

WATER VALVE BOX

12-23-2013

NO SCALE

W-8

REV DATE

APPROVED

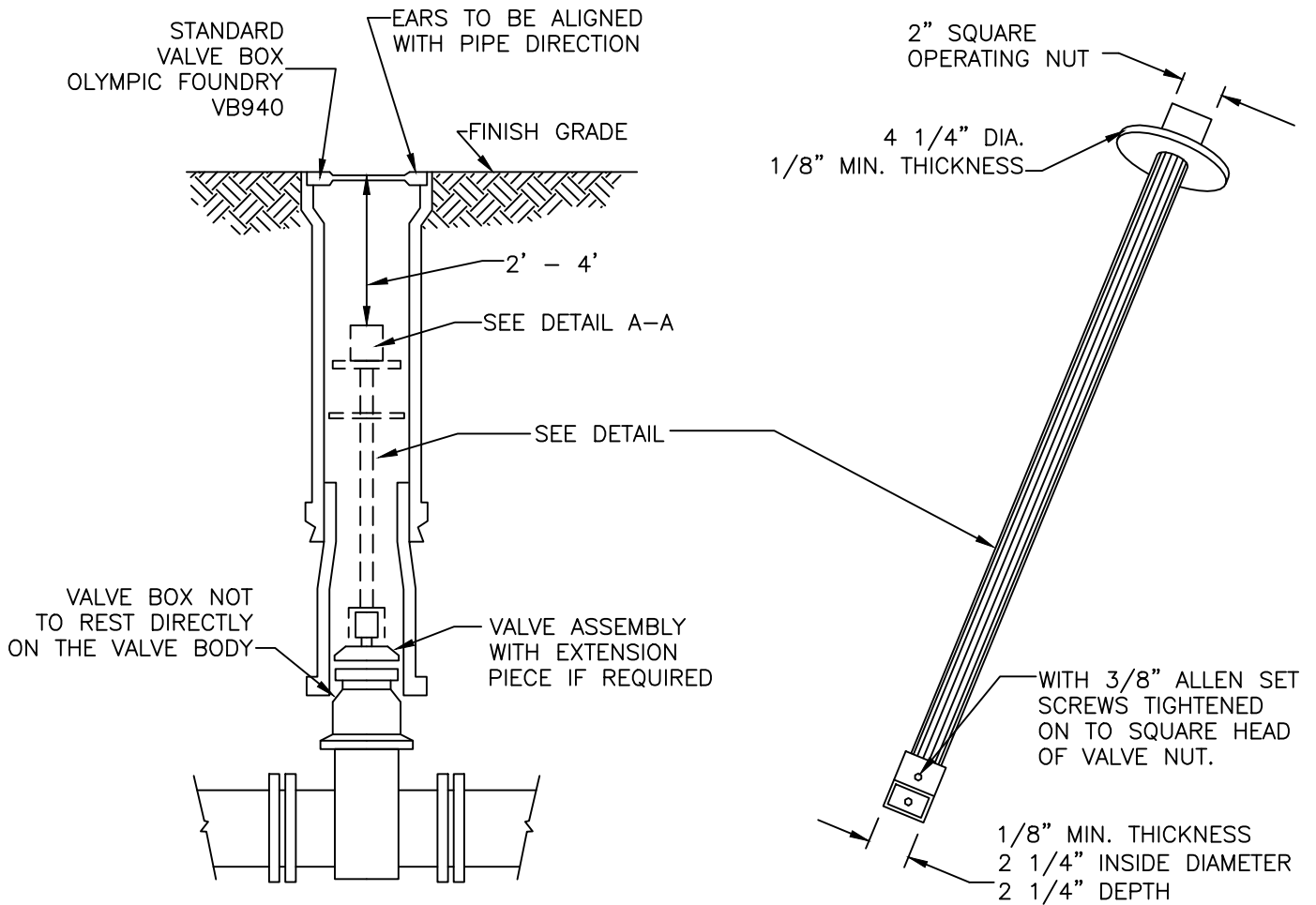

SECTION

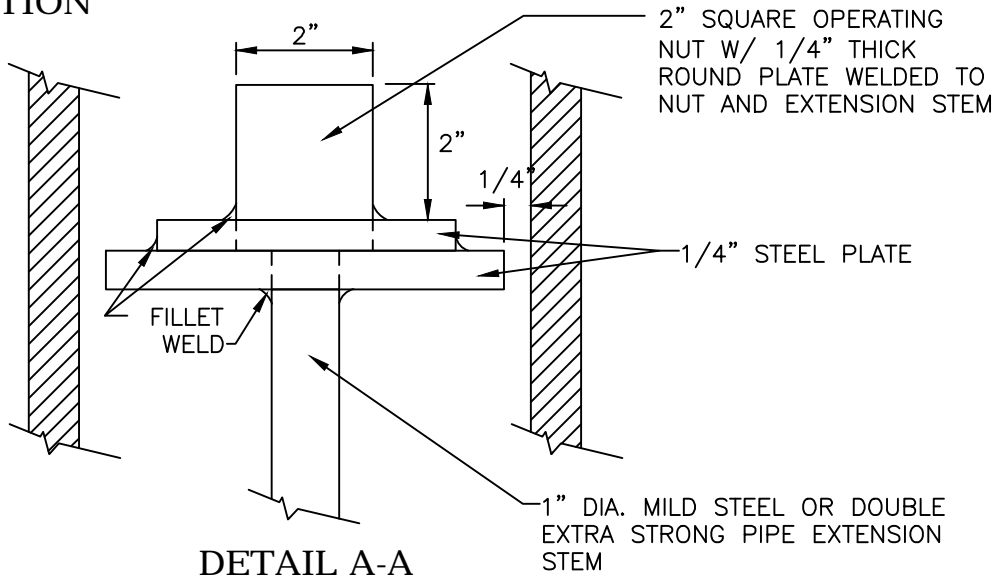

DETAIL A-A

NOTES

1. EXTENSIONS ARE REQUIRED WHEN THE VALVE NUT IS MORE THAN FOUR (4) FEET BELOW FINISHED GRADE.
2. EXTENSIONS ARE TO BE A MINIMUM OF ONE (1) FOOT LONG. ONLY ONE EXTENSION PER VALVE WILL BE ALLOWED.
3. ALL EXTENSIONS ARE TO BE MADE OF CAST OR DUCTILE IRON, SIZED AS NOTED AND PAINTED WITH TWO COATS ASPHALTIC VARNISH.

	CITY OF MERCER ISLAND STANDARD DETAILS WATER	
	WATER VALVE EXTENSION	
12-23-2013	NO SCALE	W-9
REV DATE		APPROVED

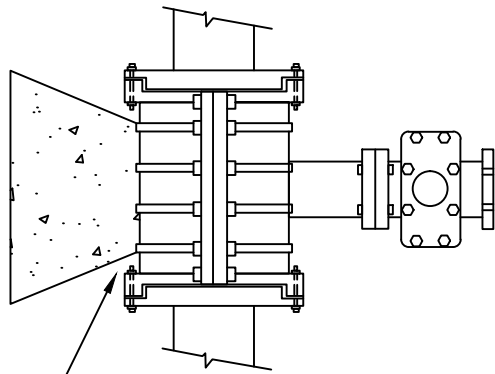

SEE W-5 FOR 8 MIL THICK
POLYETHYLENE SHEETING
(TO MATCH W-5)

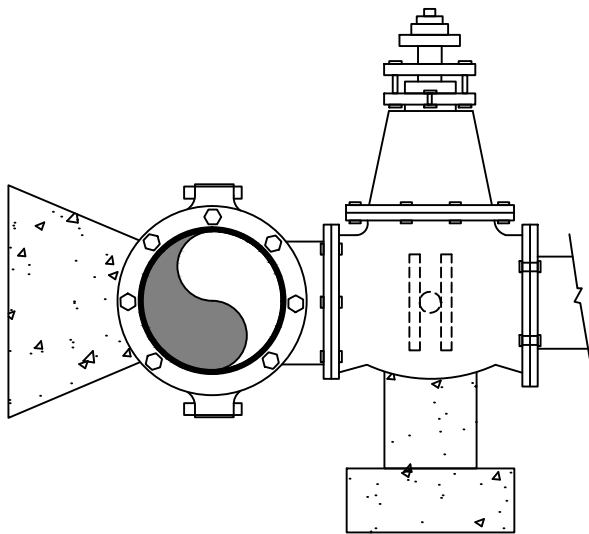
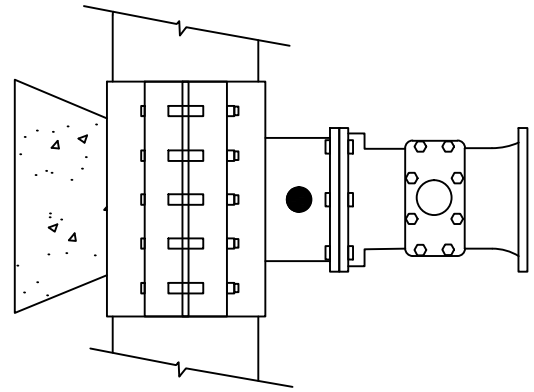

DUCTILE IRON TAPPING TEE MECHANICAL JOINT SLEEVE

INSTALLED ON ASBESTOS CEMENT PIPE,
CAST IRON PIPE AND DUCTILE IRON PIPE

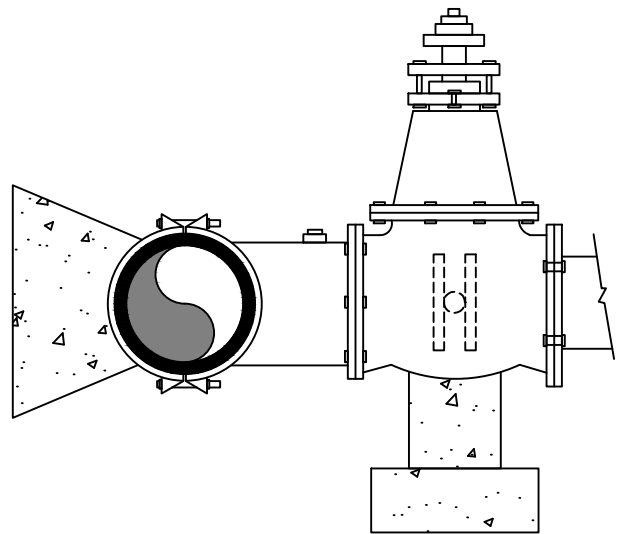

STAINLESS STEEL TAPPING TEE

INSTALLED ON ASBESTOS CEMENT PIPE,
CAST IRON PIPE AND DUCTILE IRON PIPE

NOTES

1. STAINLESS STEEL TAPPING TEES SHALL HAVE FULL CIRCLE SEAL.
2. STEEL TAPPING TEES SHALL BE EPOXY COATED.
3. NO SIZE ON SIZE TAPS. TAP SHALL BE AT LEAST 2" SMALLER DIAMETER THAN THE EXISTING MAIN.
4. TAPPING TEES SHALL BE MULLER OR EQUAL.



CITY OF MERCER ISLAND STANDARD DETAILS WATER

TAPPING TEE

8-12-2009

NO SCALE

W-11

REV DATE

APPROVED

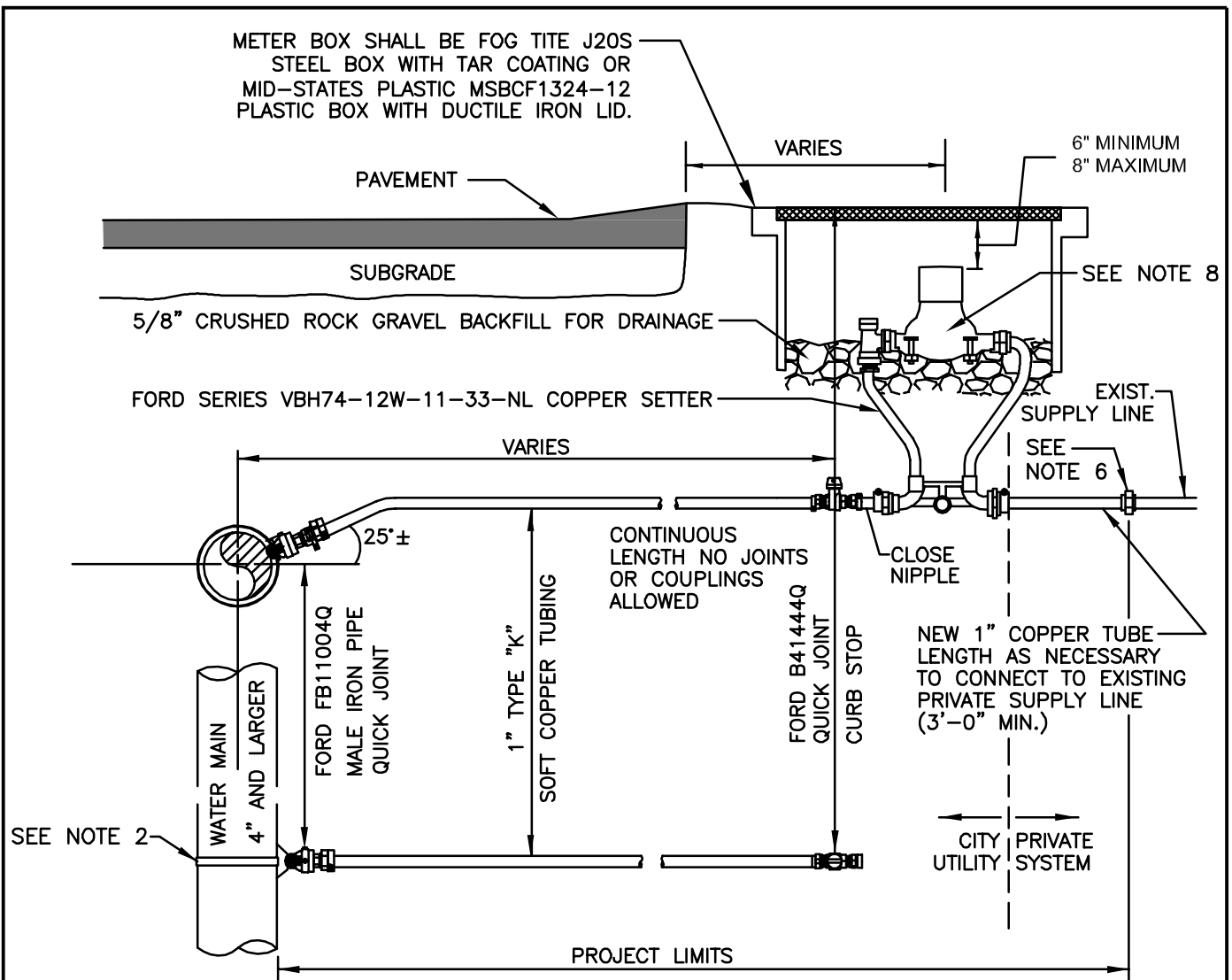

NOTES

1. WATER SERVICES SHALL COMPLY WITH THE REDUCTION OF LEAD IN DRINKING WATER ACT DATED 01/04/2014.
2. ON EXISTING WATER MAINS USE NYLON COATED D.I. SADDLE WITH STAINLESS STEEL DOUBLE STRAPS, ROMAC 202NS, OR APPROVED EQUAL.
3. MINIMUM DISTANCE BETWEEN CORP STOPS SHALL BE 18". MINIMUM DISTANCE BETWEEN TAPS, BETWEEN CORP STOP AND PIPE ENDS SHALL BE 24", ALL HORIZONTALLY STAGGERED.
4. PLASTIC METER BOXES SHALL NOT BE INSTALLED WITHIN ROADWAY, SIDEWALK, OR DRIVEWAYS.
5. UPON CITY ENGINEER'S APPROVAL, METER BOXES ARE ALLOWED TO BE INSTALLED IN PORTLAND CEMENT CONCRETE PAVEMENT OR SIDEWALK.
6. WHEN CONNECTING TO EXISTING PRIVATE SUPPLY LINE CONTAINING FERROUS METAL, PROVIDE INSULATING COUPLING (DB SERIES WITH C21 SERIES ADAPTERS) AND PROVIDE REDUCER AS NECESSARY TO MATCH EXISTING PRIVATE SUPPLY LINE DIAMETER.
7. SERVICE LINE SHALL BE PERPENDICULAR TO THE WATER MAIN AND STRAIGHT TO WATER METER, UNLESS OTHERWISE APPROVED BY CITY ENGINEER. PROVIDE WINDING SLACK IN THE SERVICE LINE BETWEEN THE MAIN AND WATER METER.
8. WATER METER SUPPLIED BY CITY.
9. ALL FITTINGS TO BE BRASS COMPRESSION TYPE, FORD QUICK JOINT OR EQUAL.
10. NO SERVICE CONNECTIONS BETWEEN BLOW-OFF AND END OF MAIN.

	CITY OF MERCER ISLAND	
	STANDARD DETAILS	
WATER		
1" WATER METER INSTALLATION		
02-05-2021	NO SCALE	
W-13		
APPROVED		

REV DATE					
----------	--	--	--	--	--

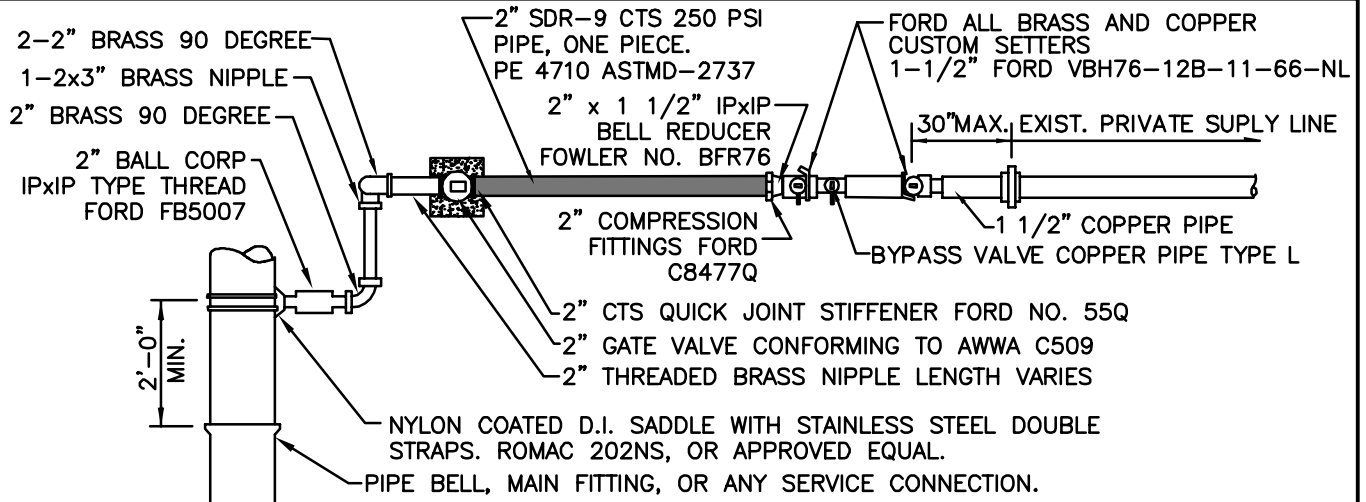

PLAN VIEW

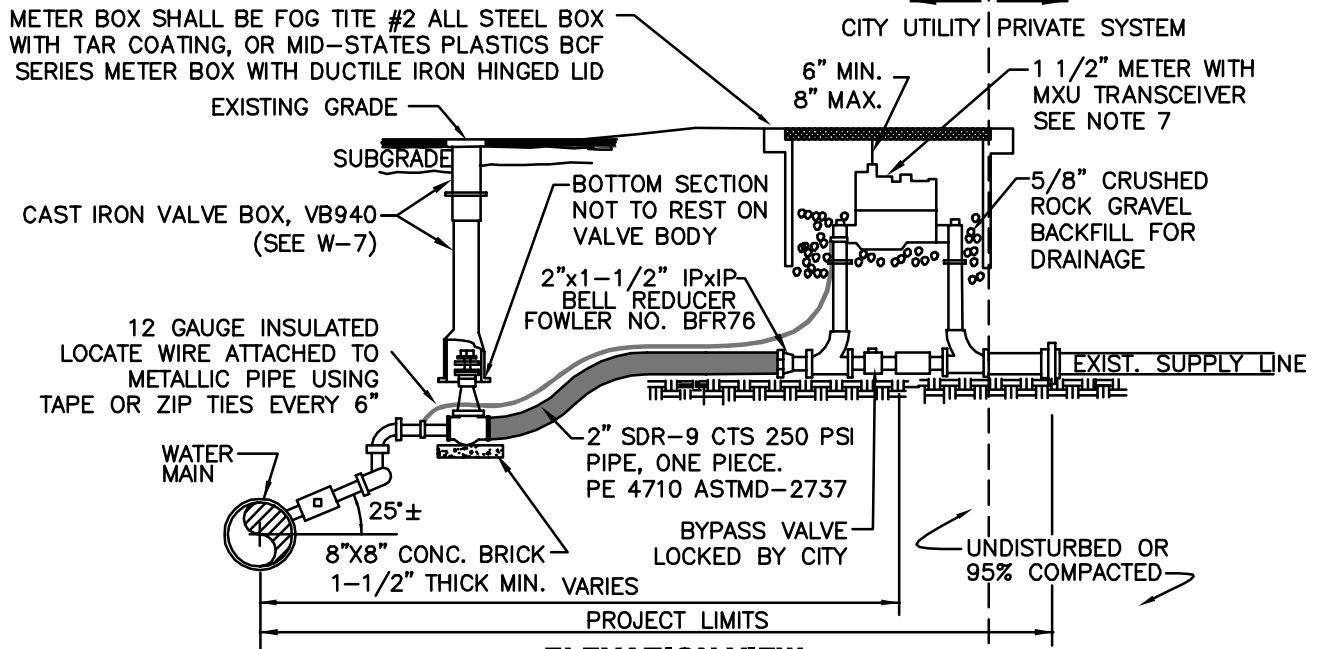

ELEVATION VIEW

NOTES

1. WATER SERVICES SHALL COMPLY WITH THE REDUCTION OF LEAD IN DRINKING WATER ACT DATED 01/04/2014.
2. MINIMUM DISTANCE BETWEEN CORP STOPS SHALL BE 18". MINIMUM DISTANCE BETWEEN TAPS, BETWEEN CORP STOP AND PIPE ENDS SHALL BE 24", ALL HORIZONALLY STAGGERED.
3. PLASTIC METER BOXES SHALL NOT BE INSTALLED WITHIN ROADWAY, SIDEWALK, OR DRIVEWAYS.
4. UPON CITY ENGINEER'S APPROVAL, METER BOXES ARE ALLOWED TO BE INSTALLED IN PORTLAND CEMENT CONCRETE PAVEMENT OR SIDEWALK.
5. WHEN CONNECTING TO EXISTING PRIVATE SUPPLY LINE CONTAINING FERROUS METAL, PROVIDE INSULATING COUPLING (DB SERIES WITH C21 SERIES ADAPTERS) AND PROVIDE REDUCER AS NECESSARY TO MATCH EXISTING PRIVATE SUPPLY LINE DIAMETER.
6. SERVICE LINE SHALL BE PERPENDICULAR TO THE WATER MAIN AND STRAIGHT TO WATER METER, UNLESS OTHERWISE APPROVED BY CITY ENGINEER. PROVIDE WINDING SLACK IN THE SERVICE LINE BETWEEN THE MAIN AND WATER METER.
7. WATER METER SUPPLIED BY CITY.
8. ALL FITTINGS TO BE BRASS COMPRESSION TYPE, FORD QUICK JOINT OR EQUAL.
9. NO SERVICE CONNECTIONS BETWEEN BLOW-OFF AND END OF MAIN.

	CITY OF MERCER ISLAND	
	STANDARD DETAILS	
WATER		
1-1/2" WATER METER INSTALLATION		
02-05-2021	NO SCALE	W-14
REV DATE		APPROVED

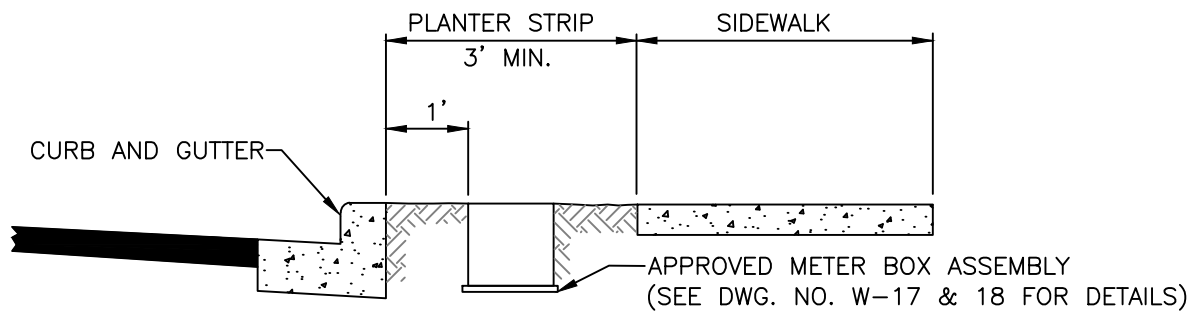

INSTALLATION IN PLANTER STRIP 3' OR WIDER

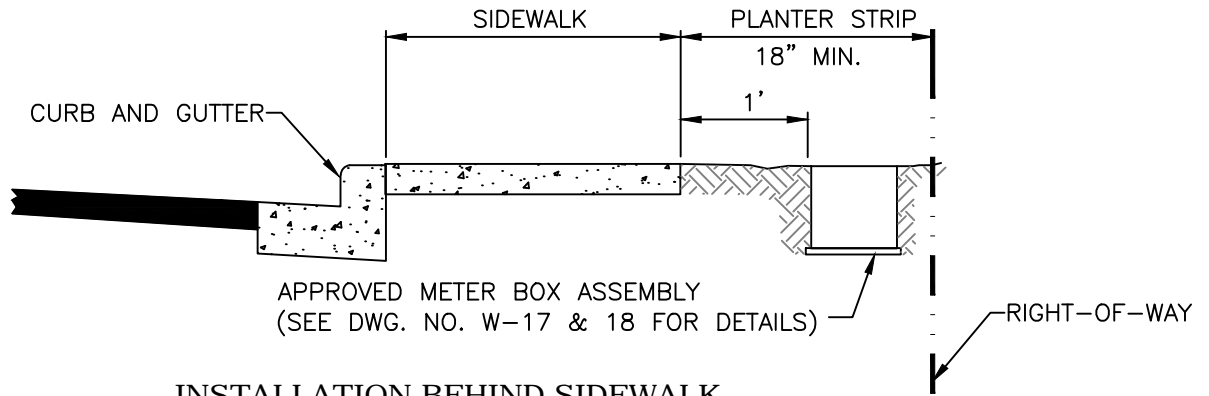

INSTALLATION BEHIND SIDEWALK

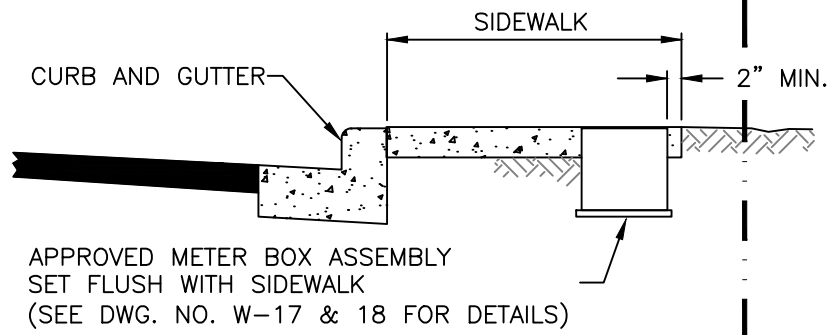

INSTALLATION IN SIDEWALK

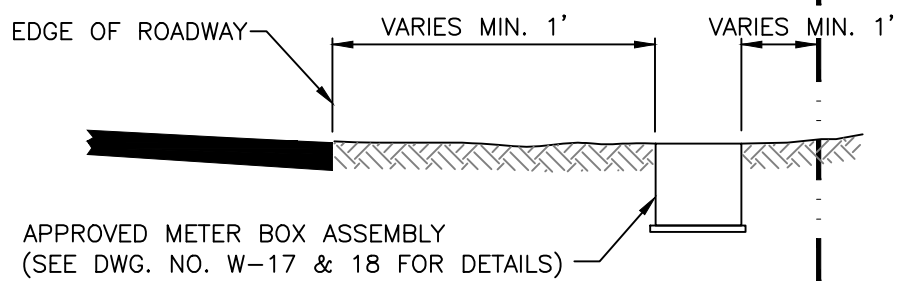

INSTALLATION WITH NO SIDEWALK



CITY OF MERCER ISLAND
STANDARD DETAILS
WATER

WATER METER PLACEMENT

3-20-2006

NO SCALE

W-16

REV DATE

APPROVED

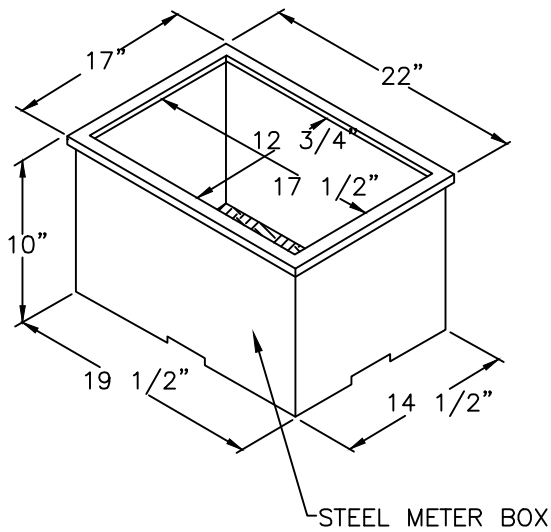
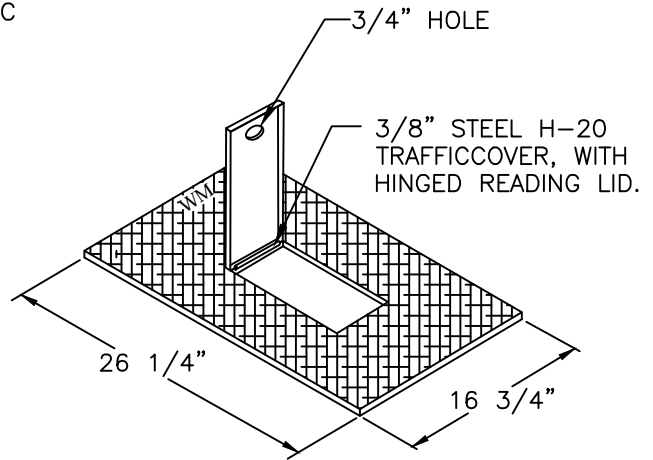
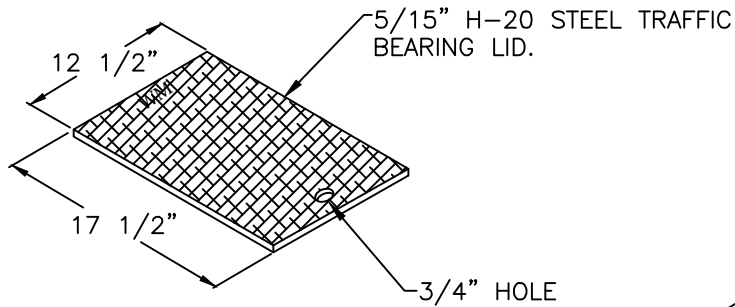

1" STEEL METER BOX

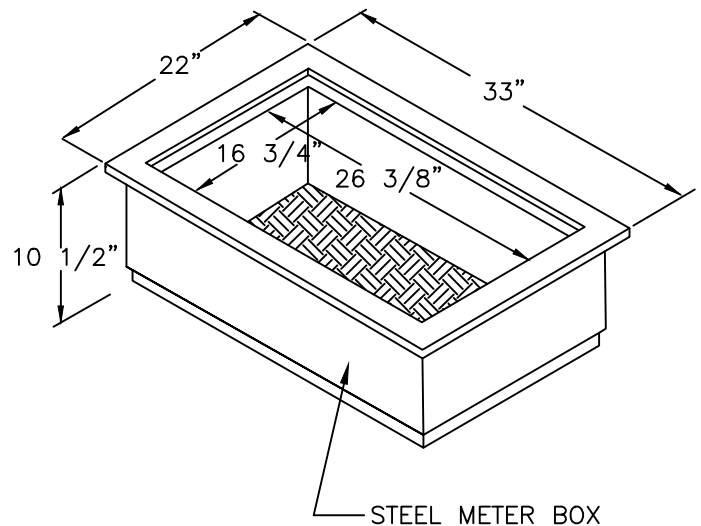

2" STEEL METER BOX

NOTES

1. FOR 1" STEEL BOX, USE FOG TITE J20S LID OR EQUAL, WITH A 3/4" ROUND HOLE.
2. 2" METER BOX SHALL BE FOG TITE #2J20S ALL STEEL BOX WITH TAR COATING. LID SHALL BE HINGED WITH 3/4" DIA. LIFTING HOLE.



CITY OF MERCER ISLAND
STANDARD DETAILS
WATER

1" AND 2" STEEL
WATER METER BOX

12-23-2013

NO SCALE

W-17

REV DATE

APPROVED

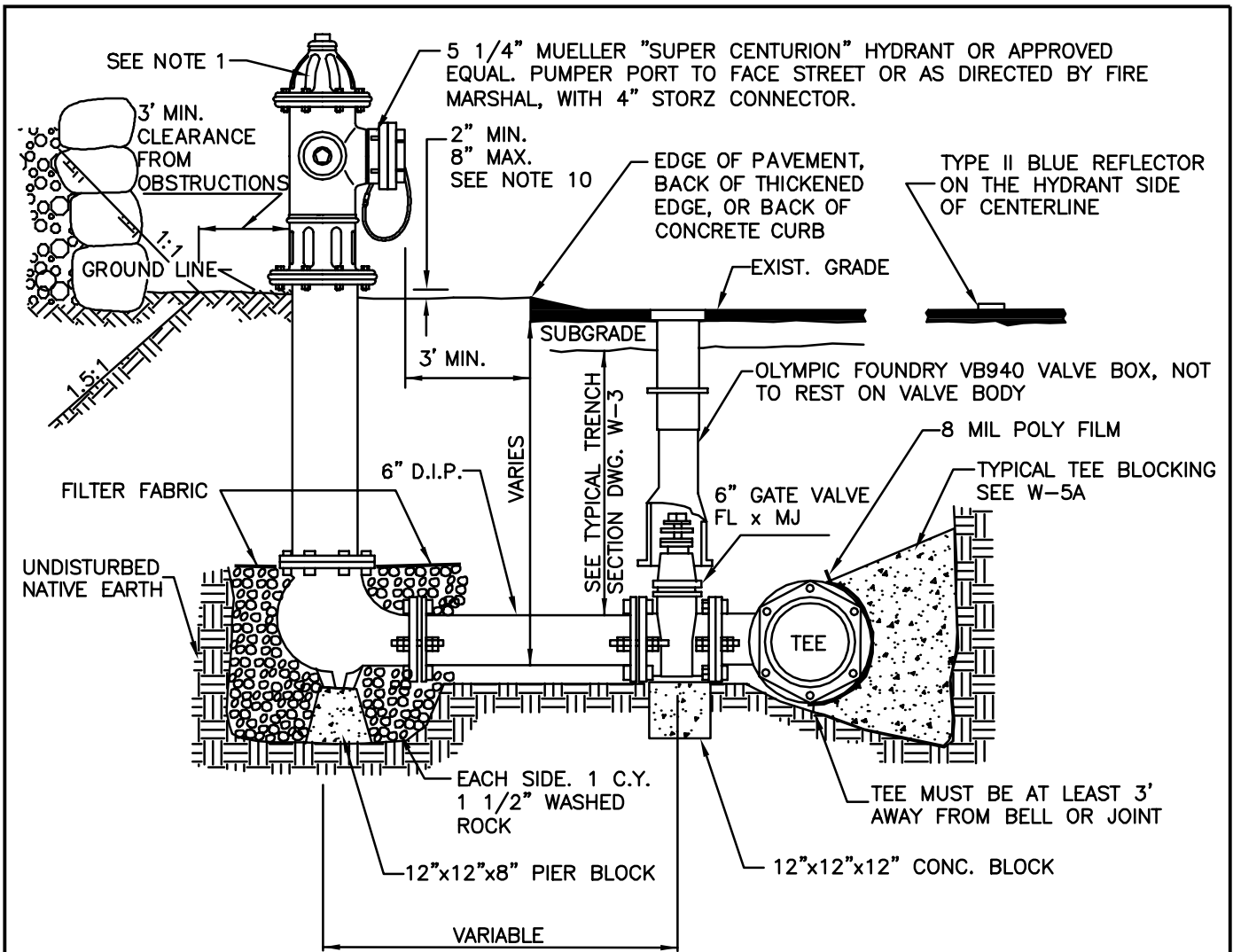

NOTE:

1. 1-5 1/4" M.V.O. HYDRANT WITH 2-2 1/2" N.T.S. M.J. INLET WITH LUGS, BRASS-TO-BRASS SUB-SEAT AND 1-4 1/2" PUMPER, SEATTLE STANDARD PIPE THREAD WITH 4" STORZ CONNECTOR HARRINGTON MODEL NO. HPHA40-40-004/CAP, SIZE 4.875-INCH BY 6-INCH.
2. NO DOMESTIC CONNECTIONS CAN BE MADE TO THE FIRE HYDRANT RUNS.
3. ANY FIRE HYDRANT RUN OVER 18 FEET IN LENGTH OF PIPE SHALL HAVE RESTRAINED JOINT GASKETS.
4. USE ROMA GRIP, OR APPROVED EQUAL, PIPE RESTRAINERS AT VALVE AND HYDRANT BASE.
5. HYDRANT SHALL BE PAINTED WITH 2 COATS OF FARWEST #250 HIGH GLOSS WHITE PAINT, OR APPROVED EQUAL, APPLIED WITH A PAINT BRUSH. DO NOT APPLY PAINT TO STORZ FITTING, BRASS PORT THREADS, OR BELOW SAFETY FLANGE.
6. BOLLARDS MAY BE USED TO PROTECT THE HYDRANT WHEN NO CURBS ARE PRESENT OR IN EXPOSED AREAS OF PARKING LOTS.
7. STRAIGHT PIPE TO HYDRANTS FROM MAIN, NO BENDS.
8. REMOVE CHAINS FROM HYDRANT CAPS.
9. VALVE AND HYDRANT MUST BE PLUMB.
10. THIS DISTANCE IS MEASURED FROM BOTTOM OF SAFETY FLANGE TO LEVEL OF FINISH GRADE BELOW HYDRANT.

	CITY OF MERCER ISLAND STANDARD DETAILS WATER	
	FIRE HYDRANT CONNECTION	
02-23-2021	NO SCALE	W-24
REV DATE		APPROVED

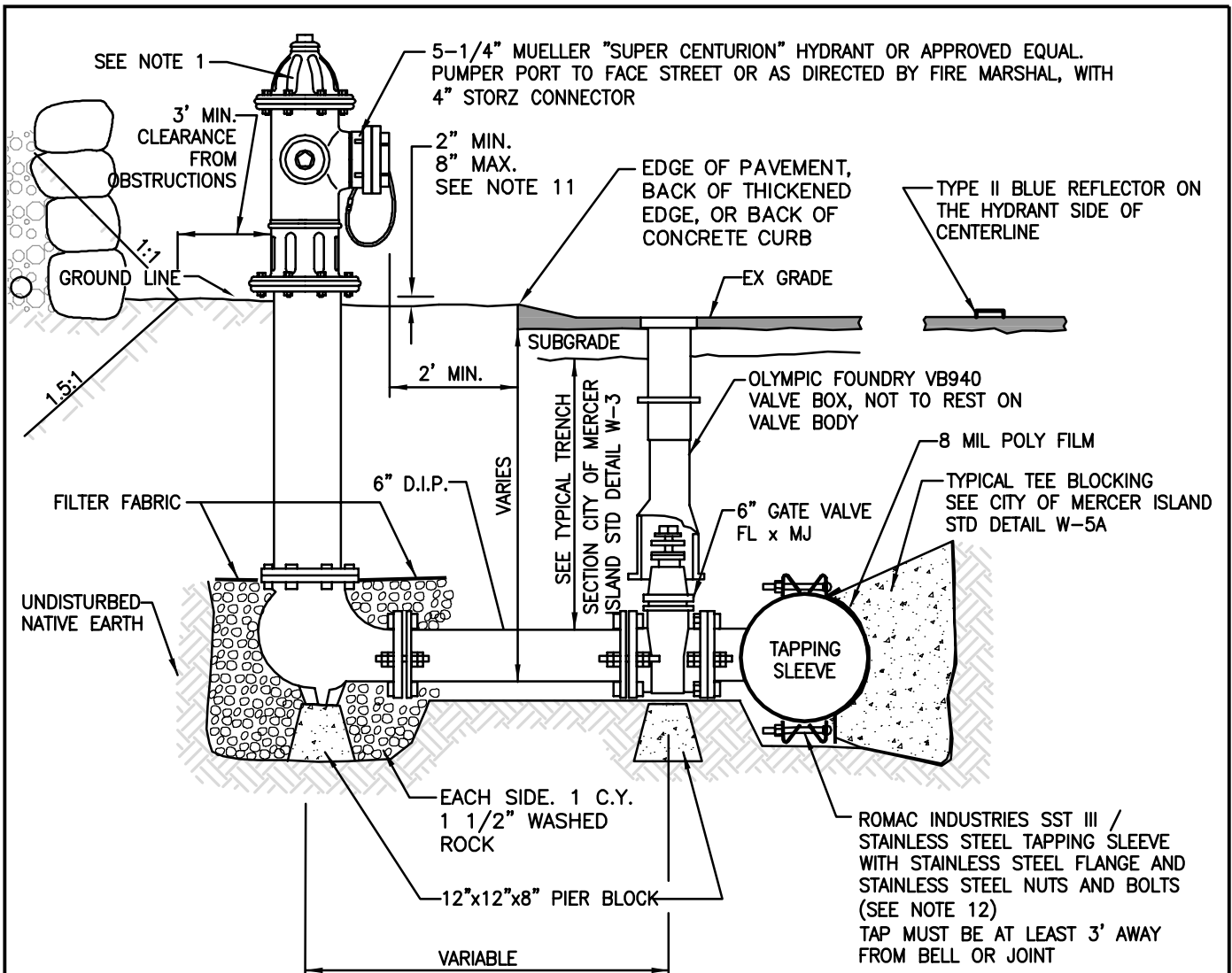

NOTE:

1. 1-5 1/4" M.V.O. HYDRANT WITH 2-2 1/2" N.T.S. M.J. INLET WITH LUGS, BRASS-TO-BRASS SUB-SEAT AND 1-4 1/2" PUMPER, SEATTLE STANDARD PIPE THREAD WITH 4" STORZ CONNECTOR ITEM NUMBER HPHA40-40-004/CAP SIZE 4.875-INCH BY 6-INCH.
2. WET TAP IS ALLOWED ONLY UPON CITY'S APPROVAL. NO SIZE ON SIZE WET TAPS.
3. NO DOMESTIC CONNECTIONS CAN BE MADE TO THE FIRE HYDRANT RUNS.
4. ANY FIRE HYDRANT RUN OVER 18 FEET IN LENGTH OF PIPE SHALL HAVE RESTRAINED JOINT GASKETS.
5. USE ROMA GRIP, OR APPROVED EQUAL, PIPE RESTRAINERS AT VALVE AND HYDRANT BASE.
6. HYDRANT SHALL BE PAINTED WITH 2 COATS OF FARWEST #250 HIGH GLOSS WHITE PAINT, OR APPROVED EQUAL, APPLIED WITH A PAINT BRUSH. DO NOT APPLY PAINT TO STORZ FITTING, BRASS PORT THREADS, OR BELOW SAFETY FLANGE.
7. BOLLARDS MAY BE USED TO PROTECT THE HYDRANT ONLY IN PARKING LOTS WHEN NO CURBS ARE PRESENT OR IN EXPOSED AREAS OF PARKING LOTS.
8. STRAIGHT PIPE TO HYDRANTS FROM MAIN, NO BENDS.
9. REMOVE CHAINS FROM HYDRANT CAPS.
10. VALVE AND HYDRANT MUST BE PLUMB.
11. THIS DISTANCE IS MEASURED FROM BOTTOM OF SAFETY FLANGE TO LEVEL OF FINISH GRADE BELOW HYDRANT.
12. TAPPING SLEEVE O.D. (OUTSIDE DIAMETER) RANGE MUST BE COMMENSURATE WITH PIPE O.D.

	CITY OF MERCER ISLAND	
	STANDARD DETAILS	
WATER		
FIRE HYDRANT ASSEMBLY -		
WET TAP INSTALLATION		
02-23-2021	NO SCALE	W-24A
REV DATE	APPROVED	

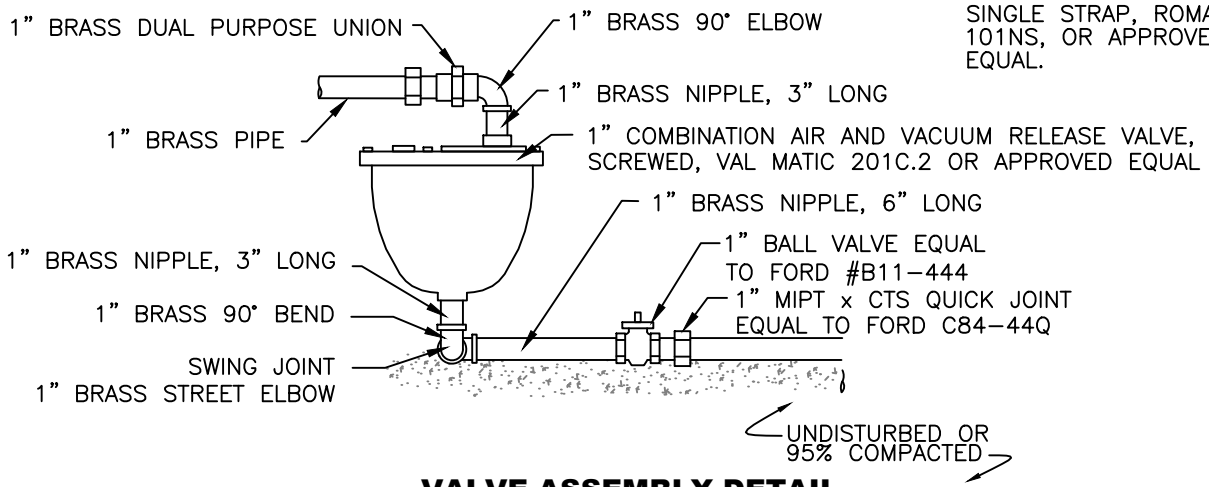
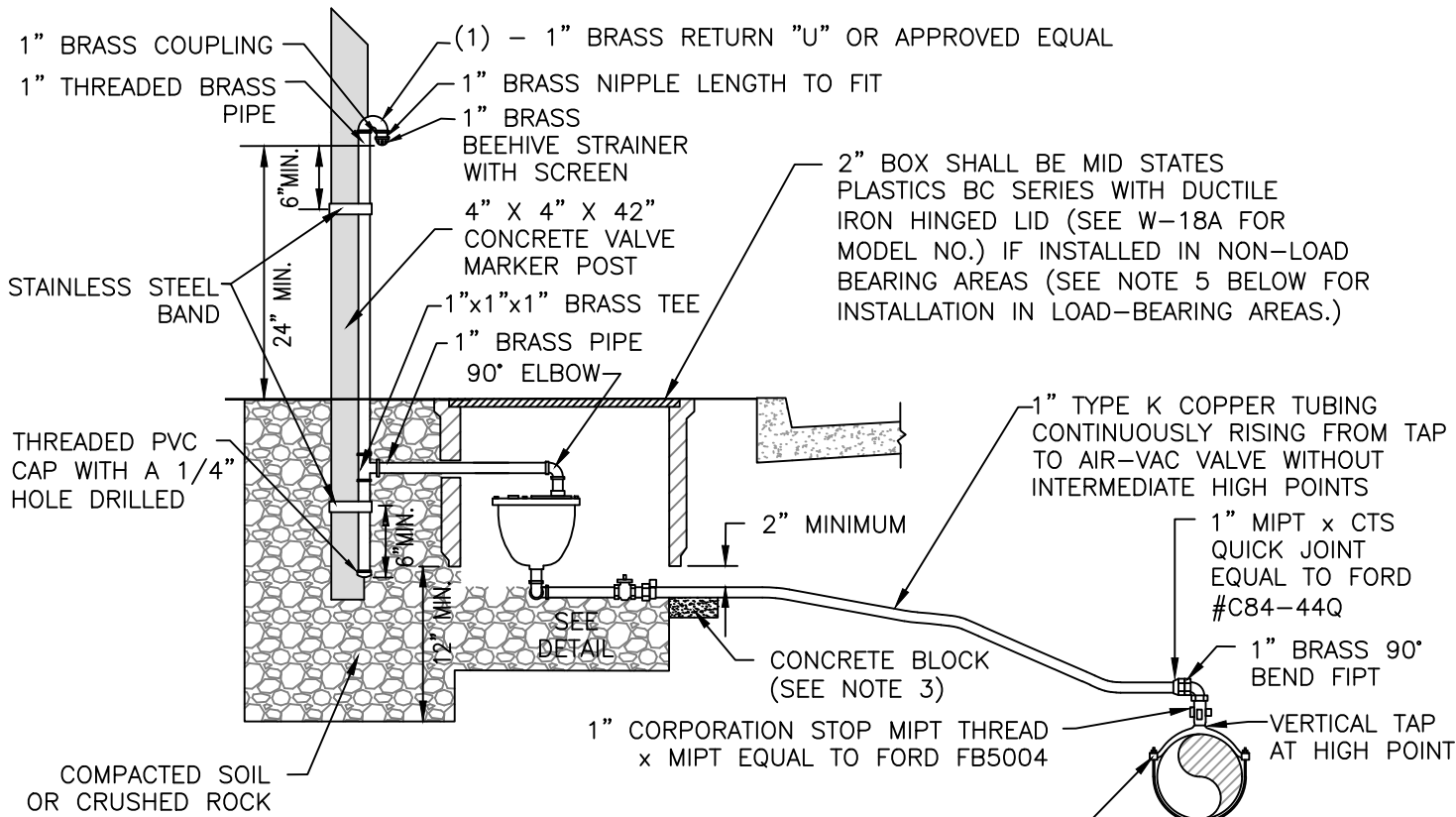

NOTES

VALVE ASSEMBLY DETAIL

1. ALL FITTINGS SHALL BE BRASS, ALL PIPE SHALL BE COPPER, UNLESS OTHERWISE SHOWN.
2. TAP FOR COMBINATION AIR AND VACUUM VALVE ASSEMBLY MUST BE INSTALLED AT HIGHEST POINT OF WATER MAIN. EXACT LOCATION OF ASSEMBLY TO BE DETERMINED BY CITY.
3. AT THE CITY INSPECTORS DISCRETION A CONCRETE BLOCK SHALL BE PLACED UNDER VALVE BOX TO KEEP BALL VALVE EXPOSED.
4. VALVE MARKER POST SHALL BE PAINTED WITH 2 COATS OF FARWEST #250 HIGH GLOSS WHITE PAINT, OR APPROVED EQUAL, APPLIED WITH A PAINT BRUSH.
5. IN LOAD BEARING LOCATIONS, OLYMPIC FOUNDRY SM-30, H-20 RATING, METAL METER BOX SHALL BE USED.



CITY OF MERCER ISLAND

STANDARD DETAILS

WATER

1" AIR & VACUUM VALVE ASSEMBLY

11-21-2017	NO SCALE	W-25
------------	----------	-------------

REV DATE							APPROVED
----------	--	--	--	--	--	--	----------

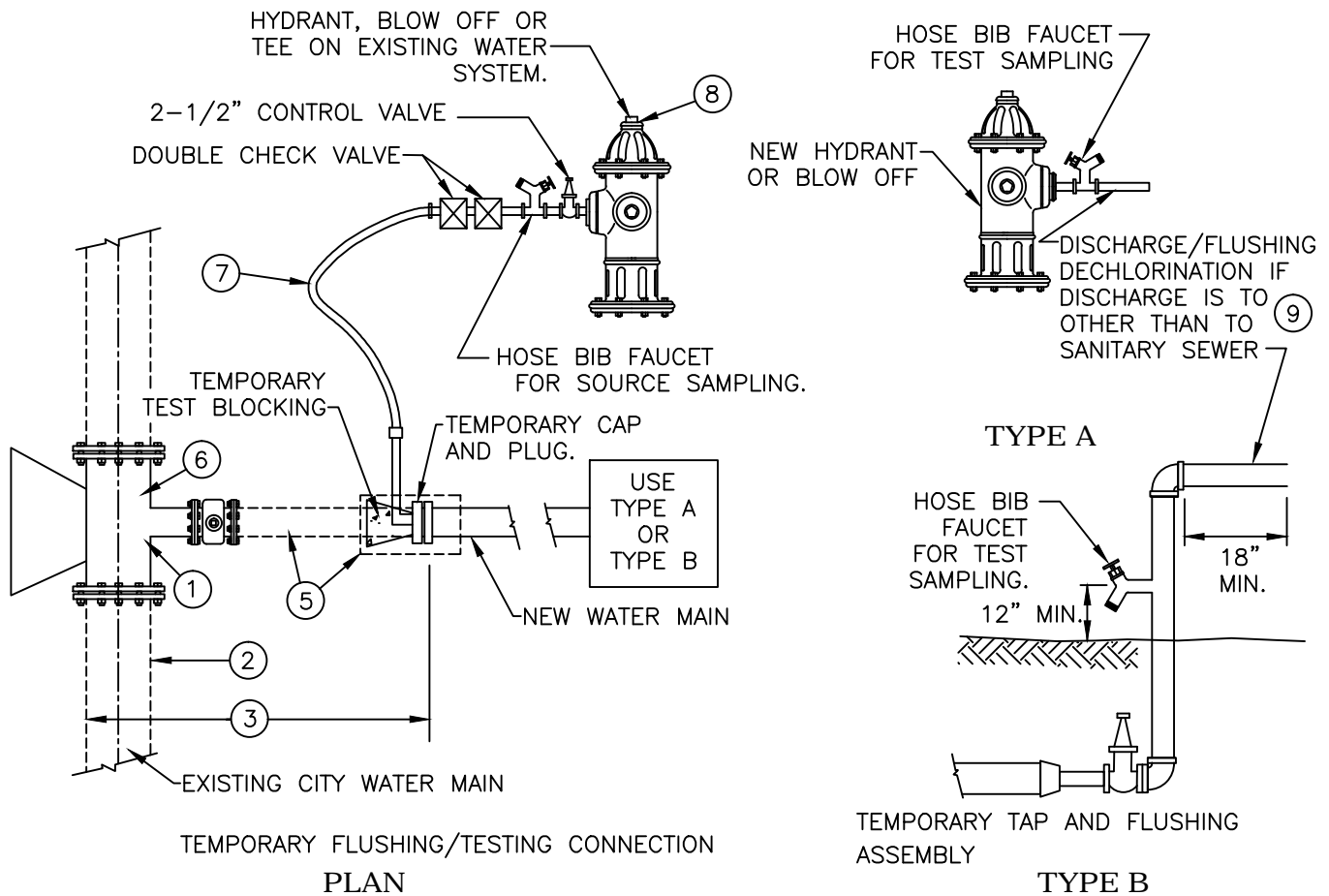

- ① CONTRACTOR TO DETERMINE ALIGNMENT, SIZE AND GRADE OF EXISTING FACILITIES PRIOR TO SHUTDOWN.
- ② ALL EXCAVATION, PIP, FITTINGS, MATERIALS, BACKFILL COMPACTION AND STREET RESTORATION ARE THE CONTRACTORS RESPONSIBILITY.
- ③ ALL MATERIALS TO BE ON SITE PRIOR TO SHUTDOWN OF EXISTING MAIN.
- ④ ALL PRESSURE TESTING, DISINFECTION, BACTERIA TESTING, TASTE TESTING AND NOTIFICATION OF RESIDENTS EFFECTED BY THE SHUTDOWN SHALL BE COMPLETED IN ACCORDANCE WITH SECTION 7, 8 & 9 OF DIVISION 9, WATER ENGINEERING STANDARDS, PRIOR TO CONNECTION TO THE CITY SYSTEM OF THE NEW WATERMAIN.
- ⑤ LONG PATTERN MECHANICAL JOINT, SLEEVE, WITH PIPE CUT TO FIT GAP – FURNISH AND INSERTED AT TIME OF CONNECTION.
- ⑥ TEE OR TAPPING TEE AND MATERIALS NECESSARY TO MAKE THE FINAL CONNECTION TO THE CITY WATER SYSTEM SHALL BE SUPPLIED AND INSTALLED BY THE CONTRACTOR.
- ⑦ CLEAN POTABLE WATER HOSE, WATER METER AND DCVA PROVIDED BY CITY, A RENTAL FEE IS REQUIRED.
- ⑧ HYDRANT PERMIT REQUIRED.
- ⑨ CHECK WITH SEWER DEPARTMENT BEFORE DISCHARGING INTO THE SANITARY SEWER SYSTEM. ALL CHLORINATED WATER MUST BE DISCHARGED INTO THE SANITARY SEWER SYSTEM, UNLESS DECHLORINATED FIRST.

NOTES

1. ALL FITTINGS TO BE DUCTILE IRON.
2. ALL EXCAVATION SHALL PROVIDE A MINIMUM OF 1' CLEAR AROUND PIPE AND FITTINGS.

	<p>CITY OF MERCER ISLAND STANDARD DETAILS WATER</p>	
<p>WATER MAIN FLUSHING</p>		
8-12-2009	NO SCALE	W-32
REV DATE		APPROVED

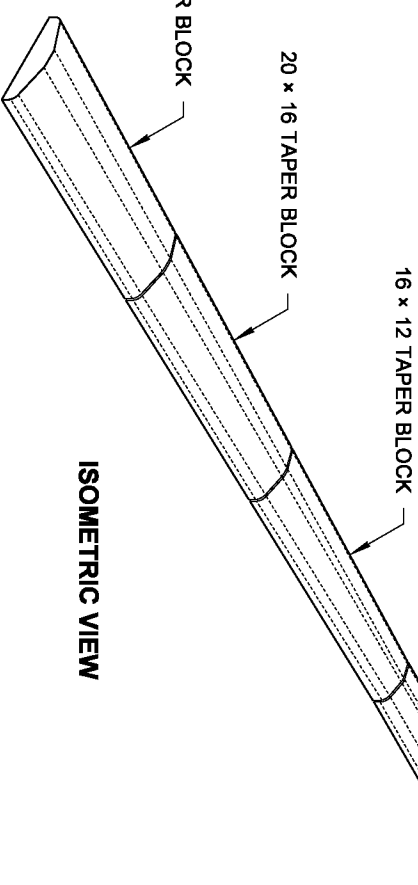
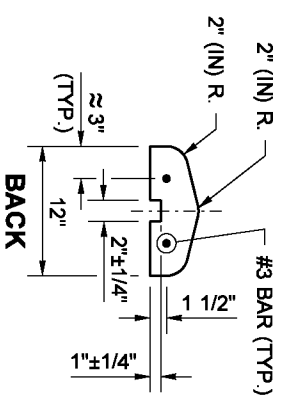
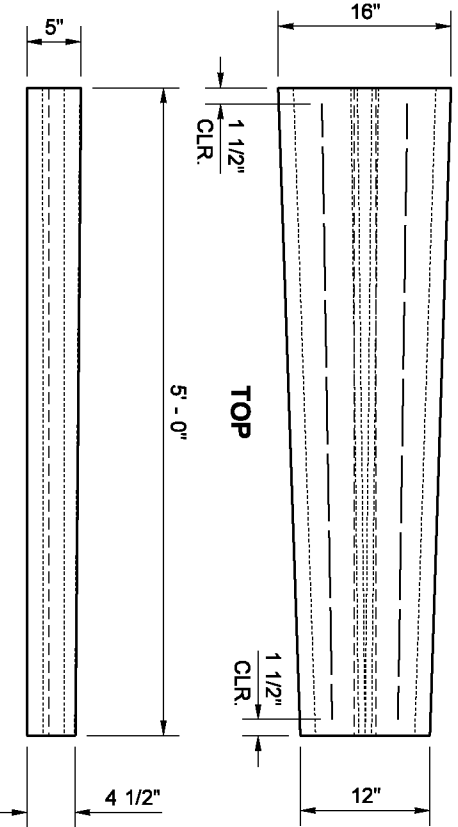
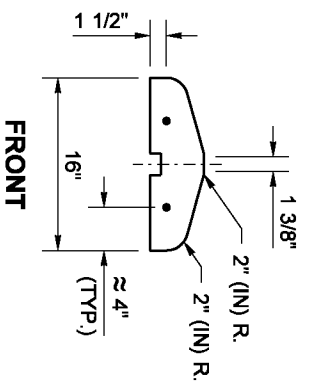
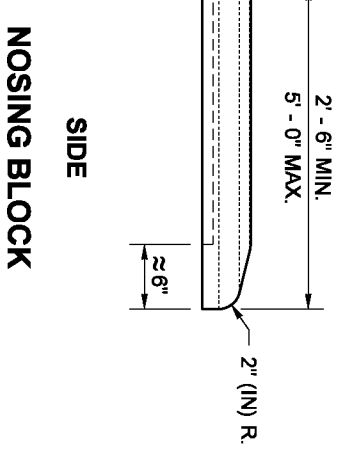
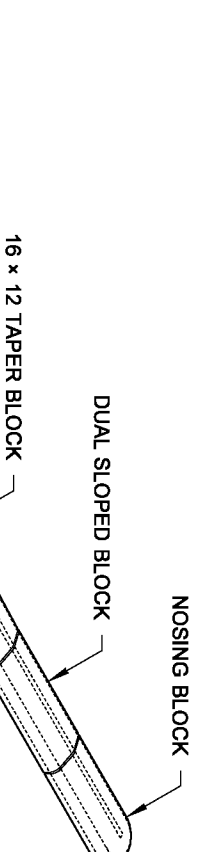
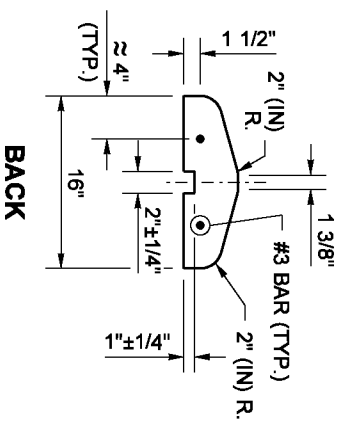
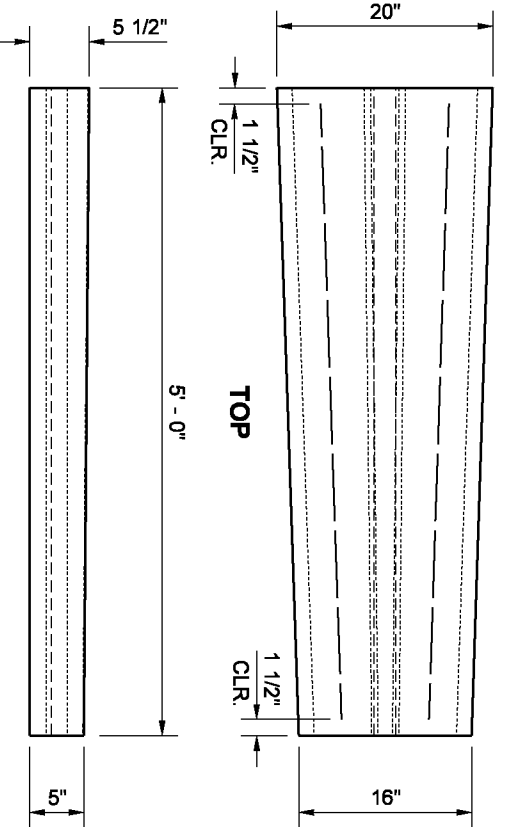
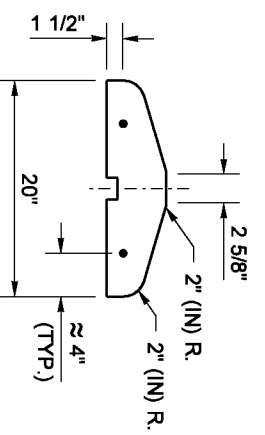
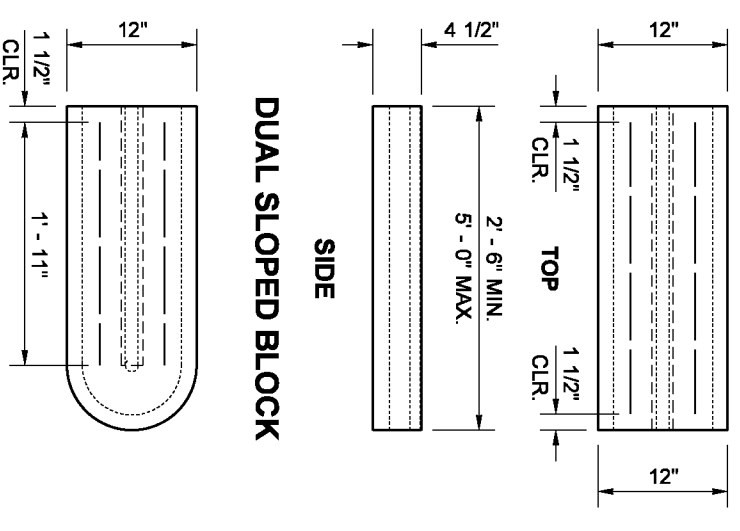
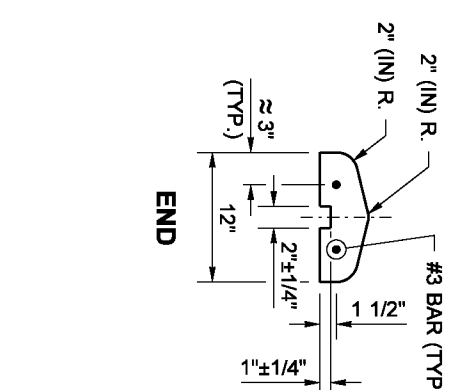
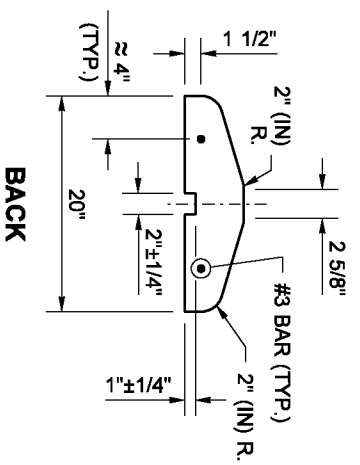
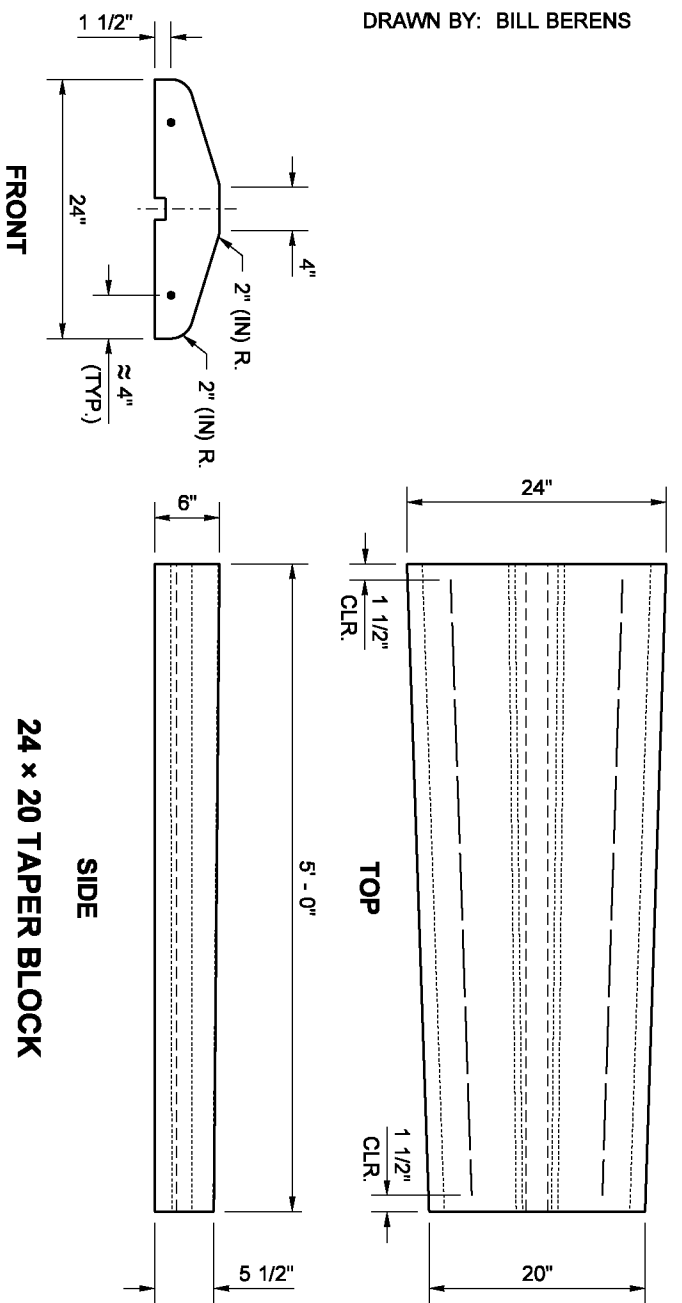

ISOMETRIC VIEW



PRECAST DUAL FACED SLOPED MOUNTABLE CURB STANDARD PLAN F-10.64-03

SHEET 1 OF 1 SHEET

APPROVED FOR PUBLICATION



- NOTES**
1. The dual faced curb may be constructed by using two precast sloped mountable curbs (longitudinal halves) so long as the installation is consistent with the dimensions shown in the plan.
 2. Reinforcing steel shall conform to **Standard Specification 9-07**.

DRAWN BY: LISA CYFORD

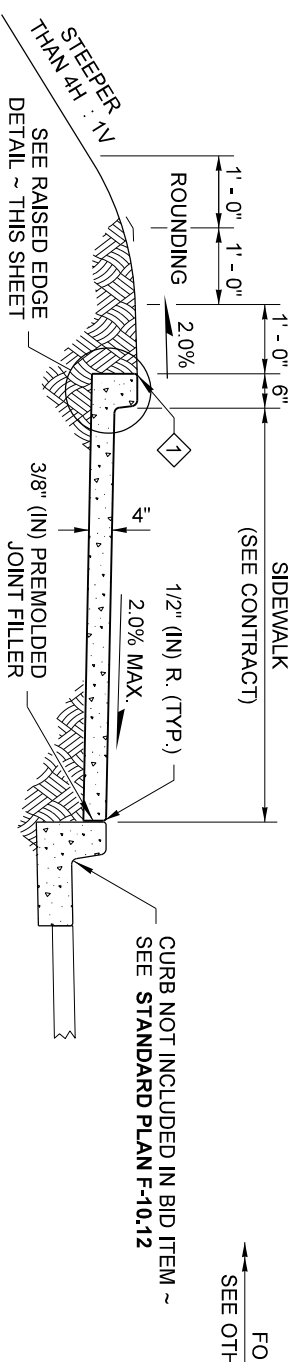

WITH RAISED EDGE

1 FINISHED GRADE 1" (IN) BELOW TOP OF CONCRETE SURFACE

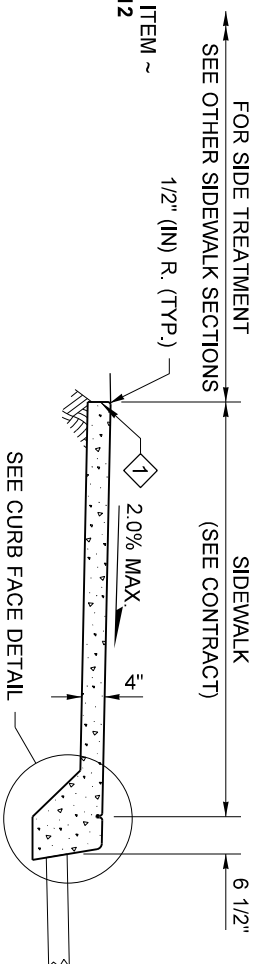

NOTE

1. Gratings, Access Covers, Junction Boxes, Cable Vaults, Pull Boxes and other appurtenances within the sidewalk must have slip resistant surfaces, be flush with surface, and match grade of the sidewalk.

MONOLITHIC CEMENT CONCRETE CURB AND SIDEWALK

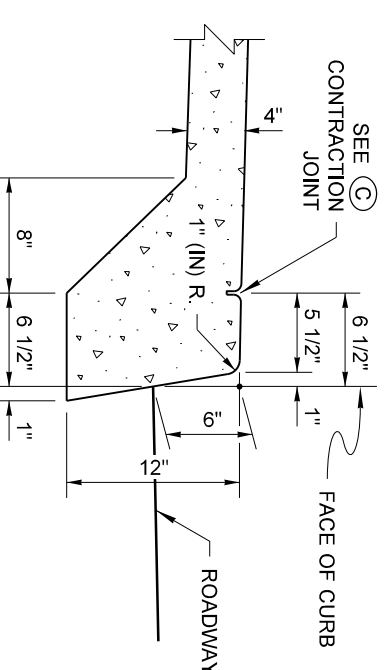

CURB FACE DETAIL

EXTEND SIDEWALK TRANSVERSE EXPANSION JOINTS TO INCLUDE CURB (FULL DEPTH)

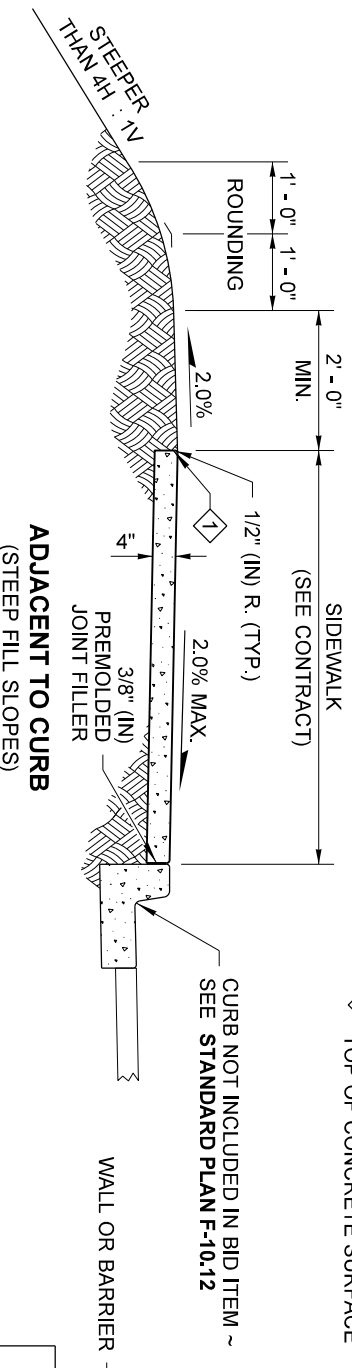

ADJACENT TO CURB (STEEP FILL SLOPES)

WALL OR BARRIER

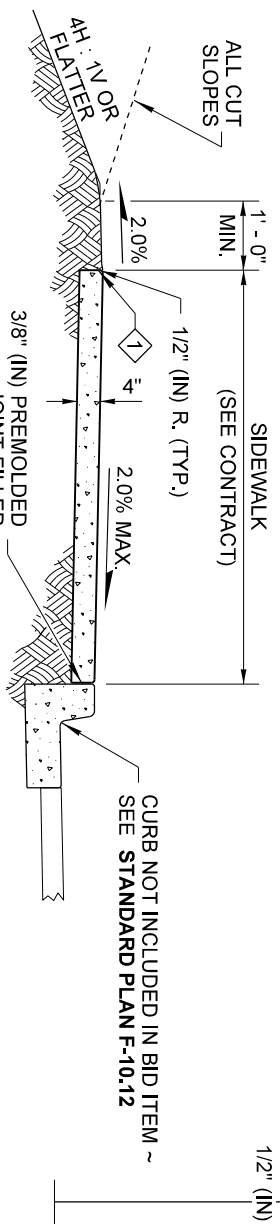

ADJACENT TO CURB

SIDEWALK ADJACENT TO WALL DETAIL

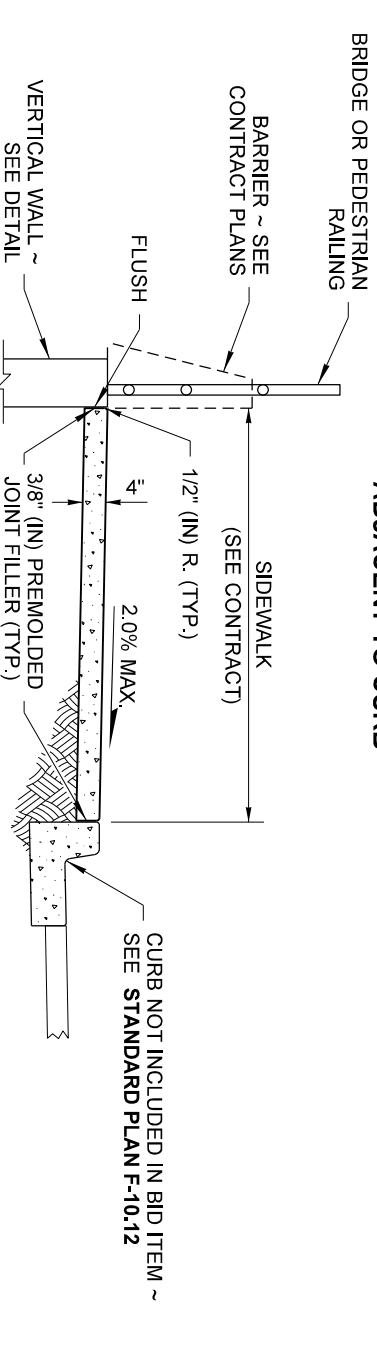
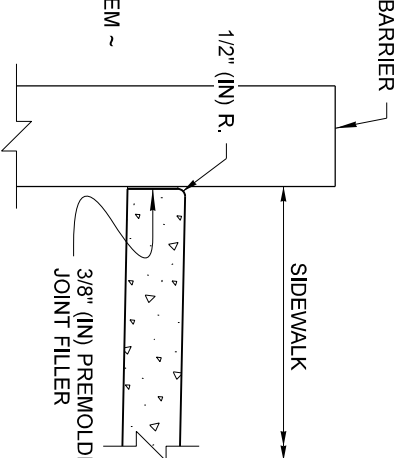

ADJACENT TO CURB AND RAILING OR WALL

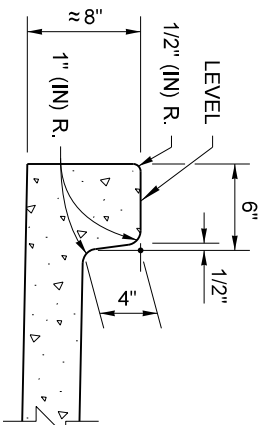

RAISED EDGE DETAIL

EXTEND SIDEWALK TRANSVERSE JOINTS TO INCLUDE RAISED EDGE

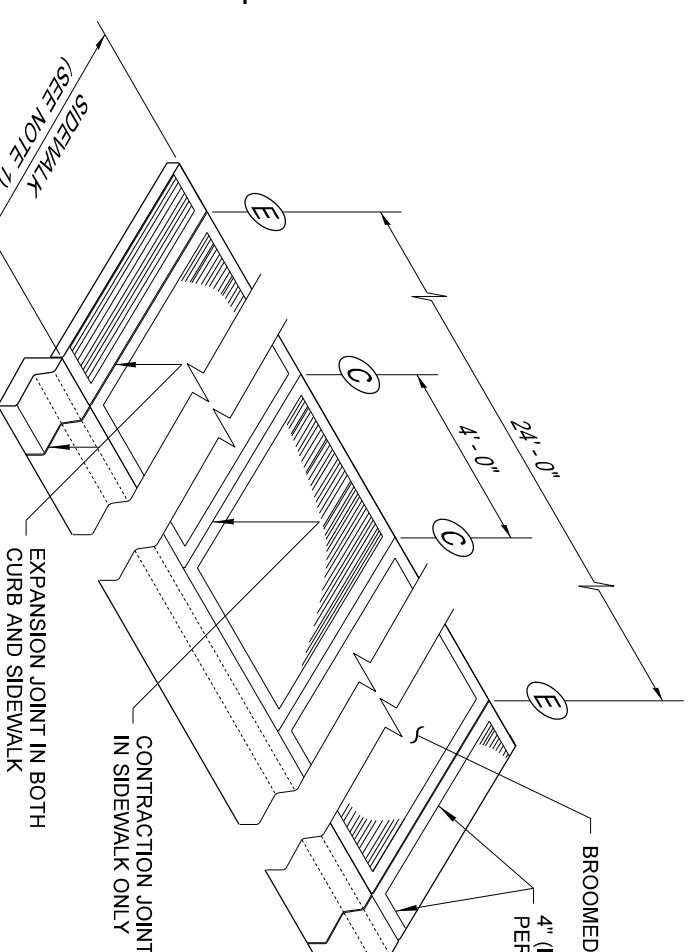

ISOMETRIC VIEW JOINT AND FINISH DETAIL

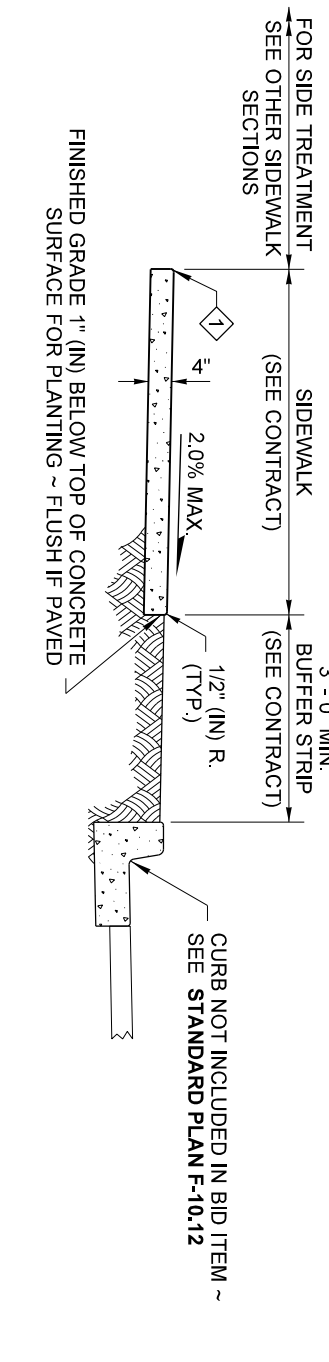

ADJACENT TO BUFFER STRIP

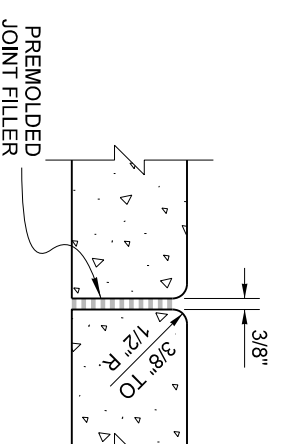

EXPANSION JOINT

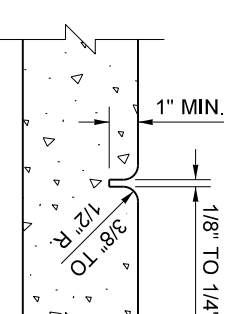

CONTRACTION JOINT

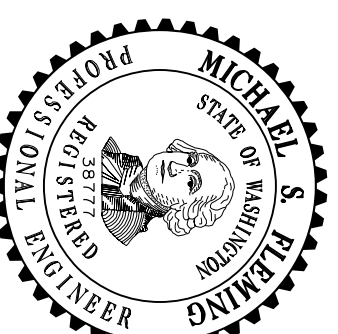

Michael S Fleming
 Digitally signed by Michael S Fleming
 Date: 2020.09.24 07:40:16 -07'00'
CEMENT CONCRETE SIDEWALK

STANDARD PLAN F-30.10-04

SHEET 1 OF 1 SHEET

APPROVED FOR PUBLICATION
 Date: 2020.09.25
 15:43:50 -07'00'
 STATE DESIGN ENGINEER
 Washington State Department of Transportation