

CITY OF MERCER ISLAND

KING COUNTY, WASHINGTON



2023 RESIDENTIAL STREET OVERLAYS

Project Number: 23-16



BID SUBMITTAL

May 2023

5/5/2023

FOREWORD

THE ITEMS WHICH MAKE UP THE CONTRACT DOCUMENTS ARE AS FOLLOWS:

DIVISION 0 - NOTICES, BIDDING REQUIREMENTS, AND AGREEMENT FORMS

Notices, Bidding Requirements, and Agreement Forms have been copied and bound together with the remainder of the Contract Documents to facilitate the bidder's submittal of this proposal and other required documents.

DIVISION 1-9 - SPECIAL PROVISIONS

2023 Edition of "Standard Specifications for Road, Bridge, and Municipal Construction" prepared by the Washington State Chapter, American Public Works Association (APWA), and the Washington State Department of Transportation (Standard Specifications) and amendments.

APPENDIX

- A. Prevailing Wage Rates
- B. Mercer Island Traffic Standard Details

PLANS (Bound Separately)

TABLE OF CONTENTS

DIVISION 0

NOTICES

- Advertisement for Bids N-1
- Instructions to Bidders N-2
- Bidder's Check List N-10

BIDDING REQUIREMENTS

- Non-Collusion Certificate A-1
- Bid Form A-2
- Proposal Signature Sheet A-12
- Bid Guaranty Bond A-13
- Bidder's Qualifications Certificate A-14

AGREEMENT FORMS (Submit within 10 calendar days of the Notice of Award)

- Public Works Contract B-1
- Contract Change Order Agreement B-10
- Performance Bond B-12
- Payment Bond B-13
- Retainage Agreement B-14

DIVISION 1-9

SPECIAL PROVISIONS

INTRODUCTION TO THE SPECIAL PROVISIONS	SP-1
DIVISION 1 – GENERAL REQUIREMENTS	SP-2
1-01 Definitions and Terms	SP-2
1-02 Bid Procedures and Conditions	SP-4
1-03 Award and Execution of Contract	SP-8
1-04 Scope of Work	SP-9
1-05 Control of Work	SP-10
1-07 Legal Relations and Responsibilities to the Public	SP-13
1-08 Prosecution and Progress	SP-18
1-09 Measurement and Payment	SP-22
1-10 Temporary Traffic Control	SP-24
DIVISION 2 – EARTHWORK	SP-25
2-01 Clearing, Grubbing, and Roadside Cleanup	SP-25
2-02 Removal of Structures and Obstructions	SP-25
2-03 Roadway Excavation and Embankment	SP-28
2-06 Subgrade Preparation	SP-28

TABLE OF CONTENTS (Continued)

	DIVISION 3 – PRODUCTION FROM QUARRY AND PIT SITES AND STOCKPILING	SP-30
3-01	Production from Quarry and Pit Sites	SP-30
	DIVISION 4 – BASES	SP-31
4-04	Ballast and Crushed Surfacing	SP-31
	DIVISION 5 - SURFACE TREATMENTS AND PAVEMENTS	SP-32
5-04	Hot Mix Asphalt	SP-32
	DIVISION 7 – DRAINAGE STRUCTURES, STORM SEWERS, SANITARY SEWERS, WATER MAINS, AND CONDUITS	SP-36
7-00	General Matters	SP-36
7-05	Manholes, Inlets, Catch Basins, and Drywells	SP-36
7-07	Cleaning Existing Drainage Structures	SP-38
7-12	Valves for Water Mains	SP-38
7-15	Service Connections	SP-39
	DIVISION 8 – MISCELLANEOUS CONSTRUCTION	SP-40
8-01	Erosion Control and Water Pollution Control	SP-40
8-02	Roadside Restoration	SP-43
8-09	Raised Pavement Markers	SP-44
8-13	Monument Cases	SP-44
8-14	Cement Concrete Sidewalks	SP-45
8-22	Pavement Markings	SP-45
8-23	Temporary Pavement Markings	SP-46
8-26	Edge Restoration	SP-46
	DIVISION 9 – MATERIALS	SP-48
9-03	Aggregates	SP-48

APPENDIX

- A. Prevailing Wage Rates
- B. Mercer Island Traffic Standard Details

PLANS (Bound Separately)

NOTICES

Advertisement for Bids City of Mercer Island

Project Title: 2023 Residential Street Overlays
Bid Number: 23-16
Engineers Estimated Cost (range): \$950,000 to \$1,050,000

Sealed bids will be received, not sent, electronically by the city until 2:00 PM on May 23, 2023. Bidders shall submit their bids in PDF format to the Public Works email address at publicworks@mercerisland.gov. There will be no public bid opening for this project; bid results will be posted on the City's webpage at: <https://www.mercerisland.gov/rfps>.

Work to be performed under this contract includes, but is not limited to furnishing all labor, equipment, and materials necessary for asphalt overlay of approximately 1.5 miles of residential streets, consisting of: temporary traffic control, pavement repairs, asphalt planing, full width and full depth asphalt pavement removal, roadway widening, hot mix asphalt paving, shoulder restoration, utility adjustments, and pavement markings.

A single contract is to be awarded to the responsible bidder submitting the lowest responsive bid. The City reserves the right to reject any and all bids and to waive minor irregularities.

Plans, specifications, addenda, and bidders list are available on-line through Builders Exchange of Washington, Inc. at <http://www.bxwa.com>. Click on "Posted Projects", "Public Works", "City of Mercer Island", "Projects Bidding". Builders Exchange manages the official bidders list. Bidders are encouraged to register in order to receive automatic email notification of future addenda and to be placed on the official bidders list.

Plans and specifications are also available at the City of Mercer Island website <https://www.mercerisland.gov/rfps>. Addenda may not be available or updated on this website.

A bid deposit in the amount of five percent (5%) of the bid total price must accompany each bid.

Bidders questions are to be directed to Ian Powell, Street Engineer, by email at ian.powell@mercerisland.gov, or by phone at 206-939-3000.

The City of Mercer Island, in accordance with Title VI of the Civil Rights Act of 1964, 78 Stat. 252, 42 U.S.C. 2000d to 2000d-4 and Title 49, Code of Federal Regulations, Department of Transportation, Subtitle A, Office of the Secretary, Part 21, Nondiscrimination in Federally-assisted programs of the Department of Transportation issued pursuant to such Act, hereby notifies all bidders that it will affirmatively ensure that in any contract entered into pursuant to this advertisement, disadvantaged business enterprises as defined at 49 CFR Part 23 will be afforded full opportunity to submit bids in response to this invitation and will not be discriminated against on the grounds of race, color, national origin, or sex in consideration for an award.

Andrea Larson, City Clerk

Published: Seattle Daily Journal of Commerce – May 8, 2023 & May 10, 2023

INSTRUCTIONS TO BIDDERS

1. ELIGIBILITY TO BID:

It is the intent of the City to award a contract to the low responsible bidder. Before award, the bidder must meet the following bidder responsibility criteria to be considered a responsible bidder. To be eligible to bid, each Bidder must:

- A. At the time of bid submittal, have a current certificate of registration as a contractor in compliance with chapter 18.27 RCW; and
- B. Have a current Washington Unified Business Identifier (UBI) number; and
- C. If applicable:
 - i. Have Industrial Insurance (workers' compensation) coverage for the bidder's employees working in Washington, as required in Title 51 RCW; and
 - ii. Have a Washington Employment Security Department number, as required in Title 50 RCW; and
 - iii. Have a Washington Department of Revenue state excise tax registration number, as required in Title 82 RCW; and
- D. Not be disqualified from bidding on any public works contract under RCW 39.06.010 or 39.12.065(3); and
- E. Within the three-year period immediately preceding the date of the bid solicitation, not have been determined by a final and binding citation and notice of assessment issued by the department of labor and industries or through a civil judgment entered by a court of limited or general jurisdiction to have willfully violated, as defined in RCW 49.48.082, any provision of chapter 49.46, 49.48 or 49.52 RCW.

A contract shall only be awarded to a Bidder that demonstrates to the City's satisfaction that the Bidder is qualified to perform the Work and is, therefore, a responsible bidder.

2. SUBCONTRACTOR RESPONSIBILITY CRITERIA:

The Bidder must verify responsibility criteria for each first-tier subcontractor, and each subcontractor of any tier that hires other subcontractors must verify responsibility criteria for each of its subcontractors. Upon request of the City the Bidder shall promptly provide documentation to the City demonstrating that the subcontractor(s) meets the subcontractor responsibility criteria below. The requirements of this section apply to all subcontractors regardless of tier.

At the time of subcontract execution, the Bidder shall verify that each of its first-tier subcontractors meets the following bidder responsibility criteria:

- A. Have a current certificate of registration in compliance with chapter 18.27 RCW; and
- B. Have a current Washington Unified Business Identifier (UBI) number; and
- C. If applicable:

- i. Have Industrial Insurance (workers' compensation) coverage for the subcontractor's employees working in Washington, as required in Title 51 RCW; and
 - ii. Have a Washington Employment Security Department number, as required in Title 50 RCW; and
 - iii. Have a Washington Department of Revenue state excise tax registration number as required in Title 82 RCW; and
 - iv. Have an electrical contractor license, if required by Chapter 19.28 RCW; and
 - v. Have an elevator contractor license, if required by Chapter 70.87 RCW; and
- D. Not be disqualified from bidding on any public works contract under RCW 39.06.010 or 39.12.065 (3); and

3. EXAMINATION OF PLANS, SPECIFICATIONS AND SITE:

Each bidder is instructed to examine the Plans, Specifications, Addenda, the site of the proposed improvements, and conduct any other examination and investigation which the bidder may desire to make as to the accuracy of the nature of the work and the difficulties to be encountered. The Bidder shall be responsible for all costs associated with these additional examinations including all restoration work and damages which may be a result of such investigation. Bidders shall consider Federal, State, and local laws and regulations that may affect cost, progress, or performance of the work.

4. ADDITIONAL INFORMATION:

All questions about the meaning or intent of the Contract Documents are to be directed to Ian Powell, Street Engineer, in writing by email at ian.powell@mercerisland.gov.

Interpretations or clarifications considered necessary by the City in response to such questions will be issued by Addenda mailed or delivered to all parties recorded by the Engineer or City as having received the Contract Documents. Questions received less than ten (10) days prior to the date for opening of Bids may not be answered. Only questions answered by formal written Addenda will be binding. Oral and other interpretations or clarifications will be without legal effect.

5. WAGES:

This Contract is subject to Chapters 39.12 and 49.28 RCW, amendments thereto and regulations issued thereunder, relating to prevailing wages, benefits and other requirements. Bidders shall examine and be familiar with such requirements. No claim for additional compensation will be allowed which is based upon a lack of knowledge or a misunderstanding of any such requirements by the Bidder or a failure to include in Bidder's price adequate increases in such wages during the performance of this Contract. A copy of the most recent prevailing wage schedule is in the Appendix of the specifications. Current prevailing wage rates for King County can be obtained from the Washington State Department of Labor and Industries at www.lni.wa.gov/TradesLicensing/PrevWage/.

6. PROGRESS AND COMPLETION:

Time is of the essence for this Project. Progress and completion of the Work shall comply with all requirements herein, and intermediate and final completion dates as may be set forth in the specifications. The submission of a bid constitutes the Bidder's acknowledgement that such progress and completion requirements have been taken into account in formulating a price for this Work.

7. PREVENTION OF ENVIRONMENTAL POLLUTION AND PRESERVATION OF PUBLIC NATURAL RESOURCES:

If awarded the Contract, the Bidder shall fully comply with all such environmental protection laws, ordinances and regulations dealing with prevention and environmental pollution and the preservation of public natural resources that may be applicable to this Project. The cost of such compliance shall be included in the bid prices.

8. BID FORM:

The Bid Form is included in the Contract Documents. The Bid Form must be completed in ink. Bids that contain omissions, erasures or irregularities of any kind may be rejected. Any qualification, addition, limitation or provision attached to or contained in a bid may render the bid non-responsive and not eligible for award. No oral, facsimile, telegraphic or telephonic bids or modifications will be considered.

All bids shall be signed by the Bidder, or the Bidder's authorized representative. If the bid is made:

- A. By an individual, the Bidder's name, signature, and address must be shown;
- B. By a partnership or joint venture, it shall contain the names of each partner, the mailing address of the partnership or joint venture and shall be signed in the firm name, followed by the signature of the person signing, indicating that person's position in the partnership or joint venture;
- C. By a corporation or limited liability company ("LLC"), the name of the state under the laws of which the corporation or LLC is chartered, the name and post office address of the corporation or LLC and the title of the person who signs on behalf of the corporation or LLC must be shown.

Upon the City's request, the Bidder shall provide copies of the articles of incorporation, bylaws, resolutions of board of directors, partnership papers, joint venture agreements, and any other documents evidencing the legal status of the Bidder and the authority of the Bidder's officer or representative who signed the bid on behalf of the Bidder.

The City is not responsible for any cost incurred in responding to this Call for Bids.

9. ACKNOWLEDGEMENT OF ADDENDA:

Each Bidder shall include on the Bid Form specific acknowledgment of receipt of each Addendum issued by the City during the bidding period. If the Bidder does not specifically acknowledge each addendum, the City may reject the bid as non-responsive unless the City determines from delivery records or from inclusion of information in the bid of information contained in the addenda that the Bidder received constructive notice of the addenda.

10. BID SECURITY:

The Bid shall be accompanied by a bid deposit in the amount equal to at least 5% of the Total Bid Price. The bid deposit shall be in one of the following formats and made payable to the City:

- A. A bid guaranty bond, in accordance with and using a form acceptable to the City which contains provisions substantially similar to those in the bid bond form included with the Contract

Documents, duly completed by a guaranty company authorized to carry on business in the state of Washington; or

- B. A postal money order, a certified check, or cashier's check drawn upon a banking institution with a branch office in the state of Washington.

The surety signing the bid guaranty bond shall be registered with the Washington State Insurance Commissioner, and the surety's name shall appear in the current Authorized Insurance Company List in the State of Washington published by the Office of the Insurance Commissioner. A Power of Attorney must accompany the bid guaranty bond and must appoint the surety's true and lawful attorney-in-fact to make, execute, seal and deliver the bid guarantee bond. Failure to submit the required bid security with the Bid shall render the bid non-responsive and the Bid shall be rejected.

11. NON-COLLUSION:

Each bid shall be accompanied by a signed Non-Collusion Declaration in accordance with, and using the form provided by the City. Failure to submit a signed Declaration with the Bid shall render the bid non-responsive and the Bid shall be rejected.

More than one Bid from an individual, firm, partnership, corporation, or association under the same or different names will not be considered. If the City believes that any Bidder is interested in more than one Bid for the work contemplated, all Bids in which such Bidder is interested will be rejected. If the City believes that collusion exists among the Bidders, all Bids will be rejected.

12. DELIVERY OF BID:

Bids will be received electronically. See first paragraph under Advertisement for Bids. The City will not consider bids received after the time fixed for opening bids in the Advertisement for Bids.

The submission of a Bid will constitute an incontrovertible representation by the Bidder that the Bidder has complied with every requirement of these instructions, that without exception the Bid is premised upon performing the work required by the Contract Documents and such means, methods, techniques, sequences, or procedures of construction as may be indicated in or required by the Contract Documents, and that the Contract Documents are sufficient in scope and detail to indicate and convey understanding of all terms and conditions for performance of the work.

13. MODIFICATION OF BID:

A modification of a Bid will be considered only if the modification is received prior to the time announced for the opening of Bids. All modifications shall be made in writing executed and submitted in the same form and manner as the original Bid.

14. RETURN OF BID SECURITY:

After the bid prices have been compared, the City may return the bid security if, in the City's judgment, the Bidder would not be considered for award. All other Proposal Guarantees will be held until the Contract and the Performance Bond of the successful bidder have been executed.

15. EVALUATION OF BIDS AND BID ERRORS:

After opening the Bids, the City will check them for correctness of extensions of the prices per unit and the total price. If a discrepancy exists between the price per unit and the extended amount of any bid item, the price per unit will control. The total of extensions, corrected where necessary, will be used by the City for award purposes.

Irregular Bids:

- A. A Bid will be considered irregular and will be rejected if:
 - i. The authorized Bid Form furnished by the City is not used or is materially altered;
 - ii. The completed Bid Form contains any unauthorized additions, deletions, alternate bids, or conditions;
 - iii. The bidder adds provisions reserving the right to reject or accept the Award, or enter into the Contract;
 - iv. A price per unit cannot be determined from the Bid Form;
 - v. The Bid Form is not properly executed;
 - vi. An executed non-collusion certificate is not provided; or
 - vii. Proper bid security does not accompany the Bid.

- B. A Bid may be considered irregular and may be rejected if:
 - i. The Bid Form does not include a unit price for every Bid item;
 - ii. Any of the unit prices are excessively unbalanced (either above or below the amount of a reasonable Bid) to the potential detriment of the City;
 - iii. Receipt of Addenda is not acknowledged;
 - iv. A member of a joint venture or partnership and the joint venture or partnership submit Bid Forms for the same project (in such an instance, both Bids may be rejected); or
 - v. If Bid Form entries are not made in ink.

Bids will be evaluated by the City to determine which bid is the apparent lowest, responsive bid.

Bid results will be posted on the City's website at www.mercergov.org.

The City, in its sole discretion, reserves the right to waive minor bid errors, informalities, and immaterial irregularities when it is in the City's best interest to do so.

16. EVALUATION OF BIDDER RESPONSIBILITY:

A Contract shall only be awarded to a Bidder that demonstrates to the City's satisfaction that the Bidder is qualified to perform the Work and is, therefore, a responsible bidder.

- A. Bidder Responsibility Criteria. To be determined responsible, the Bidder must, in addition to satisfying the bidder responsibility criteria listed in Section 1. ELIGIBILITY TO BID above:
 - i. Have adequate financial resources to perform the contract, or the ability to obtain them;
 - ii. Have a satisfactory performance record;
 - iii. Have a satisfactory record of integrity and business ethics;

- iv. Have the necessary production, construction, and technical equipment and facilities or the ability to obtain them;
- v. Be otherwise qualified and eligible to receive an award under applicable laws and regulations;
- vi. Be in compliance with training requirements in RCW 39.04.350(1)(f); and
- vii. Provide a statement in accordance with RCW 9A.72.085 verifying compliance with responsible bidder criteria requirement of RCW 39.04.350(1)(g).

B. Reference Checking. To assist the City in the review of the Bidder's qualifications, the Bidder shall, within five (5) days of being requested to do so by the City, provide the following information:

- i. Past Experience in Similar Projects. Provide a list of all construction contracts (whether completed or in progress) entered into or performed by the Bidder within the past five (5) years for projects similar in scope, time and complexity to the work called for under this Contract. Provide the names of the contracts, the contract price, and the names and phone numbers of the owners.
- ii. References. Provide a list of five (5) references. References will be asked to rate performance on the following items: overall project performance; acceptable experience and technical knowledge; effective coordination of subcontractors; ability to coordinate and work with utility companies and governmental entities; responsiveness to owner requests; attention to safety; quality and timeliness of submittals, change order proposals, project schedule, schedule updates and other applicable paperwork.

If the Bidder is a joint venture, the Bidder shall submit information for the joint venture if the members have worked together in the past and also information about each member of the joint venture. The Joint Venture Agreement shall be included in the submission.

If the Bidder fails to supply information requested concerning responsibility within the time and the manner specified, the City may base its determination of responsibility upon any available information related to the responsibility criteria or may find the Bidder is not responsible.

The City reserves the right to inspect records, reports and other information which may be maintained by or for the Bidder to the extent necessary, as determined by the City to verify, clarify or otherwise consider the information provided by the Bidder.

17. DETERMINATION OF NON-RESPONSIBILITY:

If the City determines a Bidder to be not responsible, the City will provide, in writing, the reasons for the determination. The Bidder may appeal the determination within ten (10) days of its receipt of the City's determination of non-responsibility by presenting additional information to the City. The City shall consider the additional information before issuing its final determination. If the City's final determination affirms that the Bidder is not responsible, the City shall not execute a contract with any other bidder until two (2) business days after the Bidder determined to be not responsible has received the final determination.

18. CONTRACT AWARD:

If a Contract is awarded, the City will award the contract to the responsible bidder that submits the lowest total responsive bid for the schedule(s) selected by City after bid opening and prior to award.

If the Contract is to be awarded, City will give the successful Bidder a Notice of Award within sixty (60) days after the day of the Bid opening. No other act of the City or others will constitute acceptance of a Bid.

The City reserves the right to request bidders to extend the effective period of their bids.

19. REJECTION OF ALL BIDS:

The City reserves the right to reject any or all Bids at any time up to actual execution of the Public Works Contract, even if there has been an award of the Contract.

Any or all Bids will be rejected if the City has reason to believe that collusion exists among the Bidders.

20. EXECUTION OF PUBLIC WORKS CONTRACT:

The Bidder to whom award is made shall execute a written Public Works Contract with the City on the form provided, shall secure all insurance, and shall furnish all certificates, endorsements and bonds required by the Contract Documents within ten (10) calendar days after receipt of the forms from the City. Failure or refusal to execute the Public Works Contract as herein provided or to conform to any of the stipulated requirements in connection therewith shall be just cause for annulment of the award and forfeiture of the Bid security. If the lowest responsive, responsible Bidder refuses or fails to execute the Public Works Contract, the City may award the Contract to the second lowest responsive, responsible Bidder. If the second lowest responsive, responsible Bidder refuses or fails to execute the Public Works Contract, the City may award the contract to the third lowest responsive, responsible Bidder. On the failure or refusal of such second or third lowest Bidder to execute the Agreement, each such Bidder's Bid securities shall be likewise forfeited to the City.

21. BID PROTEST PROCEDURES:

- A. Form of Protest. In order to be considered, a Protest shall be in writing, addressed and delivered to the attention of the project manager at the City of Mercer Island, 9611 SE 36th Street, Mercer Island, Washington 98040. The Protest shall include the following:
 - i. The name, address, and phone number of the Bidder protesting, or the authorized representative of the Bidder;
 - ii. A complete, detailed statement of all grounds for protest, supporting authority, and any supporting documentation. Supplemental information will not be considered unless the supplementation contains information not available at the time of protest;
 - iii. The specific ruling or relief requested; and
 - iv. Evidence that all persons with a financial interest in the procurement have been given notice of the Protest or if such persons are unknown, a statement to that effect.

- B. Who May Protest:
 - i. Protests based on specifications: Any prospective Bidder.
 - ii. Protests following Bid opening: Any Bidder with a substantial financial interest in the award of a Contract.

- C. Time to Protest:
- i. Protests based on specifications or other terms in the Contract Documents must be received by the City no later than ten (10) calendar days prior to the date established for submittal of Bids.
 - ii. The City must receive protests based on other circumstances within five (5) calendar days after the bids are opened and publicly read.
 - iii. In no event shall a Protest be considered if all bids are rejected or after execution of the Contract.
- D. Determination of Protest. Upon receipt of a timely written Protest, the City shall investigate the Protest and shall respond in writing to the Protest prior to the award of Contract. If protest is submitted in accordance with the procedures set forth above, the City will not execute a contract any sooner than two (2) business days after the City's decision on the Protest.
- E. Failure to Comply. Failure to comply with the procedures set forth herein may render a Protest untimely or inadequate and may result in rejection thereof by the City.
- F. Exhaustion of Administrative Remedies. By submitting a bid, the Bidder agrees the Bidder's compliance with the protest procedures set forth herein are a mandatory condition precedent to the Bidder initiating a lawsuit against the City.
- G. Venue. By submitting a bid, the Bidder acknowledges and agrees that a lawsuit or action related to or arising out of this procurement shall be brought in the Superior Court of King County, Washington.

III: BIDDER'S CHECK LIST

ALL BIDDERS must properly complete, execute and submit the following with their bids:

1. **NON-COLLUSION DECLARATION:** Failure to submit the certificate shall make the bid non-responsive and not eligible for award.
2. **BID FORM:** Bidders must bid on all items contained in the Bid Form and the Form must be signed. The omission or deletion of any bid item may render the bid non-responsive and result in the rejection of the bid. Bidders are reminded to comply with RCW 39.30.060.
3. **CONTRACTOR DECLARATION PURSUANT TO RCW 39.04.350(2):** Failure to submit the declaration shall make the bid non-responsive and not eligible for award.
4. **BID GUARANTY BOND:** Failure to furnish a bid deposit of a minimum of five percent (5%) shall make the bid non-responsive and not eligible for award.
5. **BIDDERS QUALIFICATION CERTIFICATE:** To be completed and signed. The City reserves the right to check all statements and to judge the adequacy of the bidder's qualifications.

To assist the City in the review of the responsible Bidder's qualifications, the Bidder(s) shall, within five (5) days of being requested to do so by the City, provide the information required in Evaluation of Bidder Responsibility of the Instructions to Bidders, including a statement in accordance with RCW 9A.72.085 verifying compliance with responsible bidder criteria requirement of RCW 39.04.350(1)(g).

The **SUCCESSFUL BIDDER** shall properly complete, execute (as required) and submit the following after receiving notice of the award of the Project.

1. Public Works Contract,
2. Performance Bond,
3. Payment Bond,
4. Certificate of Insurance,
5. Retainage Agreement,
6. Statement of Intent to Pay Prevailing Wages,
7. Other documents requested by City.

BIDDING REQUIREMENTS

I: NON-COLLUSION CERTIFICATE

STATE
OF Washington)
) ss
COUNTY OF King)

The undersigned, being duly sworn, deposes and says that the person, firm, association, co-partnership or corporation herein named, has not, either directly or indirectly, entered into any agreement, participated in any collusion, or otherwise taken any action in restraint of free competitive bidding in the preparation and submission of a proposal to the City of Mercer Island for consideration in the award of a contract on the improvement described as follows:

2023 RESIDENTIAL STREET OVERLAYS

(Name of Firm)

CORPORATE SEAL:

By: _____
(Authorized Signature)

Title: _____

Sworn to before me this ____ day of _____, _____.

Notary Public

II. BID FORM

(NOTE TO BIDDER: This BID FORM shall be completed in ink or typewritten)

TO: City of Mercer Island

ADDRESS: 9611 SE 36th Street
Mercer Island, Washington 98040

PROJECT TITLE: 2023 Residential Street Overlays

Bidder Declaration and Understanding

The undersigned Bidder hereby declares that they have carefully examined the Contract Documents for the construction of the project, that they have personally inspected the site, that they have satisfied themselves as to the quantities involved, including materials and equipment, and conditions of work involved, including the fact that the description of the quantities of work and materials, as included herein, is brief and is intended only to indicate the general nature of the work and to identify the quantities with the detailed requirements of the Contract Documents, and that this Proposal is made according to the provisions and under the terms of the Contract Documents, which Documents are hereby made a part of this Proposal. The Bidder further declares that they have exercised their own judgment regarding the interpretation of subsurface information and has utilized all data, which they believe pertinent from the Engineer, Owner, and other sources and have made such independent investigations as the Bidder deems necessary in arriving at their conclusions.

The Bidder is hereby notified that no goal for disadvantaged business enterprise utilization has been established for this project. As part of the City's affirmative action effort, however, the City encourages participation of certified disadvantaged businesses and women business enterprises to act as prime contractors as well as subcontractors on this project.

The undersigned Bidder hereby declares that Bidder has carefully examined the Contract Documents including the following addenda, receipt of all is hereby acknowledged:

Addendum Number	_____	Date	_____
	_____		_____
	_____		_____
	_____		_____

Start of Construction and Contract Completion Time

The Bidder agrees that he will begin work within 10 calendar days of the Notice to Proceed, and Final Completion of the entire project will be achieved by the Final Completion Date (except for extensions of time granted in accordance with the General Terms and Conditions). The Bidder further agrees he/she will, if necessary, accelerate his work, provide additional workers and equipment, and expedite materials delivery to meet these dates, all at no additional expense to the OWNER.

With the submission of this bid, the bidder hereby agrees to achieve Final Completion within 40 working days from the Notice to Proceed and the Substantial Completion Date will be as stated in the project timeline below.

The project consists of the following Schedules of Work:

- Schedule A – Madrona Crest West Residential Overlay
- Schedule B – Madrona Crest East Residential Overlay
- Schedule C – Pavement Repairs (Various Locations)

Project timeline and work limitations for this contract are:

1. A contract is scheduled for City Council award June 6, 2023.
2. A preconstruction meeting is tentatively planned for the week of June 26, 2023.
3. Notice to Proceed with construction is anticipated by the week of July 3, 2023.
4. Start of construction is anticipated no earlier than July 3, 2023.
5. Work on Schedule A shall start no sooner than July 3, 2023, and work on Schedule B will start no sooner than August 1, 2023. Work for both schedules shall be substantially complete, including all asphalt paving and all pavement markings, by August 29, 2023.
6. All work on all schedules shall be physically complete by October 1, 2023.
7. School will begin on August 20, 2023. School bus routes and stops are located within the residential neighborhoods.
8. Seafair airshow practice activities on August 3 and 4, 2023, and associated I-90 floating bridge closures may affect access to Mercer Island.
9. June 19, 2023 is a new federal holiday (Juneteenth), and city offices and facilities will be closed.

Coordination with Other Contractors

Ahead of this project's construction, City personnel and an independent contractor will be performing the following:

1. An independent contractor will be constructing storm drainage utility improvements within the paving limits. The residential utility work within the limits of Schedule A is planned to be complete by July 1, 2023.
2. The residential utility work within the limits of Schedule B is planned to be complete by August 1, 2023.
3. City Public Works Department crews will be trimming overhanging vegetation within the limits of this contract in May and June.

Lump Sum or Unit Price Work

The Bidder proposes to accept as full payment for the work proposed herein the amounts computed under the provisions of the Contract Documents and based on the following lump sum or unit price amounts, it being expressly understood that the unit prices are independent of the exact quantities involved. The Contractor shall be compensated for the actual unit quantities performed in accordance with the General Terms and Conditions set forth in these Contract Documents. The Bidder agrees that the lump sum prices and the unit prices represent a true measure of the labor, services, and materials required to perform the work, including all allowances for Contractor-paid taxes, overhead, and profit for each type and unit of work, as well as any auxiliary costs associated

with completing a unit of work called for in these Contract Documents. The City does not guarantee the quantities estimated for unit price items, nor does the City limit itself to the estimated number.

If any material, item, or service required by the Contract Documents has not been mentioned specifically, the same shall be furnished and placed with the understanding that the full cost to the Owner has been merged with the prices named in the Proposal.

To the extent possible, standard bid items have been utilized for the work listed in the Proposal. The Bidder is directed to review the Standard Specifications and the City of Mercer Island's Amendments (Special Provisions herein) for descriptions of bid item work, measurement, and payment.

Certification of Non-Segregated Facilities

The Bidder certifies that the Bidder does not maintain or provide for the Bidder's Employees any segregated facilities at any of the Bidder's establishments, and that the Bidder does not permit the Bidder's employees to perform their services at any location, under the Bidder's control, where segregated facilities are maintained.

Prevailing Wages

The Bidder agrees to pay to labor not less than the hourly minimum rates of wages and fringe benefits determined by the State of Washington Department of Labor and Industries as included in the Appendix.

2023 RESIDENTIAL STREET OVERLAYS
Bid Schedule A – Madrona Crest West Residential Overlay

NO.	DESCRIPTION OF ITEM (SPECIFICATION REFERENCE)	APPROX QUANTITY	UNITS	UNIT PRICE	EXTENDED AMOUNT FOR ITEM
A1	Minor Change (1-04)	1	EST	\$ 2,800.00	\$ 2,800.00
A2	Mobilization (1-09)	1	LS	\$	\$
A3	Traffic Control Labor (1-10)	290	HR	\$	\$
A4	Traffic Control Supervisor (1-10)	1	LS	\$	\$
A5	Crushed Surfacing Top Course (or Base Course) (4-04)	150	TON	\$	\$
A6	Planing Bituminous Pavement (5-04)	1,075	SY	\$	\$
A7	Pavement Repair Excavation Incl Haul (5-04)	710	SY	\$	\$
A8	HMA for Pavement Repair Cl. B (5-04)	100	TON	\$	\$
A9	HMA for Paving Cl. B (5-04)	1,505	TON	\$	\$
A10	Asphalt Cost Price Adjustment (5-04)	1	CALC	\$ 4,800.00	\$ 4,800.00
A11	Lower Utility for Profile Grinding (7-05)	11	EA	\$	\$
A12	Furnish and Install 18"x24" New Catch Basin Frame and Grate (7-05)	5	EA	\$	\$
A13	Install New Manhole Ring and Cover (7-05)	13	EA	\$	\$
A14	Adjust Catch Basin (7-05)	14	EA	\$	\$
A15	Adjust Valve Box (7-12)	31	EA	\$	\$
A16	Adjust Water Meter Box (7-15)	1	EA	\$	\$
A17	Inlet Protection (8-01)	45	EA	\$	\$
A18	Erosion/Water Pollution Control (8-01)	1	FA	\$ 4,200.00	\$ 4,200.00
A19	Property Restoration (8-02)	1	FA	\$ 4,200.00	\$ 4,200.00
A20	Raised Pavement Marker Type 1 (8-09)	40	EA	\$	\$

**2023 RESIDENTIAL STREET OVERLAYS
 Bid Schedule A – Madrona Crest West Residential Overlay**

NO.	DESCRIPTION OF ITEM (SPECIFICATION REFERENCE)	APPROX QUANTITY	UNITS	UNIT PRICE	EXTENDED AMOUNT FOR ITEM
A21	Raised Pavement Marker Type 2 (8-09)	15	EA	\$ _____	\$ _____
A22	Adjust Monument (8-13)	1	EA	\$ _____	\$ _____
A23	Plastic Line, 12 In. White (8-22)	40	LF	\$ _____	\$ _____
A24	Plastic Sharrow Symbol (8-22)	5	EA	\$ _____	\$ _____
A25	Plastic Speed Bump Symbol (8-22)	3	EA	\$ _____	\$ _____

TOTAL BID AMOUNT SCHEDULE A

\$ _____

Dollars

 Total Bid Amount Schedule A in Writing

2023 RESIDENTIAL STREET OVERLAYS
Bid Schedule B – Madrona Crest East Residential Overlay

NO.	DESCRIPTION OF ITEM (SPECIFICATION REFERENCE)	APPROX QUANTITY	UNITS	UNIT PRICE	EXTENDED AMOUNT FOR ITEM
B1	Minor Change (1-04)	1	EST	\$ 5,900.00	\$ 5,900.00
B2	Mobilization (1-09)	1	LS	\$	\$
B3	Traffic Control Labor (1-10)	430	HR	\$	\$
B4	Traffic Control Supervisor (1-10)	1	LS	\$	\$
B5	Remove Asphalt Conc. Pavement (2-02)	100	SY	\$	\$
B6	Remove Cement Conc. Pavement (2-02)	17	SY	\$	\$
B7	Remove Cement Conc. Curb (2-02)	35	LF	\$	\$
B8	Roadway Excavation Incl. Haul (2-03)	40	CY	\$	\$
B9	Crushed Surfacing Top Course (or Base Course) (4-04)	250	TON	\$	\$
B10	Shaping and Compaction (4-04)	1,800	SY	\$	\$
B11	Planing Bituminous Pavement (5-04)	7,000	SY	\$	\$
B12	Pavement Repair Excavation Incl Haul (5-04)	490	SY	\$	\$
B13	HMA for Pavement Repair Cl. B (5-04)	65	TON	\$	\$
B14	HMA for Paving Cl. B (5-04)	3,200	TON	\$	\$
B15	Asphalt Cost Price Adjustment (5-04)	1	CALC	\$ 9,800.00	\$ 9,800.00
B16	Lower Utility for Profile Grinding (7-05)	37	EA	\$	\$
B17	Furnish and Install 18"x24" New Catch Basin Frame and Grate (7-05)	28	EA	\$	\$
B18	Install New Manhole Ring and Cover (7-05)	21	EA	\$	\$
B19	Adjust Catch Basin (7-05)	17	EA	\$	\$
B20	Furnish and Install Rectangular Solid Metal Cover (7-05)	4	EA	\$	\$

2023 RESIDENTIAL STREET OVERLAYS
Bid Schedule B – Madrona Crest East Residential Overlay

NO.	DESCRIPTION OF ITEM (SPECIFICATION REFERENCE)	APPROX QUANTITY	UNITS	UNIT PRICE	EXTENDED AMOUNT FOR ITEM
B21	Adjust Valve Box (7-12)	56	EA	\$ _____	\$ _____
B22	Adjust Water Meter Box (7-15)	3	EA	\$ _____	\$ _____
B23	Inlet Protection (8-01)	63	EA	\$ _____	\$ _____
B24	Erosion/Water Pollution Control (8-01)	1	FA	\$ 8,850.00	\$ 8,850.00
B25	Property Restoration (8-02)	1	FA	\$ 8,850.00	\$ 8,850.00
B26	Raised Pavement Marker Type 2 (8-09)	10	EA	\$ _____	\$ _____
B27	Adjust Monument (8-13)	4	EA	\$ _____	\$ _____
B28	Cement Concrete Sidewalk (8-14)	15	SY	\$ _____	\$ _____
B29	Detectable Warning Surface (8-14)	64	SF	\$ _____	\$ _____
B30	Permanent Signing (8-21)	1	LS	\$ _____	\$ _____
B31	Paint Line, 4 In. White (8-22)	150	LF	\$ _____	\$ _____
B32	Plastic Line, 12 In. White (8-22)	50	LF	\$ _____	\$ _____
B33	Plastic 25 MPH Symbol (8-22)	6	EA	\$ _____	\$ _____
B34	Plastic Traffic Arrow (8-22)	1	EA	\$ _____	\$ _____

TOTAL BID AMOUNT SCHEDULE B

\$ _____

Dollars

 Total Bid Amount Schedule B in Writing

2023 RESIDENTIAL STREET OVERLAYS
Bid Schedule C – Pavement Repairs (Various Locations)

NO.	DESCRIPTION OF ITEM (SPECIFICATION REFERENCE)	APPROX QUANTITY	UNITS	UNIT PRICE	EXTENDED AMOUNT FOR ITEM
C1	Minor Change (1-04)	1	EST	\$ 400.00	\$ 400.00
C2	Mobilization (1-09)	1	LS	\$	\$
C3	Traffic Control Labor (1-10)	20	HR	\$	\$
C4	Traffic Control Supervisor (1-10)	1	LS	\$	\$
C5	Crushed Surfacing Top Course (or Base Course) (4-04)	30	TON	\$	\$
C6	Pavement Repair Excavation Incl Haul (5-04)	605	SY	\$	\$
C7	HMA for Pavement Repair Cl. ½" (5-04)	119	TON	\$	\$
C8	Asphalt Cost Price Adjustment (5-04)	1	CALC	\$ 360.00	\$ 360.00
C9	Install New Manhole Ring and Cover (7-05)	2	EA	\$	\$
C10	Adjust Catch Basin (7-05)	1	EA	\$	\$
C11	Inlet Protection (8-01)	5	EA	\$	\$
C12	Erosion/Water Pollution Control (8-01)	1	FA	\$ 1,150.00	\$ 1,150.00

TOTAL BID AMOUNT SCHEDULE C

\$ _____

Dollars

 Total Bid Amount Schedule C in Writing

BID SUMMARY

Unit prices for all items, all extensions, and the total amount of bid must be shown on all Schedules. Where conflict occurs between the unit price and the total amount named for any item, the unit price shall prevail, and the totals shall be corrected to conform thereto.

The bidder shall bid on all Schedules included in the Bid Form.

The basis for award shall be the combined total of Bid Schedules A and B. The successful bidder will be the bidder submitting the lowest responsible bid for Schedules A and B.

2023 RESIDENTIAL STREET OVERLAYS

Schedule A – Madrona Crest West Residential Overlay

Schedule B – Madrona Crest East Residential Overlay

Schedule C – Pavement Repairs (Various Locations)

Date: _____

Total Bid Amount (Schedule A + Schedule B + Schedule C)

\$ _____
In Words

\$ _____
In Figures

Subcontractor Listing – RCW 39.30.060

Pursuant to RCW 39.30.060, the Bidder shall list as part of its Bid either itself or the names of the subcontractors with whom the Bidder, if awarded the contract, will subcontract for performance of the work of heating, ventilation and air conditioning (“HVAC”), plumbing as described in chapter 18.106 RCW, and electrical as described in chapter 19.28 RCW. The Bidder shall not list more than one subcontractor for each category of work.

Failure of the Bidder to submit as part of the Bid the names of such subcontractors or to name itself to perform such work or the naming of two or more subcontractors to perform the same category of work shall render the Bidder’s Bid nonresponsive and therefore, void.

The requirement of this section to name the Bidder’s proposed HVAC, plumbing, and electrical subcontractors applies only to proposed HVAC, plumbing, and electrical subcontractors who will contract directly with the general contractor submitting the Bid to the City.

Electrical work must be performed by a licensed electrical contractor. Bidders are cautioned that installation of electrical equipment (PVC or metal conduit, junction boxes or similar work) may be considered electrical work even if for future use and no electrical current is involved.

If the subcontract work categories as described above are not applicable to the work being bid, the bidder must indicate that the subcontract category is “NOT APPLICABLE.”

HVAC

Subcontractor Name: _____

UBI Number: _____

Plumbing

Subcontractor Name: _____

UBI Number: _____

Electrical

Subcontractor Name: _____

UBI Number: _____

PROPOSAL SIGNATURE SHEET

If Sole Proprietor, Partnership or Joint Venture

IN WITNESS hereto the undersigned have set their hands this

_____ day of _____, 20 _____.

Name of Bidder (name each partner
or joint venture partner) _____

Washington Contractor's Registration
No. _____

Address _____

Authorized Signature _____

Position/Title _____

If Corporation or Limited Liability Company (LLC)

IN WITNESS WHEREOF the undersigned corporation has caused this instrument to be executed and
its seal affixed by its duly authorized officers this

_____ day of _____, 20 _____.

Name of Corporation or Limited
Liability Company (LLC) _____

Washington Contractor's Registration
No. _____

Address _____

State of Incorporation or Organization _____

Authorized Signature _____

Position/Title _____

III: BID GUARANTY BOND

KNOW ALL BY THESE PRESENTS: That we, _____,
as Principal, and _____, as Surety, are jointly and severally held and firmly bound unto the City of Mercer Island, hereinafter called the Obligee, each in the penal sum of five percent (5%) of the Principal's Total Bid Price for the work, this sum not to exceed _____ DOLLARS (\$_____) (hereinafter referred to as "penal sum") of lawful money of the United States, for the payment whereof unto the Obligee.

WHEREAS, the Principal is herewith submitting its bid proposal for the

2023 Residential Street Overlays

NOW, THEREFORE, the condition of this obligation is such that if the Principal is awarded the Contract, and if the Principal, within the time specified, fulfills all of the requirements of the Contract Documents which are conditions precedent to the execution of the Agreement, enters into, executes and delivers to the Obligee an agreement on the form provided herein complete with evidences of insurance, and if the Principal, within the time specified, gives to the Obligee the performance and payment bond on the forms provided herein, then this obligation shall be void; otherwise, the Principal and Surety shall pay unto the Obligee the penal sum; provided however, in no event shall the Surety's liability exceed the penal sum. Provided further, if the difference in money between the Principal's Total Bid Price and the amount for which the Obligee legally contracts with another party to fulfill the Contract is greater than the penal sum, the Principal shall pay unto the Obligee the difference between the penal sum and the amount the Obligee pays another to fulfill the Contract.

AND IT IS HEREBY DECLARED AND AGREED that the Surety shall be liable under this obligation as Principal, and that nothing of any kind or nature whatsoever that will not discharge the Principal shall operate as a discharge or a release of liability of the Surety.

IT IS HEREBY FURTHER DECLARED AND AGREED that this obligation shall be binding upon and inure to the benefit of the Principal, the Surety and the Obligee and their respective heirs, executors, administrators, successors and assigns.

SIGNED this _____ day of _____, 20 _____.

Principal: _____

Surety: _____

By: _____

By: _____

Title: _____

Title: _____

Address: _____

Address: _____

Telephone: () _____

Telephone: () _____

Note: A power of attorney must be provided which appoints the Surety's true and lawful attorney-in-fact to make, execute, seal and deliver this bid guaranty bond.

IV. BIDDER'S QUALIFICATION CERTIFICATE

The undersigned hereby certifies and submits the following:

Company Name _____

Address _____

Owner Name _____

Contact Person _____

Contact Person's Title _____

Phone _____

E-mail _____

Washington State Contractor Registration # _____

Washington State Unified Business Identifier (UBI) # _____

Federal Tax ID # _____

City of Mercer Island Business License #
(required prior to award of contract) _____

	Yes or No	Account / Registration Number (as applicable)
Does the contractor have industrial insurance coverage for its employees working in Washington as required by Title 51 RCW?	_____	_____
Does the contractor have a Washington State excise tax registration number as required by Title 82 RCW?	_____	_____
Does the contractor have a Washington State Employment Security Department number as required by Title 50 RCW?	_____	_____
Has the contractor been disqualified from bidding on any public works contract under RCW 39.06.010 or 39.12.065(3)?	_____	_____
Has the contractor received training on the requirements related to public works contracts and prevailing wage requirements pursuant to RCW 39.04.350(f) and chapter 39.12 RCW, or is the contractor otherwise exempt from this requirement by the department of labor and industries?	_____	_____

Within the three-year period immediately preceding the date of the bid solicitation, has the contractor been determined by a final and binding citation and notice of assessment issued by the Department of Labor and Industries or through a civil judgment entered by a court of limited or general jurisdiction to have willfully violated, as defined in RCW 49.48.082, any provision of Chapters 49.46, 49.48, or 49.52 RCW?

By:

Signature
Title

Print Name
Date

AGREEMENT FORMS

**CITY OF MERCER ISLAND, WASHINGTON
PUBLIC WORKS CONTRACT
FOR
2023 RESIDENTIAL STREET OVERLAYS**

THIS PUBLIC WORKS CONTRACT ("Contract") dated _____, 2023, is effective on the date the Contract is fully executed by the Parties. The Parties to this Contract are the CITY OF MERCER ISLAND, a Washington municipal corporation ("City" or "Owner"), and _____, a Washington Corporation ("Contractor").

A. The City desires to retain an independent contractor to furnish all labor and materials necessary to perform work at various street locations, Mercer Island, Washington ("Property"); and

B. The Contractor has the requisite skill and experience to perform such work and has submitted a proposal dated _____, 2023 to complete such work ("Proposal").

NOW, THEREFORE, the parties ("Parties") agree to the following terms and conditions:

1. SERVICES BY CONTRACTOR

- 1.1 Description of Work. Contractor shall perform all work and furnish all tools, materials, supplies, equipment, labor and other items incidental thereto necessary for the construction and completion of the work, more particularly described in the Contract Documents for the 2023 ARTERIAL AND RESIDENTIAL STREET OVERLAYS Project, including this Public Works Contract, the Contractor's completed Bid Form, the City's General Terms and Conditions (May 2020 ed.), any Supplemental and/or Special Conditions, Technical Specifications, Drawings and Addenda, which documents are incorporated by this reference, ("Work"), which Work shall be completed to the City's satisfaction, within the time period prescribed by the City and pursuant to the direction of the City Manager or his or her designee.
- 1.2 Completion Date. The Work shall be commenced within ten (10) days of receipt by the Contractor of the City's Notice to Proceed and shall be Substantially Completed by August 30, 2023, (the "Contract Time") as may be extended in accordance with the Contract Documents. In the event the Work is not completed within the time specified, Contractor agrees to pay to the City liquidated damages in the amount set forth in Section 1.3 of this Contract.
- 1.3 Liquidated Damages. TIME IS OF THE ESSENCE OF THIS CONTRACT. Delays inconvenience the residents of Mercer Island and cost taxpayers undue sums of money, adding time needed for administration, engineering, inspection and supervision. It is impractical for the City to calculate the actual cost of delays. Accordingly, the Contractor agrees to pay liquidated damages as follows: Liquidated damages for failure to achieve timely Substantial Completion shall be in the amount of \$250.00 per day.
- 1.4 Performance Standard. Contractor shall perform the Work in a manner consistent with accepted practices for highly skilled and competent contractors performing this type of work in this area.
- 1.5 Compliance with Laws. Contractor shall perform the Work in accordance with all applicable federal, state and City laws, including but not limited to all City ordinances, resolutions, standards, or policies, as now existing, or hereafter adopted or amended, and obtain all necessary permits and pay all permit, inspection, or other fees, at its sole cost and expense.
- 1.6 Utility Location. Contractor is responsible for locating any underground utilities affected by the Work and is deemed to be an excavator for purposes of Chapter 19.122 RCW, as amended. Contractor shall be responsible

for compliance with Chapter 19.122 RCW, including utilization of the "one call" locator system before commencing any excavation activities.

- 1.7 Air Environment. Contractor shall fully cover any and all loads of loose construction materials including without limitation, sand, dirt, gravel, asphalt, excavated materials, construction debris, etc., to protect said materials from air exposure and to minimize emission of airborne particles to the ambient air environment within the City of Mercer Island.

2. TERM

This Contract shall commence on the effective date of this Contract and continue until the Work is complete, and formally accepted by City, and all warranties have expired.

3. REQUISITE SKILL

The Contractor warrants that it has the requisite skill to complete the Work and is appropriately accredited and licensed by all applicable agencies and governmental entities, including but not limited to being registered to do business in the City of Mercer Island by obtaining a City of Mercer Island business registration. Contractor represents that it has visited the site and is familiar with all of the plans and specifications in connection with the completion of the Work.

4. COMPENSATION

- 4.1 Total Compensation. In consideration of the Contractor performing the Services, the City agrees to pay the Contractor an amount not to exceed Dollars (\$), based on the Proposal submitted by Contractor dated and as may be adjusted under the Contract Documents.

- 4.2 Contractor Responsible for Taxes. Except as otherwise stated in the Contract Documents, the Contractor shall be solely responsible for the payment of any taxes imposed by any lawful jurisdiction as a result of the performance and payment of this Contract.

- 4.3 Method of Payment. Payment by the City for the Work will only be made after the Work has been completed, a voucher or invoice is submitted in a form satisfactory to the City, and such invoice is approved by the appropriate City representative. Payment shall be made within thirty (30) days of receipt of such invoice or voucher unless otherwise set forth in the Bid Form. The Contractor's acceptance of such payment for the Work shall constitute full compensation for the performance of the Work. Invoices shall be submitted to:

City of Mercer Island
ATTN: Ian Powell, Street Engineer
9611 SE 36th Street
Mercer Island, WA 98040

- 4.4 Retainage. Pursuant to Chapter 60.28 RCW, five percent (5%) of the Total Compensation shall be retained by the City to assure payment of Contractor's state taxes as well as payment of subcontractors, suppliers, and laborers. Upon execution of this Contract, Contractor shall complete, execute, and deliver to the City the Contractor's Retainage Agreement set forth in the Contract Documents. No payments shall be made by the City from the retained percentage fund ("Fund") nor shall the City release any retained percentage escrow account to any person, until the City has received from the Department of Revenue a certificate that all taxes, increases, and penalties due from the Contractor and all taxes due and to become due with respect to the Contract have been paid in full or that they are, in the Department's opinion, readily collectible without recourse to the State's lien on the retained percentage. Upon non-payment by the general contractor, any supplier or subcontractor may file a lien against the retainage funds, pursuant to Chapter 60.28 RCW. Subcontractors or suppliers are required

to give notice of any lien within thirty (30) days of the completion of the Work and in the manner provided in RCW 39.08.030. Within sixty (60) days after completion of all Work on this Contract, the City shall release and pay in full the money held in the Fund, unless the City becomes aware of outstanding claims made against this Fund.

5. EQUAL OPPORTUNITY EMPLOYER

In all Contractor services, programs or activities, and all Contractor hiring and employment made possible by or resulting from this Contract, there shall be no discrimination by Contractor or by Contractor's employees, agents, subcontractors or representatives against any person because of sex, sexual orientation, age (except minimum age and retirement provisions), race, color, creed, national origin, marital status or the presence of any disability, including sensory, mental or physical handicaps, unless based upon a bona fide occupational qualification in relationship to hiring and employment. This requirement shall apply, but not be limited to the following: employment, advertising, layoff or termination, rates of pay or other forms of compensation, and selection for training, including apprenticeship. Contractor shall not violate any of the terms of Chapter 49.60 RCW, Title VII of the Civil Rights Act of 1964, the Americans With Disabilities Act, Section 504 of the Rehabilitation Act of 1973 or any other applicable federal, state, or local law or regulation regarding non-discrimination. Any material violation of this provision shall be grounds for termination of this Contract by the City and, in the case of the Contractor's breach, may result in ineligibility for further City agreements.

6. INDEPENDENT CONTRACTOR/CONFLICT OF INTEREST

It is the intention and understanding of the Parties that the Contractor shall be an independent contractor and that the City shall be neither liable nor obligated to pay Contractor sick leave, vacation pay or any other benefit of employment, nor to pay any social security or other tax which may arise as an incident of employment. The Contractor shall pay all income and other taxes as due. Industrial or any other insurance which is purchased for the benefit of the City, regardless of whether such may provide a secondary or incidental benefit to the Contractor, shall not be deemed to convert this Contract to an employment contract. It is recognized that Contractor may perform work during the Term of this Contract for other third parties; provided, however, that such performance of other work shall not conflict with or interfere with the Contractor's ability to perform the Work. Contractor agrees to resolve any such conflicts of interest in favor of the City.

7. INDEMNIFICATION

7.1 Indemnification and Hold Harmless.

- A. The Contractor shall protect, defend, indemnify, and hold harmless City, its elected officials, officers, agents, volunteers, and employees, from any and all claims, demands, suits, penalties, losses, damages, judgments, or costs of any kind whatsoever, including attorneys' fees (hereinafter "claims"), arising out of or in connection with the performance of this Contract except for injuries and damages caused by the sole negligence of the City. However, should a court of competent jurisdiction determine that this Contract is subject to RCW 4.24.115, then, in the event of liability for damages arising out of bodily injury to persons or damages to property caused by or resulting from the concurrent negligence of the Contractor and the City, its officers, officials, employees, and volunteers, the Contractor's liability hereunder shall be only to the extent of the Contractor's negligence.
- B. The Contractor's obligations under this section shall include, but not be limited to,
 - i. The duty to promptly accept tender of defense and provide defense to City at the Contractor's own expense.

- ii. The duty to indemnify and defend City, its elected officials, officers, agents, and employees, from any claim, demand, and/or cause of action brought by or on behalf of any of its employees, or agents. The foregoing duty is specifically and expressly intended to constitute a waiver of the Contractor's immunity under Washington's Industrial Insurance Act, RCW Title 51, as respects City with a full and complete indemnity and defense of claims made by the Contractor's employees. The parties acknowledge that these provisions were mutually negotiated upon by them.
- iii. To the maximum extent permitted by law, the Contractor shall indemnify and defend City, its elected officials, officers, agents and employees, from and be liable for all damages and injury which shall be caused to owners of property on or in the vicinity of the work or which shall occur to any person or persons or property whatsoever arising out of the performance of this Contract, whether or not such injury or damage is caused by negligence of the Contractor or caused by the inherent nature of the work specified.

- C. City may, in its sole discretion, (1) withhold amounts sufficient to pay the amount of any claim for injury, and/or (2) pay any claim for injury of which City may have knowledge, regardless of the formalities of notice of such claim, arising out of the performance of this Contract.
- D. Any amount withheld will be held until the Contractor secures a written release from the claimant, obtains a court decision that such claim is without merit, or satisfies any judgment on such claim. In addition, the Contractor shall reimburse and otherwise be liable for claims costs incurred by City, including, without limitation, costs for claims adjusting services, attorneys, engineering, and administration.
- E. In the event City incurs any judgment, award, and/or costs arising therefrom, including attorneys' fees, to enforce the provisions of this article, all such fees, expenses, and costs shall be recoverable from the Contractor.
- F. This provision has been mutually negotiated by the City and the Contractor.

7.2 Survival. The provisions of this Section 7 shall survive the expiration or termination of this Contract with respect to any event occurring prior to such expiration or termination.

8. INSURANCE

8.1 The Contractor agrees to carry without interruption from commencement of the Contractor's work through the term of the contract and for thirty (30) days after Physical Completion, unless otherwise indicated herein, the following insurance against claims for injuries to persons or damage to property which may arise from or in connection with the performance of the Work by Contractor, its agents, representatives, employees or subcontractors with a carriers having a current A.M. Best rating of not less than A:VII. The City, at its discretion, may require additional types and greater limits of insurance coverage commensurate with the risk associated with the performance of the Work.

- A. Workers' Compensation and Employer's Liability Insurance in amounts sufficient pursuant to the laws of the State of Washington.
- B. Commercial general liability insurance shall be written on a form at least as broad as Insurance Services Office (ISO) occurrence form CG 00 01 and shall cover liability arising from premises, operations, independent contractors, products-completed operations for three years following substantial completion of the Work, stop gap liability, personal injury and advertising injury, and liability assumed

under an insured contract. The Commercial General Liability insurance shall be endorsed to provide the Aggregate Per Project Endorsement ISO form CG 25 03 05 09. There shall be no exclusion for liability arising from explosion, collapse, or underground property damage. The City shall be named as an additional insured under the Commercial General Liability insurance policy with respect to the Work performed for the City using ISO Additional Insured endorsement CG 20 10 10 01 and Additional Insured Completed Operations endorsement CG 20 37 10 01 or substitute endorsements providing coverage at least as broad, with limits of no less than \$2,000,000 each occurrence, \$2,000,000 general aggregate, and a \$2,000,000 products-completed operations aggregate limit.

- C. Automobile liability insurance covering all owned, non-owned, hired, and leased vehicles. Coverage shall be written on ISO form CA 00 01 or a substitute form providing equivalent liability coverage. If necessary, the policy shall be endorsed to provide contractual liability coverage with combined single limits for bodily injury and property damage of not less than \$1,000,000 per accident.
- D. Asbestos Abatement or Hazardous Materials. If asbestos abatement or hazardous materials work is performed, Contractor shall review coverage with the City Attorney's office and provide scope and limits of coverage that are appropriate for the scope of Work and are satisfactory to the City. Contractor shall not commence any Work until its coverage has been approved by the City Attorney's office.
- E. Builders Risk insurance covering interests of the City, the Contractor, Subcontractors, and Sub-subcontractors in the work. Builders Risk insurance shall be on a special perils policy form and shall insure against the perils of fire and extended coverage and physical loss or damage including flood, earthquake, theft, vandalism, malicious mischief, and collapse. The Builders Risk insurance shall include coverage for temporary buildings, debris removal, and damage to materials in transit or stored off-site. This Builders Risk insurance covering the work will have a deductible of \$5,000 for each occurrence, which will be the responsibility of the Contractor. Higher deductibles for flood and earthquake perils may be accepted by the City upon written request by the Contractor and written acceptance by the City. Any increased deductibles accepted by the City will remain the responsibility of the Contractor. The Builders Risk insurance shall be maintained until the City has granted substantial completion of the project. An installation floater may be acceptable in lieu of Builders Risk for renovation projects only if approved in writing by the City. Builders Risk insurance shall be written in the amount of the completed value of the project with no coinsurance provisions.

8.2 The City shall be named as additional insured on all such insurance policies, with the exception of workers' compensation coverages. The Contractor's insurance coverage shall be primary insurance as respect the City. Any insurance, self-insurance, or insurance pool coverage maintained by the City shall be excess of the Contractor's insurance and shall not contribute with it. If the Contractor maintains higher insurance limits than the minimums shown above, the City shall be insured for the full available limits of Commercial General and Excess or Umbrella liability maintained by the Contractor, irrespectively of whether such limits maintained by the Contractor are greater than those required by this Contract or whether any certificate of insurance furnished to the City evidences limits of liability lower than those maintained by the Contractor. Contractor shall provide certificates of insurance and amendatory endorsements, concurrent with the execution of this Contract, evidencing such coverage and, at City's request, furnish the City with copies of all insurance policies and with evidence of payment of premiums or fees of such policies. The Contractor shall provide the City and all Additional Insureds for this work with written notice of any policy cancellation within two business days of their receipt of such notice.

8.3 The Contractor shall cause each and every Subcontractor to provide insurance coverage that complies with all applicable requirements of the Contractor-provided insurance as set forth herein, except that the Contractor shall have sole responsibility for determining the limits of coverage required to be obtained by Subcontractors. The Contractor shall ensure that the City is an additional insured on each and every Subcontractor's Commercial

General Liability insurance policy using an endorsement at least as broad as ISO CG 20 10 10 01 for ongoing operations and CG 20 37 10 01 for completed operations.

- 8.4. Failure on the part of the Contractor to maintain the insurance as required shall constitute a material breach of contract, upon which the City may, after giving five business days notice to the Contractor to correct the breach, immediately terminate the Contract or, at its discretion, procure or renew such insurance and pay any and all premiums in connection therewith, with any sums so expended to be repaid to the City on demand, or at the sole discretion of the City, offset against funds due the Contractor from the City.
- 8.5. Waiver of Subrogation. The Contractor and the City waive all rights against each other, any of their Subcontractors, Sub-subcontractors, agents, and employees, each of the other, for damages caused by fire or other perils to the extent covered by Builders Risk insurance or other property insurance obtained pursuant to the Insurance Requirements Section of this Contract or other property insurance applicable to the work. The policies shall provide such waivers by endorsement or otherwise.
- 8.6. The Contractor's maintenance of insurance, its scope of coverage and limits as required herein shall not be construed to limit the liability of the Contractor to the coverage provided by such insurance, or otherwise limit the City's recourse to any remedy available at law or in equity.
- 8.7. The provisions of this Section shall survive the expiration or termination of this Contract with respect to any event occurring prior to such expiration or termination.

9. PERFORMANCE/PAYMENT BOND OR ADDITIONAL RETAINAGE

Pursuant to RCW 39.08.010, Contractor shall provide Performance Bond and Payment Bond each in an amount equal to 100% of the amount of this Contract to cover the performance of all provisions of this Contract and the payment of all laborers and suppliers. The Contract bonds shall be in a form set forth in the Contract Documents. The Contract bond shall assure that the Contractor will faithfully perform all of the provisions of the Contract as well as pay all laborers, mechanic subcontractors, materialmen, and suppliers. Contractor's obligations under this Contract shall not be limited to the bond amount.

Alternatively, pursuant to RCW 39.08.010, on contracts of Fifty-Five Thousand Dollars (\$55,000) or less, at the option of the Contractor, the City may, in lieu of a bond, retain ten percent (10%) of the Contract amount for a period of thirty (30) days after the date of final acceptance, or until receipt of all necessary releases from the Department of Revenue and the Department of Labor and Industries and settlement of any liens filed under Chapter 60.28 RCW, whichever is later.

10. SAFETY

Contractor shall take all necessary precautions for the safety of its employees on the work site and shall comply with all applicable provisions of federal, state, and municipal safety and health laws and codes, including without limitation, all OSHA/WISHA requirements, Safety and Health Standards for Construction Work (Chapter 296-155 WAC), General Safety and Health Standards (Chapter 296-24 WAC), and General Occupational Health Standards (Chapter 296-62 WAC). Contractor shall erect and properly maintain, at all times, all necessary guards, barricades, signals, and other safeguards at all unsafe places at or near the Work for the protection of its employees and the public, safe passageways at all road crossings, crosswalks, street intersections, post danger signs warning against known or unusual hazards and do all other things necessary to prevent accident or loss of any kind. Contractor shall protect from damage all water, sewer, gas, steam or other pipes or conduits, and all hydrants and all other property that is likely to become displaced or damaged by the execution of the Work. The Contractor shall, at its own expense, secure and maintain a safe storage place for its materials and equipment and is solely responsible for the same.

11. PREVAILING WAGES

11.1 Wages of Employees. This Contract is subject to the minimum wage requirements of Chapter 39.12 of the Revised Code of Washington, as now existing or hereafter amended or supplemented. In the payment of hourly wages and fringe benefits to be paid to any of Contractor's laborers, workpersons and/or mechanics, Contractor shall not pay less than the "prevailing rate of wage" for an hour's work in the same trade or occupation in the locality within the State of Washington where such labor is performed, as determined by the Industrial Statistician of the Department of Labor and Industries of the State of Washington. Prevailing wages paid pursuant to this Agreement shall be the prevailing wage rates which are in effect on the date when the bids, proposals, or quotes were required to be submitted to the City.

The State of Washington prevailing wage rates applicable for this public works project, which is located in King County, may be found at the following website address of the Department of Labor and Industries: <https://lni.wa.gov/licensing-permits/public-works-projects/prevailing-wage-rates/>. A copy of the applicable prevailing wage rates is also available for viewing at the office of the City located at 9611 SE 36th St, Mercer Island, WA 98040. Upon request, the City will mail a hard copy of the applicable prevailing wages for this project.

11.2 Reporting Requirements. Contractor shall comply with all reporting requirements of the Department of Labor and Industries of the State of Washington. Upon the execution of this Contract, Contractor shall complete and file a Statement of Intent to Pay Prevailing Wages with the Department of Labor and Industries. If requested by the City, the Contractor shall provide certified payroll records for its employees and the employees of its subcontractors. Upon completion of the Work, Contractor shall complete and file an Affidavit of Wages Paid with the Department of Labor and Industries. Contractor shall deliver copies of both the Statement of Intent to Pay Prevailing Wages and the Affidavit of Wages Paid, certified by the Department of Labor and Industries, to the City.

12. SUBCONTRACTOR RESPONSIBILITY

Contractor shall verify responsibility criteria for each first-tier subcontractor, and a subcontractor of any tier that hires other subcontractors must verify responsibility criteria for each of its subcontractors. Verification shall include that each subcontractor, at the time of subcontract execution, meets the responsibility criteria listed in the Instructions to Bidders and possesses an electrical contractor license, if required by chapter 19.28 RCW, or an elevator contractor license, if required by chapter 70.87 RCW. This verification requirement must be included in every public works subcontract or every tier.

13. OWNERSHIP OF DOCUMENTS

All originals and copies of work product, including plans, sketches, layouts, designs, design specifications, records, files computer disks, magnetic media, all finished or unfinished documents or material which may be produced or modified by Contractor while performing the Work shall become the property of the City and shall be delivered to the City at its request.

14. CONFIDENTIALITY

If it is necessary to provide proprietary information, the Contractor shall clearly mark the information on each page of the document(s) as "Proprietary and Confidential". The City is subject to laws regarding the disclosure of public records and document. Proposals and other materials, submitted by the Contractor become public record and may be subject to public disclosure, in whole or in part, and may be released by the City in the event of a request for disclosure. In the event the City receives a public record request for information and the Contractor has marked the requested document as "Proprietary and Confidential", the City shall notify the Contractor of such request and withhold disclosure of such information for not less than five (5) business days, to permit the Contractor to seek judicial protection of such

information; provided that the Contractor shall be solely responsible for all attorney fees and costs in such action and shall save and hold harmless the City from any costs, attorneys fees or penalty assessments under Chapter 42.56 RCW for withholding or delaying public disclosure of such information.

15. BOOKS AND RECORDS

The Contractor agrees to maintain books, records, and documents which sufficiently and properly reflect all direct and indirect costs related to the performance of this Contract and such accounting procedures and practices as may be deemed necessary by the City to assure proper accounting of all funds paid pursuant to this Contract. These records shall be subject at all reasonable times to inspection, review or audit by the City, its authorized representative, the State Auditor, or other governmental officials authorized by law to monitor this Contract.

16. CLEAN UP

At any time ordered by the City and immediately after completion of the Work, the Contractor shall, at its own expense, clean up and remove all refuse and unused materials of any kind resulting from the Work. In the event the Contractor fails to perform the necessary clean up, the City may, but in no event is it obligated to, perform the necessary clean up and the costs thereof shall be immediately paid by the Contractor to the City and/or the City may deduct its costs from any remaining payments due to the Contractor.

17. GENERAL PROVISIONS

This Contract, the Contract Documents and any supporting contract documents contain all of the agreements of the Parties with respect to any matter covered or mentioned in this Contract and no prior agreements or understandings shall be effective for any purpose. No provision of this Contract may be amended except by written agreement of the Parties. Any provision of this Contract which is declared invalid, void or illegal shall in no way affect, impair, or invalidate any other provision hereof and such other provisions shall remain in full force and effect. The Contractor shall not transfer or assign, in whole or in part, any or all of its obligations and rights hereunder without the prior written consent of the City. In the event the City consents to any such assignment or transfer, such consent shall in no way release the Contractor from any of its obligations or liabilities under this Contract. Subject to the preceding sentence, this Contract shall be binding upon and inure to the benefit of the Parties' successors in interest, heirs, and assigns. In the event the City or the Contractor defaults on the performance of any terms in this Contract, and the Contractor or City places the enforcement of the Contract or any part thereof, or the collection of any monies due, in the hands of an attorney, or files suit, each Party shall pay all its own attorneys' fees and expenses. The venue for any dispute related to this Contract shall be King County, Washington. Failure of the City to declare any breach or default immediately upon occurrence thereof, or delay in taking any action in connection with, shall not waive such breach or default. This Contract shall be governed by and interpreted in accordance with the laws of the State of Washington. Each individual executing this Contract on behalf of the City and Contractor represents and warrants that such individuals are duly authorized to execute this Contract. Time is of the essence of this Contract and each and all of its provisions in which performance is a factor. Adherence to completion dates is essential to the Contractor's performance of this Contract.

IN WITNESS WHEREOF, the Parties have executed this Contract the day of , 2023.

CONTRACTOR:

CITY:

CITY OF MERCER ISLAND

By: _____
[insert full legal name and title of signator]

By: _____
Jessi Bon, City Manager

Address:

Attest:

Phone:

By: _____
Andrea Larson, City Clerk

Email:

Approved as to form:

By: _____
Bio Park, City Attorney



CITY OF MERCER ISLAND CONTRACT CHANGE ORDER AGREEMENT

PROJECT TITLE	2023 RESIDENTIAL STREET OVERLAYS
DATE	
CHANGE ORDER NUMBER	
PROJECT NUMBER	
CONTRACTOR NAME	
CONTRACTOR ADDRESS	

CONTRACT CHANGE SUMMARY (all prices include tax)	
Original contract amount	\$
Previous change orders total	\$
This change order	\$
New contract amount	\$

SUMMARY OF PROPOSED CHANGES:

TIMING: The time provided for completion in the contract is UNCHANGED INCREASED DECREASED by ____ calendar days.

INSURANCE: Will this change affect expiration or extent of insurance coverage? YES NO
If 'yes', will the policies be extended? YES NO

COST: The total cost for the changes specified in this change order will INCREASE DECREASE NOT CHANGE the total contract cost by \$ _____ (must match net total from page 2). Cost changes are broken down on page 2 of this document.

STATEMENT: Payment for the above work will be in accordance with the applicable portions of the standard specifications, and with the understanding that all materials, workmanship, and measurements shall be in accordance with the provisions of the standard specifications, the contract plans, and the special provisions governing the types of construction. This document shall become an amendment to the contract and all provisions of the contract not amended herein will apply to this change order.

CONTRACTOR

CITY OF MERCER ISLAND

SIGNATURE DATE

CITY MANAGER SIGNATURE DATE

PRINTED NAME TITLE

CHANGE ORDER COST BREAKDOWN

UNIT COST ITEMS

BID ITEM NUMBER	DESCRIPTION	QUANTITY	UNIT	UNIT PRICE	ITEM TOTAL	ADD or DELETE
SALES TAX (10%) if applicable						
NET TOTAL FOR UNIT COST ITEMS						

LUMP SUM ITEMS

ITEM	DESCRIPTION	COST	ADD or DELETE
SALES TAX (10%) if applicable			
NET TOTAL FOR LUMP SUM ITEMS			

NET TOTAL FOR ALL UNIT COST & LUMP SUM ITEMS (includes applicable tax)	\$
--	----

PERFORMANCE BOND

To City of Mercer Island, WA

Bond No. _____

The City of Mercer Island, Washington has awarded to _____ (Principal), a contract for the construction of the project designated as 2023 Residential Street Overlays, Project No. 23-16, in Mercer Island, Washington (Contract), and said Principal is required to furnish a bond for performance of all obligations under the Contract.

The Principal, and _____ (Surety), a corporation, organized under the laws of the State of _____ and licensed to do business in the State of Washington as surety and named in the current list of "Surety Companies Acceptable in Federal Bonds" as published in the Federal Register by the Audit Staff Bureau of Accounts, U.S. Treasury Dept., are jointly and severally held and firmly bound to the City, in the sum of _____ US Dollars (\$ _____) Total Contract Amount, subject to the provisions herein.

This statutory performance bond shall become null and void, if and when the Principal, its heirs, executors, administrators, successors, or assigns shall well and faithfully perform all of the Principal's obligations under the Contract and fulfill all terms and conditions of all duly authorized modifications, additions, and changes to said Contract that may hereafter be made, at the time and in the manner therein specified; and if such performance obligations have not been fulfilled, this bond shall remain in force and effect.

The Surety for value received agrees that no change, extension of time, alteration or addition to the terms of the Contract, the specifications accompanying the Contract, or to the work to be performed under the Contract shall in any way affect its obligation on this bond, and waives notice of any change, extension of time, alteration or addition to the terms of the Contract or the work performed. The Surety agrees that modifications and changes to the terms and conditions of the Contract that increase the total amount to be paid the Principal shall automatically increase the obligation of the Surety on this bond and notice to Surety is not required for such increased obligation.

This bond may be executed in two (2) original counterparts, and shall be signed by the parties' duly authorized officers. This bond will only be accepted if it is accompanied by a fully executed and original power of attorney for the office executing on behalf of the surety.

PRINCIPAL

SURETY

Principal Signature Date

Surety Signature Date

Printed Name Date

Printed Name Date

Title

Title

Name, address, and telephone of local office/agent of Surety Company is:

**PAYMENT BOND
to City of Mercer Island, WA**

Bond No. _____

The City of Mercer Island, Washington has awarded to _____ (Principal), a contract for the construction of the project designated as **2023 Residential Street Overlays**, Project No. **23-16**, in Mercer Island, Washington (Contract), and said Principal is required under the terms of that Contract to furnish a payment bond in accord with Title 39.08 Revised Code of Washington (RCW) and (where applicable) 60.28 RCW.

The Principal, and _____ (Surety), a corporation organized under the laws of the State of _____ and licensed to do business in the State of Washington as surety and named in the current list of "Surety Companies Acceptable in Federal Bonds" as published in the Federal Register by the Audit Staff Bureau of Accounts, U.S. Treasury Dept., are jointly and severally held and firmly bound to the City, in the sum of _____ US Dollars (\$ _____) Total Contract Amount, subject to the provisions herein.

This statutory payment bond shall become null and void, if and when the Principal, its heirs, executors, administrators, successors, or assigns shall pay all persons in accordance with RCW 39.08, 39.12, and 60.28 including all workers, laborers, mechanics, subcontractors, and materialmen, and all person who shall supply such contractor or subcontractor with provisions and supplies for the carrying on of such work, and all taxes incurred on said Contract under Titles 50 and 51 RCW and all taxes imposed on the Principal under Title 82 RCW; and if such payment obligations have not been fulfilled, this bond shall remain in full force and effect.

The Surety for value received agrees that no change, extension of time, alteration or addition to the terms of the Contract, the specifications accompanying the Contract, or to the work to be performed under the Contract shall in any way affect its obligation on this bond, and waives notice of any changes, extension of time, alteration or addition to the terms of the Contract or the work performed. The Surety agrees that modifications and changes to the terms and conditions of the Contract that increase the total amount to be paid the Principal shall automatically increase the obligation of the Surety on this bond and notice to Surety is not required for such increased obligation.

This bond may be executed in two (2) original counterparts, and shall be signed by the parties' duly authorized officers. This bond will only be accepted if it is accompanied by a fully executed and original power of attorney for the office executing on behalf of the surety.

PRINCIPAL

SURETY

Principal Signature Date

Surety Signature Date

Printed Name Date

Printed Name Date

Title

Title

Name, address, and telephone of local office/agent of Surety Company is:

RETAINAGE AGREEMENT

Contract Title 2023 Residential Street Overlays

Contract Date _____

Contractor Name _____

Contractor Address _____

Contractor Phone _____

Contractor Federal ID # _____

State Law on How Contract Retainage Monies can be Reserved:

RCW 60.28.010 Retained percentage, labor and material Contracts for public improvements or work other than for professional services, provides that there shall be reserved by the city from the monies earned by the contractor on estimates during the progress of the improvement or work, a sum of five percent of such estimates, said sum to be retained by the city as a trust fund for the protection and payment of any persons performing work or supplying provisions or supplies during the work. The monies reserved for contract retainage may be reserved by the contractor choosing one of the following four options:

All investments selected below are subject to City approval.

Contractor Options (Contractor shall place an "x" in one of the boxes below.)

- (a) Retained in a non-interest bearing fund by the public body until released in accordance with applicable state statutes;
- (b) Deposited by the public body in an interest bearing account in a bank, mutual savings bank, or savings and loan association, not subject to withdrawal until released in accordance with applicable state statutes, provided that interest on such account shall be paid to the contractor;
- (c) Placed in escrow with a bank or trust company by the public body until released in accordance with applicable state statutes. The cost of the investment program and the risk thereof is to be borne entirely by the contractor.
- (d) Contractor may submit a Retainage Bond equal to 5% of the total awarded bid amount for all schedules to be held by the public body until released in accordance with applicable state statutes.

Contractor's Bank

If Contractor selects options (b) or (c) above, Contractor shall designate below the bank in which the retainage is to be deposited:

ACCOUNT NO. _____

BANK NAME _____

BANK ADDRESS _____

BANK PHONE # _____

Agreement

Contractor and City agree that all or part of the monies in the account can only be approved for disbursement by Bank to Contractor upon written authorization of the City Finance Director, or his/her authorized designee.

By _____
City of Mercer Island

By _____
Contractor

Date _____

Date _____

FORM19
S:\CITYATTY\FORMS\RFB Retainage Agrmt.doc (rev. 6/21/10)

SPECIAL PROVISIONS

INTRODUCTION TO THE SPECIAL PROVISIONS

(August 14, 2013 APWA GSP)

The Work on this project shall be accomplished in accordance with the *Standard Specifications for Road, Bridge and Municipal Construction*, 2023 edition, as issued by the Washington State Department of Transportation (WSDOT) and the American Public Works Association (APWA), Washington State Chapter (hereafter "Standard Specifications"). The Standard Specifications, as modified or supplemented by the Amendments to the Standard Specifications and these Special Provisions, all of which are made a part of the Contract Documents, shall govern all of the Work.

These Special Provisions are made up of both General Special Provisions (GSPs) from various sources, which may have project-specific fill-ins; and project-specific Special Provisions. Each Provision either supplements, modifies, or replaces the comparable Standard Specification, or is a new Provision. The deletion, amendment, alteration, or addition to any subsection or portion of the Standard Specifications is meant to pertain only to that particular portion of the section, and in no way should it be interpreted that the balance of the section does not apply.

The project-specific Special Provisions are not labeled as such. The GSPs are labeled under the headers of each GSP, with the effective date of the GSP and its source. For example:

(March 8, 2013 APWA GSP)

(April 1, 2013 WSDOT GSP)

(Special Provision)

The Special Provisions noted herein are City of Mercer Island special provisions and are in addition to, or as a replacement for, the Standard Specifications. Where sections are marked "Revised Section," the specifications herein are intended to be a revision or partial revision to the Specifications section noted. Where sections are marked as "New Section," the specifications herein will be an addition to the Standard Specifications section noted. Where sections are marked "Supplement," the specifications herein are to be a supplement to the Standard Specifications section noted. Sections of the Standard Specifications that are not modified or replaced as addressed in these Special Provisions shall remain as described in the Standard Specifications.

Also incorporated into the Contract Documents by reference are:

- *Manual on Uniform Traffic Control Devices for Streets and Highways*, currently adopted edition, with Washington State modifications, if any
- *Standard Plans for Road, Bridge and Municipal Construction*, WSDOT/APWA, current edition

Contractor shall obtain copies of these publications, at Contractor's own expense.

**DIVISION 1
GENERAL REQUIREMENTS**

1-01 DEFINITIONS AND TERMS

1-01.3 Definitions

(January 19, 2022 APWA GSP)

Delete the heading **Completion Dates** and the three paragraphs that follow it, and replace them with the following:

Dates

Bid Opening Date

The date on which the Contracting Agency publicly opens and reads the Bids.

Award Date

The date of the formal decision of the Contracting Agency to accept the lowest responsible and responsive Bidder for the Work.

Contract Execution Date

The date the Contracting Agency officially binds the Agency to the Contract.

Notice to Proceed Date

The date stated in the Notice to Proceed on which the Contract time begins.

Substantial Completion Date

The day the Engineer determines the Contracting Agency has full and unrestricted use and benefit of the facilities, both from the operational and safety standpoint, any remaining traffic disruptions will be rare and brief, and only minor incidental work, replacement of temporary substitute facilities, plant establishment periods, or correction or repair remains for the Physical Completion of the total Contract.

Physical Completion Date

The day all of the Work is physically completed on the project. All documentation required by the Contract and required by law does not necessarily need to be furnished by the Contractor by this date.

Completion Date

The day all the Work specified in the Contract is completed and all the obligations of the Contractor under the contract are fulfilled by the Contractor. All documentation required by the Contract and required by law must be furnished by the Contractor before establishment of this date.

Final Acceptance Date

The date on which the Contracting Agency accepts the Work as complete.

Supplement this Section with the following:

All references in the Standard Specifications or WSDOT General Special Provisions, to the terms "Department of Transportation", "Washington State Transportation Commission",

“Commission”, “Secretary of Transportation”, “Secretary”, “Headquarters”, and “State Treasurer” shall be revised to read “Contracting Agency”.

All references to the terms “State” or “state” shall be revised to read “Contracting Agency” unless the reference is to an administrative agency of the State of Washington, a State statute or regulation, or the context reasonably indicates otherwise.

All references to “State Materials Laboratory” shall be revised to read “Contracting Agency designated location”.

All references to “final contract voucher certification” shall be interpreted to mean the Contracting Agency form(s) by which final payment is authorized, and final completion and acceptance granted.

Additive

A supplemental unit of work or group of bid items, identified separately in the Bid Proposal, which may, at the discretion of the Contracting Agency, be awarded in addition to the base bid.

Alternate

One of two or more units of work or groups of bid items, identified separately in the Bid Proposal, from which the Contracting Agency may make a choice between different methods or material of construction for performing the same work.

Business Day

A business day is any day from Monday through Friday except holidays as listed in Section 1-08.5.

Contract Bond

The definition in the Standard Specifications for “Contract Bond” applies to whatever bond form(s) are required by the Contract Documents, which may be a combination of a Payment Bond and a Performance Bond.

Contract Documents

See definition for “Contract”.

Contract Time

The period of time established by the terms and conditions of the Contract within which the Work must be physically completed.

Notice of Award

The written notice from the Contracting Agency to the successful Bidder signifying the Contracting Agency’s acceptance of the Bid Proposal.

Notice to Proceed

The written notice from the Contracting Agency or Engineer to the Contractor authorizing and directing the Contractor to proceed with the Work and establishing the date on which the Contract time begins.

Traffic

Both vehicular and non-vehicular traffic, such as pedestrians, bicyclists, wheelchairs, and equestrian traffic.

1-02 BID PROCEDURES AND CONDITIONS**1-02.1 Prequalification of Bidders**

Delete this section and replace it with the following:

1-02.1 Qualifications of Bidder
(January 24, 2011 APWA GSP)

Before award of a public works contract, a bidder must meet at least the minimum qualifications of RCW 39.04.350(1) to be considered a responsible bidder and qualified to be awarded a public works project.

1-02.2 Plans and Specifications

(June 27, 2011 APWA GSP)

Delete this section and replace it with the following:

Information as to where Bid Documents can be obtained or reviewed can be found in the Call for Bids (Advertisement for Bids) for the work.

After award of the contract, plans and specifications will be issued to the Contractor at no cost as detailed below:

To Prime Contractor	No. of Sets	Basis of Distribution
Reduced plans (11" x 17")	5	Furnished automatically upon award.
Contract Provisions	5	Furnished automatically upon award.
Large plans (e.g., 22" x 34")	1	Furnished only upon request.

Additional plans and Contract Provisions may be obtained by the Contractor from the source stated in the Call for Bids, at the Contractor's own expense.

1-02.5 Proposal Forms

(July 31, 2017 APWA GSP)

Delete this section and replace it with the following:

The Proposal Form will identify the project and its location and describe the work. It will also list estimated quantities, units of measurement, the items of work, and the materials to be furnished at the unit bid prices. The bidder shall complete spaces on the proposal form that call for, but are not limited to, unit prices; extensions; summations; the total bid amount; signatures; date; and, where applicable, retail sales taxes and acknowledgment of addenda; the bidder's name, address, telephone number, and signature; the bidder's UDBE/DBE/M/WBE commitment, if applicable; a State of Washington Contractor's Registration Number; and a Business License Number, if applicable. Bids shall be completed by typing or shall be printed in ink by hand, preferably in black ink. The required certifications are included as part of the Proposal Form.

The Contracting Agency reserves the right to arrange the proposal forms with alternates and additives, if such be to the advantage of the Contracting Agency. The bidder shall bid on all alternates and additives set forth in the Proposal Form unless otherwise specified.

1-02.7 Bid Deposit

(March 8, 2013 APWA GSP)

Supplement this section with the following:

Bid bonds shall contain the following:

1. Contracting Agency-assigned number for the project;
2. Name of the project;
3. The Contracting Agency named as obligee;
4. The amount of the bid bond stated either as a dollar figure or as a percentage which represents five percent of the maximum bid amount that could be awarded;
5. Signature of the bidder's officer empowered to sign official statements. The signature of the person authorized to submit the bid should agree with the signature on the bond, and the title of the person must accompany the said signature;
6. The signature of the surety's officer empowered to sign the bond and the power of attorney.

If so stated in the Contract Provisions, bidder must use the bond form included in the Contract Provisions.

If so stated in the Contract Provisions, cash will not be accepted for a bid deposit.

1-02.9 Delivery of Proposal

Delete this section and replace it with the following:

Each Proposal shall be submitted in PDF format via electronic transmission to the Public Works email address at: publicworks@mercerisland.gov, by the date and time shown in the Advertisement for Bids.

1-02.10 Withdrawing, Revising, or Supplementing Proposal

(July 23, 2015 APWA GSP)

Delete this section, and replace it with the following:

1. After submitting a physical Bid Proposal to the Contracting Agency, the Bidder may withdraw, revise, or supplement it if:
 - a. The Bidder submits a written request signed by an authorized person and physically delivers it to the place designated for receipt of Bid Proposals, and
 - b. The Contracting Agency receives the request before the time set for receipt of Bid Proposals, and
 - c. The revised or supplemented Bid Proposal (if any) is received by the Contracting Agency before the time set for receipt of Bid Proposals.
2. If the Bidder's request to withdraw, revise, or supplement its Bid Proposal is received before the time set for receipt of Bid Proposals, the Contracting Agency will return the unopened Proposal package to the Bidder. The Bidder must then submit the revised or supplemented package in its entirety. If the Bidder does not submit a revised or supplemented package, then its bid shall be considered withdrawn.
3. Late revised or supplemented Bid Proposals or late withdrawal requests will be date recorded by the Contracting Agency and returned unopened. Mailed, emailed, or faxed requests to withdraw, revise, or supplement a Bid Proposal are not acceptable.

1-02.13 Irregular Proposals

(December 30, 2022 APWA GSP)

Delete this section and replace it with the following:

1. A Proposal will be considered irregular and will be rejected if:
 - a. The Bidder is not prequalified when so required;
 - b. The authorized Proposal form furnished by the Contracting Agency is not used or is altered;
 - c. The completed Proposal form contains any unauthorized additions, deletions, alternate Bids, or conditions;
 - d. The Bidder adds provisions reserving the right to reject or accept the award, or enter into the Contract;
 - e. A price per unit cannot be determined from the Bid Proposal;
 - f. The Proposal form is not properly executed;
 - g. The Bidder fails to submit or properly complete a subcontractor list (WSDOT Form 271-015), if applicable, as required in Section 1-02.6;
 - h. The Bidder fails to submit or properly complete a Disadvantaged Business Enterprise Certification (WSDOT Form 272-056), if applicable, as required in Section 1-02.6;

- i. The Bidder fails to submit Written Confirmations (WSDOT Form 422-031) from each DBE firm listed on the Bidder's completed DBE Utilization Certification that they are in agreement with the bidder's DBE participation commitment, if applicable, as required in Section 1-02.6, or if the written confirmation that is submitted fails to meet the requirements of the Special Provisions;
 - j. The Bidder fails to submit DBE Good Faith Effort documentation, if applicable, as required in Section 1-02.6, or if the documentation that is submitted fails to demonstrate that a Good Faith Effort to meet the Condition of Award was made;
 - k. The Bidder fails to submit a DBE Bid Item Breakdown (WSDOT Form 272-054), if applicable, as required in Section 1-02.6, or if the documentation that is submitted fails to meet the requirements of the Special Provisions;
 - l. The Bidder fails to submit DBE Trucking Credit Forms (WSDOT Form 272-058), if applicable, as required in Section 1-02.6, or if the documentation that is submitted fails to meet the requirements of the Special Provisions;
 - m. The Bid Proposal does not constitute a definite and unqualified offer to meet the material terms of the Bid invitation; or
 - n. More than one Proposal is submitted for the same project from a Bidder under the same or different names.
2. A Proposal may be considered irregular and may be rejected if:
- a. The Proposal does not include a unit price for every Bid item;
 - b. Any of the unit prices are excessively unbalanced (either above or below the amount of a reasonable Bid) to the potential detriment of the Contracting Agency;
 - c. Receipt of Addenda is not acknowledged;
 - d. A member of a joint venture or partnership and the joint venture or partnership submit Proposals for the same project (in such an instance, both Bids may be rejected); or
 - e. If Proposal form entries are not made in ink.

1-02.14 Disqualification of Bidders

(May 17, 2018 APWA GSP, Option A)

Delete this section and replace it with the following:

A Bidder will be deemed not responsible if the Bidder does not meet the mandatory bidder responsibility criteria in RCW 39.04.350(1), as amended.

The Contracting Agency will verify that the Bidder meets the mandatory bidder responsibility criteria in RCW 39.04.350(1). To assess bidder responsibility, the Contracting Agency reserves the right to request documentation as needed from the Bidder and third parties concerning the Bidder's compliance with the mandatory bidder responsibility criteria.

If the Contracting Agency determines the Bidder does not meet the mandatory bidder responsibility criteria in RCW 39.04.350(1) and is therefore not a responsible Bidder, the

Contracting Agency shall notify the Bidder in writing, with the reasons for its determination. If the Bidder disagrees with this determination, it may appeal the determination within two (2) business days of the Contracting Agency's determination by presenting its appeal and any additional information to the Contracting Agency. The Contracting Agency will consider the appeal and any additional information before issuing its final determination. If the final determination affirms that the Bidder is not responsible, the Contracting Agency will not execute a contract with any other Bidder until at least two business days after the Bidder determined to be not responsible has received the Contracting Agency's final determination.

1-02.15 Pre Award Information

(December 30, 2022 APWA GSP)

Revise this section to read:

Before awarding any contract, the Contracting Agency may require one or more of these items or actions of the apparent lowest responsible bidder:

1. A complete statement of the origin, composition, and manufacture of any or all materials to be used,
2. Samples of these materials for quality and fitness tests,
3. A progress schedule (in a form the Contracting Agency requires) showing the order of and time required for the various phases of the work,
4. A breakdown of costs assigned to any bid item,
5. Attendance at a conference with the Engineer or representatives of the Engineer,
6. Obtain, and furnish a copy of, a business license to do business in the city or county where the work is located.
7. Any other information or action taken that is deemed necessary to ensure that the bidder is the lowest responsible bidder.

1-03 AWARD AND EXECUTION OF THE CONTRACT

1-03.4 Contract Bond

(July 23, 2015 APWA GSP)

Delete the first paragraph and replace it with the following:

The successful bidder shall provide executed payment and performance bond(s) for the full contract amount. The bond may be a combined payment and performance bond; or be separate payment and performance bonds. In the case of separate payment and performance bonds, each shall be for the full contract amount. The bond(s) shall:

1. Be on Contracting Agency-furnished form(s);
2. Be signed by an approved surety (or sureties) that:
 - a. Is registered with the Washington State Insurance Commissioner, and

- b. Appears on the current Authorized Insurance List in the State of Washington published by the Office of the Insurance Commissioner,
- 3. Guarantee that the Contractor will perform and comply with all obligations, duties, and conditions under the Contract, including but not limited to the duty and obligation to indemnify, defend, and protect the Contracting Agency against all losses and claims related directly or indirectly from any failure:
 - a. Of the Contractor (or any of the employees, subcontractors, or lower tier subcontractors of the Contractor) to faithfully perform and comply with all contract obligations, conditions, and duties, or
 - b. Of the Contractor (or the subcontractors or lower tier subcontractors of the Contractor) to pay all laborers, mechanics, subcontractors, lower tier subcontractors, material person, or any other person who provides supplies or provisions for carrying out the work;
- 4. Be conditioned upon the payment of taxes, increases, and penalties incurred on the project under titles 50, 51, and 82 RCW; and
- 5. Be accompanied by a power of attorney for the Surety's officer empowered to sign the bond; and
- 6. Be signed by an officer of the Contractor empowered to sign official statements (sole proprietor or partner). If the Contractor is a corporation, the bond(s) must be signed by the president or vice president, unless accompanied by written proof of the authority of the individual signing the bond(s) to bind the corporation (i.e., corporate resolution, power of attorney, or a letter to such effect signed by the president or vice president).

1-03.7 Judicial Review

(December 30, 2022 APWA GSP)

Revise this section to read:

All decisions made by the Contracting Agency regarding the Award and execution of the Contract or Bid rejection shall be conclusive subject to the scope of judicial review permitted under Washington Law. Such review, if any, shall be timely filed in the Superior Court of the county where the Contracting Agency headquarters is located, provided that where an action is asserted against a county, RCW 36.01.050 shall control venue and jurisdiction.

1-04 SCOPE of WORK

1-04.2 Coordination of Contract Documents, Plans, Special Provisions, Specifications, and Addenda

(December 30, 2022 APWA GSP)

Revise the second paragraph to read:

Any inconsistency in the parts of the contract shall be resolved by following this order of precedence (e.g., 1 presiding over 2, 2 over 3, 3 over 4, and so forth):

- 1. Addenda,

2. Proposal Form,
3. Special Provisions,
4. Contract Plans,
5. Standard Specifications,
6. Contracting Agency's Standard Plans or Details (if any), and
7. WSDOT Standard Plans for Road, Bridge, and Municipal Construction.

1-05 CONTROL OF WORK

1-05.7 Removal of Defective and Unauthorized Work

(October 1, 2005 APWA GSP)

Supplement this section with the following:

If the Contractor fails to remedy defective or unauthorized work within the time specified in a written notice from the Engineer, or fails to perform any part of the work required by the Contract Documents, the Engineer may correct and remedy such work as may be identified in the written notice, with Contracting Agency forces or by such other means as the Contracting Agency may deem necessary.

If the Contractor fails to comply with a written order to remedy what the Engineer determines to be an emergency situation, the Engineer may have the defective and unauthorized work corrected immediately, have the rejected work removed and replaced, or have work the Contractor refuses to perform completed by using Contracting Agency or other forces. An emergency situation is any situation when, in the opinion of the Engineer, a delay in its remedy could be potentially unsafe, or might cause serious risk of loss or damage to the public.

Direct or indirect costs incurred by the Contracting Agency attributable to correcting and remedying defective or unauthorized work, or work the Contractor failed or refused to perform, shall be paid by the Contractor. Payment will be deducted by the Engineer from monies due, or to become due, the Contractor. Such direct and indirect costs shall include in particular, but without limitation, compensation for additional professional services required, and costs for repair and replacement of work of others destroyed or damaged by correction, removal, or replacement of the Contractor's unauthorized work.

No adjustment in contract time or compensation will be allowed because of the delay in the performance of the work attributable to the exercise of the Contracting Agency's rights provided by this Section.

The rights exercised under the provisions of this section shall not diminish the Contracting Agency's right to pursue any other avenue for additional remedy or damages with respect to the Contractor's failure to perform the work as required.

1-05.11 Final Inspection

Delete this section and replace it with the following:

1-05.11 Final Inspections and Operational Testing
(October 1, 2005 APWA GSP)

1-05.11(1) Substantial Completion Date

When the Contractor considers the work to be substantially complete, the Contractor shall so notify the Engineer and request the Engineer establish the Substantial Completion Date. The Contractor's request shall list the specific items of work that remain to be completed in order to reach physical completion. The Engineer will schedule an inspection of the work with the Contractor to determine the status of completion. The Engineer may also establish the Substantial Completion Date unilaterally.

If, after this inspection, the Engineer concurs with the Contractor that the work is substantially complete and ready for its intended use, the Engineer, by written notice to the Contractor, will set the Substantial Completion Date. If, after this inspection the Engineer does not consider the work substantially complete and ready for its intended use, the Engineer will, by written notice, so notify the Contractor giving the reasons therefor.

Upon receipt of written notice concurring in or denying substantial completion, whichever is applicable, the Contractor shall pursue vigorously, diligently and without unauthorized interruption, the work necessary to reach Substantial and Physical Completion. The Contractor shall provide the Engineer with a revised schedule indicating when the Contractor expects to reach substantial and physical completion of the work.

The above process shall be repeated until the Engineer establishes the Substantial Completion Date and the Contractor considers the work physically complete and ready for final inspection.

1-05.11(2) Final Inspection and Physical Completion Date

When the Contractor considers the work physically complete and ready for final inspection, the Contractor by written notice, shall request the Engineer to schedule a final inspection. The Engineer will set a date for final inspection. The Engineer and the Contractor will then make a final inspection and the Engineer will notify the Contractor in writing of all particulars in which the final inspection reveals the work incomplete or unacceptable. The Contractor shall immediately take such corrective measures as are necessary to remedy the listed deficiencies. Corrective work shall be pursued vigorously, diligently, and without interruption until physical completion of the listed deficiencies. This process will continue until the Engineer is satisfied the listed deficiencies have been corrected.

If action to correct the listed deficiencies is not initiated within 7 days after receipt of the written notice listing the deficiencies, the Engineer may, upon written notice to the Contractor, take whatever steps are necessary to correct those deficiencies pursuant to Section 1-05.7.

The Contractor will not be allowed an extension of contract time because of a delay in the performance of the work attributable to the exercise of the Engineer's right hereunder.

Upon correction of all deficiencies, the Engineer will notify the Contractor and the Contracting Agency, in writing, of the date upon which the work was considered physically complete. That date shall constitute the Physical Completion Date of the contract, but shall not imply acceptance of the work or that all the obligations of the Contractor under the contract have been fulfilled.

1-05.11(3) Operational Testing

It is the intent of the Contracting Agency to have at the Physical Completion Date a complete and operable system. Therefore when the work involves the installation of machinery or other mechanical equipment; street lighting, electrical distribution or signal systems; irrigation systems; buildings; or other similar work it may be desirable for the Engineer to have the Contractor operate and test the work for a period of time after final inspection but prior to the physical completion date. Whenever items of work are listed in the Contract Provisions for operational testing they shall be fully tested under operating conditions for the time period specified to ensure their acceptability prior to the Physical Completion Date. During and following the test period, the Contractor shall correct any items of workmanship, materials, or equipment which prove faulty, or that are not in first class operating condition. Equipment, electrical controls, meters, or other devices and equipment to be tested during this period shall be tested under the observation of the Engineer, so that the Engineer may determine their suitability for the purpose for which they were installed. The Physical Completion Date cannot be established until testing and corrections have been completed to the satisfaction of the Engineer.

The costs for power, gas, labor, material, supplies, and everything else needed to successfully complete operational testing, shall be included in the unit contract prices related to the system being tested, unless specifically set forth otherwise in the proposal.

Operational and test periods, when required by the Engineer, shall not affect a manufacturer's guaranties or warranties furnished under the terms of the contract.

1-05.13 Superintendents, Labor and Equipment of Contractor

(August 14, 2013 APWA GSP)

Delete the sixth and seventh paragraphs of this section.

1-05.15 Method of Serving Notices

(December 30, 2022 APWA GSP)

Revise the second paragraph to read:

All correspondence from the Contractor shall be directed to the Project Engineer. All correspondence from the Contractor constituting any notification, notice of protest, notice of dispute, or other correspondence constituting notification required to be furnished under the Contract, must be in paper format, hand delivered or sent via mail delivery service to

the Project Engineer's office. Electronic copies such as e-mails or electronically delivered copies of correspondence will not constitute such notice and will not comply with the requirements of the Contract.

1-05.16 Water and Power

(October 1, 2005 APWA GSP)

The Contractor shall make necessary arrangements, and shall bear the costs for power and water necessary for the performance of the work, unless the contract includes power and water as a pay item.

1-07 LEGAL RELATIONS AND RESPONSIBILITY TO THE PUBLIC

1-07.1 Laws to be Observed

(October 1, 2005 APWA GSP)

Supplement this section with the following:

In cases of conflict between different safety regulations, the more stringent regulation shall apply.

The Washington State Department of Labor and Industries shall be the sole and paramount administrative agency responsible for the administration of the provisions of the Washington Industrial Safety and Health Act of 1973 (WISHA).

The Contractor shall maintain at the project site office, or other well known place at the project site, all articles necessary for providing first aid to the injured. The Contractor shall establish, publish, and make known to all employees, procedures for ensuring immediate removal to a hospital, or doctor's care, persons, including employees, who may have been injured on the project site. Employees should not be permitted to work on the project site before the Contractor has established and made known procedures for removal of injured persons to a hospital or a doctor's care.

The Contractor shall have sole responsibility for the safety, efficiency, and adequacy of the Contractor's plant, appliances, and methods, and for any damage or injury resulting from their failure, or improper maintenance, use, or operation. The Contractor shall be solely and completely responsible for the conditions of the project site, including safety for all persons and property in the performance of the work. This requirement shall apply continuously, and not be limited to normal working hours. The required or implied duty of the Engineer to conduct construction review of the Contractor's performance does not, and shall not, be intended to include review and adequacy of the Contractor's safety measures in, on, or near the project site.

1-07.2 State Taxes

Delete this section, including its sub-sections, in its entirety and replace it with the following:

1-07.2 State Sales Tax

(June 27, 2011 APWA GSP)

The Washington State Department of Revenue has issued special rules on the State sales tax. Sections 1-07.2(1) through 1-07.2(3) are meant to clarify those rules. The Contractor should contact the Washington State Department of Revenue for answers to questions in this area. The Contracting Agency will not adjust its payment if the Contractor bases a bid on a misunderstood tax liability.

The Contractor shall include all Contractor-paid taxes in the unit bid prices or other contract amounts. In some cases, however, state retail sales tax will not be included. Section 1-07.2(2) describes this exception.

The Contracting Agency will pay the retained percentage (or release the Contract Bond if a FHWA-funded Project) only if the Contractor has obtained from the Washington State Department of Revenue a certificate showing that all contract-related taxes have been paid (RCW 60.28.051). The Contracting Agency may deduct from its payments to the Contractor any amount the Contractor may owe the Washington State Department of Revenue, whether the amount owed relates to this contract or not. Any amount so deducted will be paid into the proper State fund.

1-07.2(1) State Sales Tax — Rule 171

WAC 458-20-171, and its related rules, apply to building, repairing, or improving streets, roads, etc., which are owned by a municipal corporation, or political subdivision of the state, or by the United States, and which are used primarily for foot or vehicular traffic. This includes storm or combined sewer systems within and included as a part of the street or road drainage system and power lines when such are part of the roadway lighting system. For work performed in such cases, the Contractor shall include Washington State Retail Sales Taxes in the various unit bid item prices, or other contract amounts, including those that the Contractor pays on the purchase of the materials, equipment, or supplies used or consumed in doing the work.

1-07.2(2) State Sales Tax — Rule 170

WAC 458-20-170, and its related rules, apply to the constructing and repairing of new or existing buildings, or other structures, upon real property. This includes, but is not limited to, the construction of streets, roads, highways, etc., owned by the state of Washington; water mains and their appurtenances; sanitary sewers and sewage disposal systems unless such sewers and disposal systems are within, and a part of, a street or road drainage system; telephone, telegraph, electrical power distribution lines, or other conduits or lines in or above streets or roads, unless such power lines become a part of a street or road lighting system; and installing or attaching of any article of tangible personal property in or

to real property, whether or not such personal property becomes a part of the realty by virtue of installation.

For work performed in such cases, the Contractor shall collect from the Contracting Agency, retail sales tax on the full contract price. The Contracting Agency will automatically add this sales tax to each payment to the Contractor. For this reason, the Contractor shall not include the retail sales tax in the unit bid item prices, or in any other contract amount subject to Rule 170, with the following exception.

Exception: The Contracting Agency will not add in sales tax for a payment the Contractor or a subcontractor makes on the purchase or rental of tools, machinery, equipment, or consumable supplies not integrated into the project. Such sales taxes shall be included in the unit bid item prices or in any other contract amount.

1-07.2(3) Services

The Contractor shall not collect retail sales tax from the Contracting Agency on any contract wholly for professional or other services (as defined in Washington State Department of Revenue Rules 138 and 244).

1-07.18 Public Liability and Property Damage Insurance

Delete this section in its entirety, and replace it with the following:

1-07.18 Insurance

(December 30, 2022 APWA GSP)

1-07.18(1) General Requirements

- A. The Contractor shall procure and maintain the insurance described in all subsections of section 1-07.18 of these Special Provisions, from insurers with a current A. M. Best rating of not less than A-: VII and licensed to do business in the State of Washington. The Contracting Agency reserves the right to approve or reject the insurance provided, based on the insurer's financial condition.
- B. The Contractor shall keep this insurance in force without interruption from the commencement of the Contractor's Work through the term of the Contract and for thirty (30) days after the Physical Completion date, unless otherwise indicated below.
- C. If any insurance policy is written on a claims-made form, its retroactive date, and that of all subsequent renewals, shall be no later than the effective date of this Contract. The policy shall state that coverage is claims made and state the retroactive date. Claims-made form coverage shall be maintained by the Contractor for a minimum of 36 months following the Completion Date or earlier termination of this Contract, and the Contractor shall annually provide the Contracting Agency with proof of renewal. If renewal of the claims made form of coverage becomes unavailable, or economically prohibitive, the Contractor shall purchase an extended reporting period ("tail") or execute another form of guarantee acceptable to the Contracting Agency to assure financial responsibility for liability for services performed.

- D. The Contractor's Automobile Liability, Commercial General Liability and Excess or Umbrella Liability insurance policies shall be primary and non-contributory insurance as respects the Contracting Agency's insurance, self-insurance, or self-insured pool coverage. Any insurance, self-insurance, or self-insured pool coverage maintained by the Contracting Agency shall be excess of the Contractor's insurance and shall not contribute with it.
- E. The Contractor shall provide the Contracting Agency and all additional insureds with written notice of any policy cancellation, within two business days of their receipt of such notice.
- F. The Contractor shall not begin work under the Contract until the required insurance has been obtained and approved by the Contracting Agency
- G. Failure on the part of the Contractor to maintain the insurance as required shall constitute a material breach of contract, upon which the Contracting Agency may, after giving five business days' notice to the Contractor to correct the breach, immediately terminate the Contract or, at its discretion, procure or renew such insurance and pay any and all premiums in connection therewith, with any sums so expended to be repaid to the Contracting Agency on demand, or at the sole discretion of the Contracting Agency, offset against funds due the Contractor from the Contracting Agency.
- H. All costs for insurance shall be incidental to and included in the unit or lump sum prices of the Contract and no additional payment will be made.

1-07.18(2) Additional Insured

All insurance policies, with the exception of Workers Compensation, and of Professional Liability and Builder's Risk (if required by this Contract) shall name the following listed entities as additional insured(s) using the forms or endorsements required herein:

- the Contracting Agency and its officers, elected officials, employees, agents, and volunteers

The above-listed entities shall be additional insured(s) for the full available limits of liability maintained by the Contractor, irrespective of whether such limits maintained by the Contractor are greater than those required by this Contract, and irrespective of whether the Certificate of Insurance provided by the Contractor pursuant to 1-07.18(4) describes limits lower than those maintained by the Contractor.

For Commercial General Liability insurance coverage, the required additional insured endorsements shall be at least as broad as ISO forms CG 20 10 10 01 for ongoing operations and CG 20 37 10 01 for completed operations.

1-07.18(3) Subcontractors

The Contractor shall cause each subcontractor of every tier to provide insurance coverage that complies with all applicable requirements of the Contractor-provided insurance as set forth herein, except the Contractor shall have sole responsibility for determining the limits of coverage required to be obtained by subcontractors.

The Contractor shall ensure that all subcontractors of every tier add all entities listed in 1-07.18(2) as additional insureds, and provide proof of such on the policies as required by that

section as detailed in 1-07.18(2) using an endorsement as least as broad as ISO CG 20 10 10 01 for ongoing operations and CG 20 37 10 01 for completed operations.

Upon request by the Contracting Agency, the Contractor shall forward to the Contracting Agency evidence of insurance and copies of the additional insured endorsements of each subcontractor of every tier as required in 1-07.18(4) Verification of Coverage.

1-07.18(4) Verification of Coverage

The Contractor shall deliver to the Contracting Agency a Certificate(s) of Insurance and endorsements for each policy of insurance meeting the requirements set forth herein when the Contractor delivers the signed Contract for the work. Failure of Contracting Agency to demand such verification of coverage with these insurance requirements or failure of Contracting Agency to identify a deficiency from the insurance documentation provided shall not be construed as a waiver of Contractor's obligation to maintain such insurance.

Verification of coverage shall include:

1. An ACORD certificate or a form determined by the Contracting Agency to be equivalent.
2. Copies of all endorsements naming Contracting Agency and all other entities listed in 1-07.18(2) as additional insured(s), showing the policy number. The Contractor may submit a copy of any blanket additional insured clause from its policies instead of a separate endorsement.
3. Any other amendatory endorsements to show the coverage required herein.
4. A notation of coverage enhancements on the Certificate of Insurance shall not satisfy these requirements – actual endorsements must be submitted.

Upon request by the Contracting Agency, the Contractor shall forward to the Contracting Agency a full and certified copy of the insurance policy(s). If Builders Risk insurance is required on this Project, a full and certified copy of that policy is required when the Contractor delivers the signed Contract for the work.

1-07.18(5) Coverages and Limits

The insurance shall provide the minimum coverages and limits set forth below. Contractor's maintenance of insurance, its scope of coverage, and limits as required herein shall not be construed to limit the liability of the Contractor to the coverage provided by such insurance, or otherwise limit the Contracting Agency's recourse to any remedy available at law or in equity.

All deductibles and self-insured retentions must be disclosed and are subject to approval by the Contracting Agency. The cost of any claim payments falling within the deductible or self-insured retention shall be the responsibility of the Contractor. In the event an additional insured incurs a liability subject to any policy's deductibles or self-insured retention, said deductibles or self-insured retention shall be the responsibility of the Contractor.

1-07.18(5)A Commercial General Liability

Commercial General Liability insurance shall be written on coverage forms at least as broad as ISO occurrence form CG 00 01, including but not limited to liability arising from premises, operations, stop gap liability, independent contractors, products-completed operations,

personal and advertising injury, and liability assumed under an insured contract. There shall be no exclusion for liability arising from explosion, collapse or underground property damage.

The Commercial General Liability insurance shall be endorsed to provide a per project general aggregate limit, using ISO form CG 25 03 05 09 or an equivalent endorsement.

Contractor shall maintain Commercial General Liability Insurance arising out of the Contractor's completed operations for at least three years following Substantial Completion of the Work.

Such policy must provide the following minimum limits:

\$1,000,000	Each Occurrence
\$2,000,000	General Aggregate
\$2,000,000	Products & Completed Operations Aggregate
\$1,000,000	Personal & Advertising Injury each offence
\$1,000,000	Stop Gap / Employers' Liability each accident

1-07.18(5)B Automobile Liability

Automobile Liability shall cover owned, non-owned, hired, and leased vehicles; and shall be written on a coverage form at least as broad as ISO form CA 00 01. If the work involves the transport of pollutants, the automobile liability policy shall include MCS 90 and CA 99 48 endorsements.

Such policy must provide the following minimum limit:

\$1,000,000	Combined single limit each accident
-------------	-------------------------------------

1-07.18(5)C Workers' Compensation

The Contractor shall comply with Workers' Compensation coverage as required by the Industrial Insurance laws of the State of Washington.

1-08 PROSECUTION AND PROGRESS

Add the following new section:

1-08.0 Preliminary Matters

(May 25, 2006 APWA GSP)

Add the following new section:

1-08.0(1) Preconstruction Conference

(October 10, 2008 APWA GSP)

Prior to the Contractor beginning the work, a preconstruction conference will be held between the Contractor, the Engineer and such other interested parties as may be invited.

The purpose of the preconstruction conference will be:

1. To review the initial progress schedule;
2. To establish a working understanding among the various parties associated or affected by the work;

3. To establish and review procedures for progress payment, notifications, approvals, submittals, etc.;
4. To establish normal working hours for the work;
5. To review safety standards and traffic control; and
6. To discuss such other related items as may be pertinent to the work.

The Contractor shall prepare and submit at the preconstruction conference the following:

1. A breakdown of all lump sum items;
2. A preliminary schedule of working drawing submittals; and
3. A list of material sources for approval if applicable.

Add the following new section:

1-08.0(2) Hours of Work

(December 8, 2014 APWA GSP)

Except in the case of emergency or unless otherwise approved by the Engineer, the normal working hours for the Contract shall be any consecutive 8-hour period between 7:00 a.m. and 6:00 p.m. Monday through Friday, exclusive of a lunch break. If the Contractor desires different than the normal working hours stated above, the request must be submitted in writing prior to the preconstruction conference, subject to the provisions below. The working hours for the Contract shall be established at or prior to the preconstruction conference.

All working hours and days are also subject to local permit and ordinance conditions (such as noise ordinances).

If the Contractor wishes to deviate from the established working hours, the Contractor shall submit a written request to the Engineer for consideration. This request shall state what hours are being requested, and why. Requests shall be submitted for review no later than five (5) days prior to the day(s) the Contractor is requesting to change the hours.

If the Contracting Agency approves such a deviation, such approval may be subject to certain other conditions, which will be detailed in writing. For example:

1. On non-Federal aid projects, requiring the Contractor to reimburse the Contracting Agency for the costs in excess of straight-time costs for Contracting Agency representatives who worked during such times. (The Engineer may require designated representatives to be present during the work. Representatives who may be deemed necessary by the Engineer include, but are not limited to: survey crews; personnel from the Contracting Agency's material testing lab; inspectors; and other Contracting Agency employees or third party consultants when, in the opinion of the Engineer, such work necessitates their presence.)
2. Considering the work performed on Saturdays, Sundays, and holidays as working days with regard to the contract time.
3. Considering multiple work shifts as multiple working days with respect to contract time even though the multiple shifts occur in a single 24-hour period.

4. If a 4-10 work schedule is requested and approved the non working day for the week will be charged as a working day.
5. If Davis Bacon wage rates apply to this Contract, all requirements must be met and recorded properly on certified payroll

1-08.3(2)A Type A Progress Schedule

(December 30, 2022 APWA GSP)

Revise this section to read:

The Contractor shall submit two (2) copies of a Type A Progress Schedule no later than at the preconstruction conference, or some other mutually agreed upon submittal time. The schedule may be a critical path method (CPM) schedule, bar chart, or other standard schedule format. Regardless of which format used, the schedule shall identify the critical path. The Engineer will evaluate the Type A Progress Schedule and approve or return the schedule for corrections within 15 calendar days of receiving the submittal.

1-08.4 Prosecution of Work

Delete this section and replace it with the following:

1-08.4 Notice to Proceed and Prosecution of Work

(July 23, 2015 APWA GSP)

Notice to Proceed will be given after the contract has been executed and the contract bond and evidence of insurance have been approved and filed by the Contracting Agency. The Contractor shall not commence with the work until the Notice to Proceed has been given by the Engineer. The Contractor shall commence construction activities on the project site within ten days of the Notice to Proceed Date, unless otherwise approved in writing. The Contractor shall diligently pursue the work to the physical completion date within the time specified in the contract. Voluntary shutdown or slowing of operations by the Contractor shall not relieve the Contractor of the responsibility to complete the work within the time(s) specified in the contract.

When shown in the Plans, the first order of work shall be the installation of high visibility fencing to delineate all areas for protection or restoration, as described in the Contract. Installation of high visibility fencing adjacent to the roadway shall occur after the placement of all necessary signs and traffic control devices in accordance with 1-10.1(2). Upon construction of the fencing, the Contractor shall request the Engineer to inspect the fence. No other work shall be performed on the site until the Contracting Agency has accepted the installation of high visibility fencing, as described in the Contract.

1-08.5 Time for Completion

(December 30, 2022 APWA GSP, Option A)

Revise the third and fourth paragraphs to read:

Contract time shall begin on the first working day following the Notice to Proceed Date.

Each working day shall be charged to the contract as it occurs, until the contract work is physically complete. If substantial completion has been granted and all the authorized working days have been used, charging of working days will cease. Each week the Engineer will provide the Contractor a statement that shows the number of working days: (1) charged to the contract the week before; (2) specified for the physical completion of the contract; and (3) remaining for the physical completion of the contract. The statement will also show the nonworking days and all partial or whole days the Engineer declares as unworkable. The statement will be identified as a Written Determination by the Engineer. If the Contractor does not agree with the Written Determination of working days, the Contractor shall pursue the protest procedures in accordance with Section 1-04.5. By failing to follow the procedures of Section 1-04.5, the Contractor shall be deemed as having accepted the statement as correct. If the Contractor is approved to work 10 hours a day and 4 days a week (a 4-10 schedule) and the fifth day of the week in which a 4-10 shift is worked would ordinarily be charged as a working day then the fifth day of that week will be charged as a working day whether or not the Contractor works on that day.

Revise the sixth paragraph to read:

The Engineer will give the Contractor written notice of the completion date of the contract after all the Contractor's obligations under the contract have been performed by the Contractor. The following events must occur before the Completion Date can be established:

1. The physical work on the project must be complete; and
2. The Contractor must furnish all documentation required by the contract and required by law, to allow the Contracting Agency to process final acceptance of the contract. The following documents must be received by the Project Engineer prior to establishing a completion date:
 - a. Certified Payrolls (per Section 1-07.9(5)).
 - b. Material Acceptance Certification Documents
 - c. Monthly Reports of Amounts Credited as DBE Participation, as required by the Contract Provisions.
 - d. Final Contract Voucher Certification
 - e. Copies of the approved "Affidavit of Prevailing Wages Paid" for the Contractor and all Subcontractors
 - f. A copy of the Notice of Termination sent to the Washington State Department of Ecology (Ecology); the elapse of 30 calendar days from the date of receipt of the Notice of Termination by Ecology; and no rejection of the Notice of Termination by Ecology. This requirement will not apply if the Construction

Stormwater General Permit is transferred back to the Contracting Agency in accordance with Section 8-01.3(16).

- g. Property owner releases per Section 1-07.24

1-08.9 Liquidated Damages

(Special Provision)

Revise this section to read:

Time is of the essence of this contract. Delays inconvenience the residents of Mercer Island and cost taxpayers undue sums of money, adding time needed for administration, engineering, inspection and supervision. It is impractical for the City to calculate the actual cost of delays. Accordingly, the Contractor agrees to pay liquidated damages as follows: Liquidated damages for failure to achieve timely Substantial Completion shall be in the amount of \$250.00 per day.

1-09 MEASUREMENT AND PAYMENT

1-09.2(5) Measurement

(December 30, 2022 APWA GSP)

Revise the first paragraph to read:

Scale Verification Checks – At the Engineer’s discretion, the Engineer may perform verification checks on the accuracy of each batch, hopper, or platform scale used in weighing contract items of Work.

1-09.6 Force Account

(December 30, 2022 APWA GSP)

Supplement this section with the following:

The Contracting Agency has estimated and included in the Proposal, dollar amounts for all items to be paid per force account, only to provide a common proposal for Bidders. All such dollar amounts are to become a part of Contractor's total bid. However, the Contracting Agency does not warrant expressly or by implication, that the actual amount of work will correspond with those estimates. Payment will be made on the basis of the amount of work actually authorized by the Engineer.

1-09.7 Mobilization

(December 30, 2022 APWA GSP)

Delete this Section and replace it with the following:

Mobilization consists of preconstruction expenses and the costs of preparatory Work and operations performed by the Contractor typically occurring before 10 percent of the total

original amount of an individual Bid Schedule is earned from other Contract items on that Bid Schedule. Items which are not to be included in the item of Mobilization include but are not limited to:

1. Portions of the Work covered by the specific Contract item or incidental Work which is to be included in a Contract item or items.
2. Profit, interest on borrowed money, overhead, or management costs.
3. Costs incurred for mobilizing equipment for force account Work.

Based on the lump sum Contract price for "Mobilization", partial payments will be made as follows:

1. When 5 percent of the total original Bid Schedule amount is earned from other Contract items on that original Bid Schedule, excluding amounts paid for materials on hand, 50 percent of the Bid Item for mobilization on that original Bid Schedule, 5 percent of the total of that original Bid Schedule, or 5 percent of the total original Contract amount, whichever is the least, will be paid.
2. When 10 percent of the total original Bid Schedule amount is earned from other Contract items on that original Bid Schedule, excluding amounts paid for materials on hand, 100 percent of the Bid Item for mobilization on that original Bid Schedule, 10 percent of the total of that original Bid Schedule, or 10 percent of the total original Contract amount, whichever is the least, will be paid.
3. When the Substantial Completion Date has been established for the project, payment of any remaining amount Bid for mobilization will be paid.

Nothing herein shall be construed to limit or preclude partial payments otherwise provided by the Contract.

1-09.11(3) Time Limitation and Jurisdiction

(December 30, 2022 APWA GSP)

Revise this section to read:

For the convenience of the parties to the Contract it is mutually agreed by the parties that all claims or causes of action which the Contractor has against the Contracting Agency arising from the Contract shall be brought within 180 calendar days from the date of final acceptance (Section 1-05.12) of the Contract by the Contracting Agency; and it is further agreed that all such claims or causes of action shall be brought only in the Superior Court of the county where the Contracting Agency headquarters is located, provided that where an action is asserted against a county, RCW 36.01.050 shall control venue and jurisdiction. The parties understand and agree that the Contractor's failure to bring suit within the time period provided, shall be a complete bar to all such claims or causes of action. It is further mutually agreed by the parties that when claims or causes of action which the Contractor asserts against the Contracting Agency arising from the Contract are filed with the Contracting Agency or initiated in court, the Contractor shall permit the Contracting Agency to have timely access to all records deemed necessary by the Contracting Agency to assist in evaluating the claims or action.

1-09.13(3)A Arbitration General

(January 19, 2022 APWA GSP)

Revise the third paragraph to read:

The Contracting Agency and the Contractor mutually agree to be bound by the decision of the arbitrator, and judgment upon the award rendered by the arbitrator may be entered in the Superior Court of the county in which the Contracting Agency's headquarters is located, provided that where claims subject to arbitration are asserted against a county, RCW 36.01.050 shall control venue and jurisdiction of the Superior Court. The decision of the arbitrator and the specific basis for the decision shall be in writing. The arbitrator shall use the Contract as a basis for decisions.

1-10 TEMPORARY TRAFFIC CONTROL

1-10.4(2) Measurement

(Special Provision)

Supplement

"Traffic Control Labor" will be measured by the hour. Hours will be measured for activities performed under the description of "Flaggers" and "Other Traffic Control Labor", herein.

"Traffic Control Supervisor" will be measured by lump sum for activities performed under the description of "Traffic Control Supervisor".

1-10.5(2) Payment

(Special Provision)

Supplement

All traffic control devices, class B construction signs, the sign truck(s), and the Traffic Control Supervisor's truck will be **incidental** to related Bid items and no additional payments will be made.

Payment will be made for the following bid item(s):

"Traffic Control Labor", per hour.

The unit price per hour of "Traffic Control Labor" when applied to the number of units measured for this item in accordance with Section 1-10.4(2) shall be full compensation for all costs incurred by the Contractor for flagging activities and other traffic control activities as described in Section 1-10.3(1) of the Standard Specifications.

"Traffic Control Supervisor", per lump sum.

The lump sum price of "Traffic Control Supervisor" shall be full compensation for all costs incurred by the Contractor for Traffic Control Supervisor activities and other traffic control activities as described in Section 1-10.2(1)B of the Standard Specifications.

**DIVISION 2
EARTHWORK**

2-01 CLEARING, GRUBBING, AND ROADSIDE CLEANUP

2-01.1 Description

(Special Provision)

Supplement

The Contractor shall stake the proposed clearing limits at a minimum of fifty (50) foot intervals. The Contractor shall allow 48 hours for the Engineer to approve the clearing limits before commencing activities. At the direction of the Engineer, the limits shall be adjusted in the field. When staking the clearing limits, the Contractor shall strive to protect from damage existing landscaping items, such as vegetation, rockeries, irrigation and other items from damage.

2-01.2 Disposal of Usable Material and Debris

2-01.5 Payment

(Special Provision)

Supplement

All costs involved in obtaining and providing a waste site shall be considered **incidental** to other bid items.

Root pruning shall be **incidental** to other bid items.

2-02 REMOVAL OF STRUCTURES AND OBSTRUCTIONS

2-02.3 Construction Requirements

(Special Provision)

Supplement

Existing trees, landscaping and plantings, utility boxes, signs, meters, bollards, mailboxes, posts, etc. located near the construction which conflict with the Work shall be removed or relocated in a manner satisfactory to the Engineer to allow for construction.

2-02.3(3)1 Removing Asphalt or Cement Concrete Pavement

(Special Provision)

New Section

Existing asphalt concrete pavement shall be removed at the locations shown in the Plans and where designated by the Engineer. This Work shall be performed where shown in the Plans in accordance with Section 2-02.3(3) of the Standard Specifications and these Special Provisions.

Removal shall be accomplished by making a neat longitudinal vertical cut along the boundaries of the area to be removed. Sawcutting shall be accomplished as previously specified with a self-propelled machine capable of cutting the full pavement depth and approved by the Engineer. The use of pneumatic hammers or punches will not be permitted, unless sawcutting follows.

Removal of large pavement areas may be accomplished using a pavement grinder.

Care shall be taken in removing the pavement not to damage any of the existing pavement that is to remain in place. Any remaining asphalt or cement concrete pavement damaged due to the Contractor's operations shall be replaced by the Contractor, to the satisfaction of the Engineer at the Contractor's expense.

2-02.3(3)2 Removing Pavement Markings

(Special Provision)

New Section

Existing pavement markings including plastic stop bars, traffic letters, traffic arrows, and raised pavement markers shall be removed at all locations to receive asphalt overlay or as indicated in the Plans.

Removal of existing pavement markings shall be conducted using such methods to prevent damage to the remaining pavement. The use of chemicals that may be harmful to the pavement will not be allowed. Damaged pavement shall be replaced at the Contractor's expense.

Painted and thermoplastic pavement markings shall be removed by sandblasting, grinding, or other method approved by the Engineer. All markers to be removed shall be done without damaging the pavement.

Removing pavement markings shall include removing, loading, hauling, and disposing of the removed material.

2-02.3(3)3 Sawcutting

(Special Provision)

New Section

All pavements, curbs, gutters, sidewalks, and other surfacing materials to be removed shall be sawcut where removals abut other pavement areas to remain.

The Contractor shall include in the various other bid items all costs necessary to provide sawcutting as required by the Standard Specifications and these Special Provisions.

The Contractor shall be responsible for ensuring that special precautions are undertaken so that no concrete or concrete by-products, or products and by-products used in the sawcut of asphalt or concrete, are discharged into any storm drain or surface water system.

In accordance with the Department of Ecology guidelines, wastewater from Portland Cement Concrete, masonry, and asphalt concrete cutting operations shall not be discharged to storm drainage systems or surface waters. Cutting operations increase the pH of wastewater; therefore filtering prior to discharge is not acceptable.

To thoroughly clean sawcuts where necessary, the Contractor may use high pressure water (high pressure water is considered greater than 1400 psi).

All wastewater shall be collected using a wet-dry vacuum or pumped into drums for disposal. Disposal of the waste liquid may be to soil or other porous surfaces away from storm drains and

surface water, only if the Contractor collects and disposes of remaining sediment after water has filtered into soil or evaporated. Impervious surfaces contaminated with sediment and grit from cutting, planing or pulverizing operations shall be cleaned by sweepers to prevent contaminants from entering the storm drainage system or surface waters when it rains.

2-02.4 Measurement

(Special Provision)

Supplement

“Remove Asphalt Conc. Pavement” and “Remove Cement Conc. Pavement” shall be per square yard regardless of the pavement thickness. Items to be included in the bid price shall include, but shall not necessarily be limited to: sawcutting, removal, haul, and legal disposal of asphalt pavement, asphalt walkways, thickened edges, asphalt berms, cement concrete sidewalks, cement concrete driveways, and cement concrete curb ramps where shown on the Plans and specified herein.

“Remove Cement Conc. Curb” shall be per linear foot. Items to be included in the bid price shall include, but shall not necessarily be limited to: sawcutting, removal, haul, and legal disposal of cement concrete curb.

2-02.5 Payment

(Special Provision)

Supplement

All costs for removing pavement markings including removing, loading, hauling, and disposing of the removed material shall be considered **incidental** to and included in the various paving bid items and no additional payments will be made unless a bid item for the work is included in the Proposal.

All costs associated with sawcutting shall be considered **incidental** to and included in the unit contract price for the type of material to be removed or improvement to be installed. Collection of wasted water with vacuum system and pollution control shall be considered **incidental** to and included in the unit contract price for associated removal or improvement bid items which require sawcutting.

All costs for removing and resetting of miscellaneous items on or near the construction site shall be considered **incidental** to and included in the various bid items and no additional payments will be made unless a bid item for the Work is included in the Proposal.

Payment will be made for the following bid item(s):

“Remove Asphalt Conc. Pavement”, per square yard.

“Remove Cement Conc. Pavement”, per square yard.

“Remove Cement Conc. Curb”, per linear foot.

The contract bid price above, including all incidental Work, shall be full compensation for all labor, material, tools, and equipment necessary to satisfactorily complete the Work as defined in the Standard Specifications and these Special Provisions.

2-03 ROADWAY EXCAVATION AND EMBANKMENT

2-03.1 Description

(Special Provision)

Supplement

For the purposes of this contract, Roadway Excavation Incl. Haul shall be all excavation required for roadway grading areas, driveway approaches, and shoulder grading (where excess materials exist on shoulder areas, including sod and other organic material).

2-03.3 Construction Requirements

2-03.3(7)C Contractor-Provided Disposal Site

(Special Provision)

Supplement

No waste site has been provided by the City for the disposal of material and debris. The Contractor shall make all arrangements, at Contractor's expense, for the disposal of waste materials and shall protect the City from any and all damages arising therefrom.

2-03.4 Measurement

(Special Provision)

Supplement

"Roadway Excavation Incl. Haul" will be measured loose, in the haul truck, by cubic yard by visual inspection and agreed upon by the Engineer and Contractor.

2-03.5 Payment

(Special Provision)

Supplement

Payment for "Roadway Excavation Incl. Haul" shall be paid per cubic yard in the haul truck by visual inspection and agreed upon by the Engineer and Contractor.

2-06 SUBGRADE PREPARATION

2-06.1 Subgrade Preparation

(Special provision)

Supplement

Subgrade preparation shall include preparing roadbeds, shoulders, driveway approaches, driveways, or any other permanent hard surface improvement for base material or final surfacing.

2-06.3 Construction Requirements

(Special provision)

Supplement

The subgrade shall be shaped and maintained to drain at all times during construction, including temporary ditches, and modifications to drainage structures necessary to eliminate standing water on the subgrade.

Local traffic will be allowed on the subgrade during the period of subgrade exposure.

2-06.5 Payment

(Special provision)

Supplement

Compaction of the subgrade shall be considered **incidental** to and included in the unit contract prices of other items in the contract, and all costs thereof shall be included by the Contractor in other pay items.

All costs for protection of the subgrade, including replacement of damaged or contaminated suitable material, shall be considered **incidental** to and included in the unit contract prices for other items in the contract.

**DIVISION 3
PRODUCTION FROM QUARRY AND PIT SITES AND STOCKPILING**

3-01 PRODUCTION FROM QUARRY AND PIT SITES

3-01.4 Contractor Furnished Material Sources

(Special Provision)

Supplement

If the source of materials provided by the Contractor necessitates hauling over roads other than City streets, the Contractor shall at his or her own expense make all arrangements for the use of haul routes.

**DIVISION 4
BASES**

4-04 BALLAST AND CRUSHED SURFACING

4-04.2 Materials

Crushed Surfacing Top Course may be used as structural backfill, roadway and shoulder base material, and shoulder top dressing and restoration.

Crushed Surfacing Base Course may be substituted for Crushed Surfacing Top Course for the road base only and may not be used for shoulder restoration. Asphalt grindings may be substituted for Crushed Surfacing Base Course provided their gradation matches that of Crushed Surfacing Base Course. Any asphalt grindings used shall not be measured for payment.

4-04.3(4) Placing and Spreading

(Special Provision)

Supplement

After pavement removal the road base shall be spread, shaped, and compacted to conform to the widths, depths and cross-section slopes shown on the drawings. Additional Crushed Surfacing Top Course shall be added during the grading and compacting process as needed to achieve the required line, grade, and cross-slope.

4-04.4 Measurement

(Special Provision)

Supplement

“Crushed Surfacing Top Course (or Base Course)” shall be measured per ton.

4-04.5 Payment

(Special Provision)

Supplement

“Crushed Surfacing Top Course (or Base Course)”, per ton.

**DIVISION 5
SURFACE TREATMENTS AND PAVEMENTS**

5-04 HOT MIX ASPHALT

5-04.1 Description

(Special Provision)

Supplement

This Work also consists of roadway pavement repair, preleveling and surfacing, minor widening, driveway approaches, thickened edges, paved shoulders and speed bumps.

5-04.2 Materials

(Special Provision)

Supplement

The grade of asphalt binder used in HMA shall be PG 58H-22.

5-04.3 Construction Requirements

5-04.3(3) C Hot Mix Asphalt Pavers

(Special Provision)

Supplement

For construction of asphalt thickened edges, the paver shall be equipped with at least one adjustable strike-off plate or raised edge attachment as an integral part of the screed. The angle of the plate shall be mechanically adjustable to allow for raising or lowering of the plate while the paver is in motion. A fixed angle strike-off plate or bolt-on "shoe" beyond the screed is not an acceptable substitute.

5-04.3(3)D Material Transfer Device/Vehicle

(Special Provision)

Supplement

A material transfer device or vehicle will not be required on this contract.

5-04.3(4)C Pavement Repair

(Special Provision)

Supplement

Approximate limits of Pavement Repair Excavation have been shown on the Plans. Prior to the HMA overlay, the Engineer shall inspect the roadway surface with the Contractor to mark additional areas of Pavement Repair Excavation for which a unit cost bid item has been included. Pavement Repair Excavation shall consist of rotomilling the pavement repair area to a depth as shown on the plans up to a maximum of 8 inches below the existing pavement surface.

5-04.3(4)D Uses for HMA

(Special Provision)

New Section

Uses for HMA for Pavement Repair Cl. B shall include Work on Schedules A and B (Residential Overlays) and consist of multiple lifts of pavement repair in areas identified on the plans.

Uses for HMA for Paving Cl. B shall include Work on Schedules A and B (Residential Overlays) and shall consist of multiple roadway paving lifts, roadway widening, preleveling, driveways, thickened edge, berms, speed bumps, and adjustment to paved areas such as the back of shoulder, aprons/spillways, feathering joints, adjustment of utilities to grade, and other such uses as directed by the Engineer.

Uses for HMA for Pavement Repair Cl. ½" shall include Work on Schedule C (Pavement Repairs) and consist of multiple lifts of pavement repair in areas identified on the plans.

All uses for HMA shall be measured and paid by the ton.

5-04.3(14) Planing Bituminous Pavement

(Special Provision)

Supplement

Prior to opening to traffic, any delaminating of existing asphalt pavement shall be removed from the site and resulting holes shall be patched with HMA. Also, the surface shall be cleaned by sweeping to remove dust and loose materials. A pick-up type street sweeper shall be present at all times during planing operations. A vacuum type street sweeper shall be used at the end of each Work day involving planing operations.

Damage from planing beyond the planing limits or any other damage resulting from the Contractor's operations shall be repaired at the Contractor's expense.

Temporary asphalt ramps, constructed from either hot mix or cold mix asphalt materials, shall be placed along all transverse and longitudinal cuts in the roadway and all protruding utility castings exposed to vehicular traffic. Ramp material shall be removed just prior to paving Work. All temporary asphalt ramp Work shall be incidental to the paving and planing bid items.

The Contractor shall erect appropriate construction signage immediately following pavement planing operations to warn the traveling public of grade transitions, grooved pavement, bumps, abrupt edges, and any other hazard created by pavement planing Work. Signage shall remain in place until the hazard has been removed.

Once existing asphalt pavement surfaces have been planed, all areas must be paved back within 14 days.

5-04.4 Measurement

(Special Provision)

Supplement

"Planing Bituminous Pavement" will be measured by actual surface area planed, regardless of the width of the planer, up to a depth of 4".

"HMA for Pavement Repair Cl. ½'", "HMA for Pavement Repair Cl. B", and "HMA for Paving Cl. B" will be measured by the ton in accordance with Section 1-09.2 with no deduction being made for the weight of asphalt binder, blending sand, mineral filler or any other component of the mixture.

5-04.5 Payment

(Special Provision)

Supplement

Preparation of Untreated Roadway will be considered **incidental** and included in the various bid items and no additional payment will be made.

All costs associated with application of tack coat or Soil Residual Herbicide and for street sweeping shall be considered **incidental** to and included in the various bid items.

Payment will be made for the following bid item(s):

“HMA for Pavement Repair Cl. ½””, per ton.

“HMA for Pavement Repair Cl. B””, per ton.

“HMA for Paving Cl. B””, per ton.

The contract bid price above shall be full compensation for all costs for all labor, material, tools, incidental Work, and equipment necessary to satisfactorily complete the Work as defined in the Standard Specifications and these Special Provisions.

5-04.5(1) Asphalt Cost Price Adjustment

(Special Provision)

New Section

The Contracting Agency will make an Asphalt Cost Price Adjustment, either a credit or a payment, for qualifying changes in the reference cost of asphalt binder. The adjustment will be applied to partial payments made according to Section 1-09.9 for the following bid items when they are included in the proposal:

“HMA for Pavement Repair Cl. ____”

“HMA for Paving Cl. ____”

The adjustment is not a guarantee of full compensation for changes in the cost of asphalt binder. The Contracting Agency does not guarantee that asphalt binder will be available at the reference cost.

The Contracting Agency will utilize the asphalt binder reference cost from the WSDOT website at:

<http://www.wsdot.wa.gov/Business/Construction/EscalationClauses.htm>

The base cost established for this contract is the reference cost posted on the WSDOT website with an effective date immediately preceding the bid opening date.

Adjustments will be based on the most current reference cost for Western Washington as posted on the WSDOT website. For Work completed after all authorized working days are used, the adjustment will be based on the posted reference cost during which contract time was exhausted. The adjustment will be calculated as follows:

No adjustment will be made if the reference cost is within 5% of the base cost.

If the reference cost is greater than or equal to 105% of the base cost, then

Adjustment = (Current Reference Cost – (1.05 x Base Cost)) x (Q x 0.056).

If the reference cost is less than or equal to 95% of the base cost, then

Adjustment = (Current Reference Cost – (0.95 x Base Cost)) x (Q x 0.056).

Where Q = total tons of all classes of HMA paid in the current month's progress payment.

"Asphalt Cost Price Adjustment", by calculation.

"Asphalt Cost Price Adjustment" will be calculated and paid for as described in this section. For the purpose of providing a common proposal for all bidders, the Contracting Agency has entered an amount in the proposal to become a part of the total bid by the Contractor.

DIVISION 7
DRAINAGE STRUCTURES, STORM SEWERS, SANITARY SEWERS, WATER MAINS, AND CONDUITS

7-00 GENERAL MATTERS

(Special Provision)

New Section

7-00.1 General

The Contractor is advised that the locations of various existing utilities including but not limited to: gas, water, telephone, cable service lines, and other obstructions are not necessarily shown on the Plans. Locations, if shown, are approximate and have been obtained from records and cannot be guaranteed accurate. The Contractor shall diligently check for interferences with existing utilities ahead of his or her Work including exploration in advance of excavation. It will be the Contractor's responsibility to coordinate with franchise utilities so that services are maintained per City standards. This will include coordination and making necessary arrangements with service providers for the reconnection or relocation of service lines away from the proposed storm drainage system.

The Contractor is further alerted to the provisions of RCW 19.122 and his or her responsibilities by performing excavation required by the Contractor Documents and Standard Specifications.

7-05 MANHOLES, INLETS, CATCH BASINS, AND DRYWELLS

7-05.1 Description

(Special Provision)

Supplement

This Work consists of furnishing and installing new catch basin frames and grates and installing new manhole rings and covers.

7-05.2 Materials

(Special Provision)

Supplement

All new catch basin frames and grates shall have vaned or herringbone grates or solid locking lids as designated on the plans. All frames and grates shall be the 18" x 24" size.

Concrete adjustment rings shall conform to the ASTM C-32, Grade MA.

7-05.3 Construction Requirements

(Special Provision)

Supplement

Furnish and Install New Catch Basin Frame and Grate or Solid Lid

Where indicated on the Plans, the Contractor shall remove existing frames and grates and install new ductile iron frames and grates or solid lids on the existing catch basin and adjust the frame and grate to new finished grade as necessary. The removed catch basin frame and grates shall become the property of the City and shall be delivered to the City Maintenance Shop.

Install New Manhole Ring and Cover

The Contractor shall remove existing rings and covers and install new ductile iron rings and covers on the existing manholes and adjust the rings and covers to new finished grades, as necessary, in locations to be designated by the Engineer. The new rings and covers will be furnished to the Contractor by the City and will be available for pickup at the City Maintenance Shop. The removed rings and covers shall become the property of the City and shall be delivered to the City Maintenance Shop. "SEWER" covers shall be installed on sanitary sewer manholes and "DRAIN" covers on type 2 catch basins.

7-05.3(1) Adjusting Manholes and Catch Basins to Grade

(Special Provision)

Supplement

Jackhammer around the casting with a maximum clearance of twelve (12) inches. Following the removal of the asphalt and concrete around the structure, clean the castings and the inside of the structure, and remove all tack coat, asphalt, paper, and other debris. Remove failed, crushed, or defective brickwork down to solid full-width bricks. Where shown on the plans, existing frame installed inverted shall be reversed and reinstalled in the correct orientation. Provide and install new concrete brick or concrete riser sections, conforming to Section 9-12.2, to bring the frame to the proper finished grade and cross slope of the finished asphalt pavement. Set the casting on full-width bricks or risers, using shims to make final grade adjustment. Completely grout the inside and outside to fill any voids between riser bricks. Remove any wooden shims prior to final grout Work. Place "HMA for Paving Cl. ____" around the casting to match into the adjacent finished pavement. Seal all asphalt joints. Compaction shall be done using a pneumatic or hydraulic 'pogo stick'.

Any utility structure lid, casting, cover, grate, or asphalt patch in the traveled way whose finished grade is higher or lower than the adjacent finished asphalt pavement, as measured by a ten-foot straight edge, by ¼-inch or more shall be readjusted by the Contractor at his or her own expense.

Utility castings shown on the drawings or designated by the Engineer for replacement shall be installed and adjusted to final grade in the above described manner.

7-05.4 Measurement

(Special Provision)

Supplement

"Lower Utility for Profile Gridding" will be measured per each utility casting lowered and shall include catch basins, manhole ring and covers, valve boxes, monuments, and the like.

"Furnish and Install New ____ Catch Basin Frame and ____" will be measured per each.

"Install New Manhole Ring and Cover" will be measured per each.

7-05.5 Payment

(Special Provision)

Supplement

Payment will be made once for each casting, upon adjustment to final grade.

Included in the cost for new drainage structures shall be furnishing, installing, and adjusting to final grade the frame and grate of the type specified.

Removal and cleaning of pavement and tack from lids and grates shall be **incidental** to the bid items.

Payment will be made for the following bid item(s):

“Lower Utility for Profile Grinding”, per each.

“Furnish and Install New ___ Catch Basin Frame and ___”, per each.

“Install New Manhole Ring and Cover”, per each.

The contract bid price above, including all incidental Work, shall be full compensation for all labor, material, tools, and equipment necessary to satisfactorily complete the Work as defined in the Standard Specifications and these Special Provisions.

The bid items “Furnish and Install New ___ Catch Basin Frame and ___” shall include furnishing, installing, and adjusting to finished grade.

The bid item “Install New Manhole Ring and Cover” shall include installing and adjusting to finished grade.

7-07 CLEANING EXISTING DRAINAGE STRUCTURES

7-07.5 Payment

(Special Provision)

Supplement

Cleaning of storm drainage and sanitary sewer structures at project completion shall be measured and paid for by force account, per section 1-09.6, under the bid item “Erosion/Water Pollution Control”.

7-12 VALVES FOR WATER MAINS

7-12.1 Description

(Special Provision)

Supplement

Adjusting Valves to Grade

Valve boxes, including existing water and gas valve boxes, shall be adjusted to grade per the requirements of Adjusting Manholes and Catch Basins to Grade per 7-05.3(1) herein.

7-12.2 Materials

(Special Provision)

Supplement

New valve boxes will be furnished as needed to the Contractor by the City and will be available for pickup at the City Maintenance Shop.

7-12.4 Measurement

(Special Provision)

Supplement

“Adjust Valve Box” will be measured per each, regardless of whether new parts are used or not.

7-12.5 Payment

(Special Provision)

Supplement

“Adjust Valve Box”, per each.

The unit price per each for “Adjust Valve Box” shall be full compensation for furnishing all materials, installing, and adjusting the valve box to grade in accordance with the plans and details.

7-15 SERVICE CONNECTIONS

7-15.1 General

(Special Provision)

Supplement

This Work consists of adjusting water meter boxes to finished grade and replacing existing water meter boxes with new steel meter boxes furnished by the City as directed by the Engineer.

7-15.3 Construction Requirements

(Special Provision)

Supplement

Set meter boxes on firm compacted gravel backfill and adjust to finished grade. In paved areas set meter box on concrete blocks that bear on compacted gravel.

7-15.4 Measurement

(Special Provision)

Supplement

“Adjust Water Meter Box” will be measured per each.

7-15.5 Payment

(Special Provision)

Supplement

“Adjust Water Meter Box” shall be per each.

The unit price for “Adjust Water Meter Box” and shall be full compensation for all Work to adjust the existing water meter box to finished grade in accordance with the plans and details.

**DIVISION 8
MISCELLANEOUS CONSTRUCTION**

8-01 EROSION CONTROL AND WATER POLLUTION CONTROL

8-01.1 Description

(Special Provision)

Supplement

The Contractor shall install and maintain all temporary and permanent erosion control measures and Best Management Practices (BMP's) in accordance with the Plans, Standard Specifications, Special Provisions, permit conditions, or as directed by the Engineer prior to clearing, grubbing, or grading or as necessary as clearing and grading progress. Such measures shall include, but are not necessarily limited to:

- Erosion and water pollution control for stockpiled materials
- Straw bale check dams
- Straw mulch, netting, and tackifier
- Temporary construction entrance/exit
- Inlet protection on existing and proposed drainage structures
- Reinforced silt fencing
- Plastic covering
- Temporary HMA curb
- Disposal of sediments and materials
- Maintenance of BMPs including in the event of emergencies and as weather and field conditions dictate; and also including installation of additional BMPs which may become required as field and weather conditions evolve.
- Street sweeping and cleaning
- All materials, tools, and equipment necessary to meet these requirements

All disturbed areas shall be hydroseeded except as are designated for edge restoration or roadside restoration. The seeding may be accomplished by approved hand methods when impractical to perform by hydroseeding. The Contractor shall submit the proposed plan for hand seeding to the Engineer for approval five days prior to any seeding.

Water

The Contractor shall make, at the Contractor's expense, whatever arrangements may be necessary to ensure an adequate supply of water required for erosion control. The Contractor shall also furnish all necessary hose, equipment, attachments, and accessories for the adequate irrigation of planted areas as may be required to complete the Work as specified.

The Contractor is notified double check valve assemblies on meters must be certified **each time** they are hooked up to a hydrant, even if the hydrant has been used before, per Mercer Island requirements.

8-01.3 Construction Requirements

8-01.3(8) Street Cleaning

(Special Provision)

Supplement

The Contractor shall be responsible for controlling dust and mud within the project. All streets used by the Contractor during the execution of the Work under this contract shall be maintained in a clean condition. Any damage caused by dust and/or mud shall be the sole responsibility of the Contractor. In no case shall sediment-laden water be allowed to enter drainage facilities without prior filtration or sedimentation.

The roadway shall be swept daily and as needed. Flushing will not be permitted.

8-01.3(9)D Inlet Protection

(Special Provision)

Supplement

Inlet protection can be in the form of internal devices and shall be installed prior to clearing, grubbing, or earthwork activities. Catch basin inserts shall be installed on all existing and new catch basins that are located within the project.

Catch Basin Inserts

Catch basin inserts shall be installed at all catch basins within project limits and those immediately downstream of the project site that could possibly receive sediment laden runoff from the site. They shall be installed and meet the requirements of the detail in the Plans. Simply placing a piece of geotextile under the catch basin grate is not acceptable.

Catch basin inserts shall be installed, maintained, inspected, and removed per the Standard Specifications and as recommended by the manufacturer. Pre-approved manufactured products include:

- Siltsack by Atlantic Construction Fabrics, Inc., (800) 448-3636
- StreamGuard by Foss Environmental, (800) 909-3677
- Emcom Insert by Emcom NW, (425) 462-1280
- Beaver Dam or Dandy Bag by Dandy Products, Inc., (800) 591-2284
- Envirodrain
- Drain Warden, or
- Approved Equal

8-01.3(16) Removal

(Special Provision)

Supplement

Removing Erosion/Water Pollution Control BMPs

The Contractor shall removal all Temporary Erosion/Water Pollution Control BMPs within twenty (20) days after final slope stabilization, landscape restoration, or after the BMPs are no longer needed. Trapped sediment shall be removed or stabilized on site.

8-01.3(17) Suspension of Work

(Special Provision)

New Section

If at any time during the life of this Contract it becomes necessary, or the Contractor elects to suspend Work due to weather conditions, material delivery schedules, or other constraints, it shall be the Contractor's obligation to meet the following requirements:

- The Contractor shall remain obligated to meet the Temporary Water Pollution / Erosion Control requirements of the Plans during any suspension of Work.
- The Contractor shall remain obligated to meet the Temporary Traffic Control (both vehicular and pedestrian) requirements of the Plans during any suspension of Work.
- The Contractor shall maintain vigilance and maintain a safe project area free of hazards to public safety and shall remedy all hazardous situations immediately.

8-01.4 Measurement

(Special Provision)

Supplement

"Erosion/Water Pollution Control" shall be by force account.

"Inlet Protection" will be measured per each for each initial installation at a drainage structure.

Relocation and/or replacement of damaged protection devices will not be measured.

8-01.5 Payment

(Special Provision)

Supplement

All costs associated with providing water for the Work in this contract shall be **incidental** to other bid items and no additional payment will be made.

Roadway sweeping and cleaning shall be considered **incidental** to other bid items and no additional payment will be made.

Payment will be made for the following bid item(s):

"Erosion/Water Pollution Control", by force account.

"Inlet Protection", per each initial installation at a drainage structure.

No additional compensation shall be made for reuse or relocation of "Inlet Protection".

Sediment removal from and maintenance of erosion control devices will be paid by force account under the item "Erosion/Water Pollution Control". To provide a common proposal for all bidders, the Contracting Agency has entered an amount in the proposal to become part of the Contractor's total bid. Measurement by force account shall be full compensation for all labor, material, tools, and equipment necessary to satisfactorily complete the Work as defined in the Standard Specifications and these Special Provisions.

8-02 ROADSIDE RESTORATION

8-02.1 Description

(Special Provision)

Supplement

The Work shall consist of placing Crushed Surfacing Top Course, Topsoil Type C, and Bark or Wood Chip Mulch, hereinafter referred to as "restoration materials", along finished edges of paved areas.

8-02.2 Materials

(Special Provision)

Supplement

Crushed Surfacing

9-03.9(3)

8-02.3 Construction Requirements

(Special Provision)

Supplement

Remove all construction debris prior to placing restoration materials.

Place restoration materials according to the Plans or as directed by the Engineer.

Crushed Surfacing Top Course shall be compacted in accordance with Section 4-04.3(11).

8-02.3(2)A Chemical Pesticides

(Special Provision)

Supplement

No chemical herbicides will be allowed in any planting areas.

8-02.3(4) Topsoil

(Special Provision)

Supplement

Topsoil shall be placed as directed by the Engineer for property restoration Work.

Topsoil shall meet the requirements of Section 9-14.1(3).

8-02.3(17) Property Restoration

(Special Provision)

New Section

Roadside planting for property restoration shall consist of fine grading adjacent landscaped areas, extra seeding, or sod installation, new plant material, slope restorations, and other landscape restoration Work not currently identified on the Plans, as directed by the Engineer.

The Contractor is specifically reminded that unnecessary damage caused beyond the limits of clearing or construction shall be repaired in like or better condition at the Contractor's sole expense.

8-02.4 Measurement

(Special Provision)

Supplement

“Property Restoration” shall be by force account.

8-02.5 Payment

(Special Provision)

Supplement

“Crushed Surfacing Top Course (or Base Course)”, per ton.

Topsoil Type C and Bark or Wood Chip Mulch shall be paid for under the “Property Restoration” bid item.

“Property Restoration”, by force account.

Measurement by force account for Property Restoration shall be full compensation for all labor, material, tools, and equipment necessary to satisfactorily complete the Work as identified in the Standard Specifications and these Special Provisions. To provide a common proposal for all bidders, the Contracting Agency has entered an amount in the proposal to become part of the Contractor’s total bid.

8-09 RAISED PAVEMENT MARKERS

8-09.4 Measurement

(Special Provision)

Supplement

Markers shall be measured per each for each type of marker furnished and set in place.

8-09.5 Payment

(Special Provision)

Supplement

“Raised Pavement Marker Type 1”, per each.

“Raised Pavement Marker Type 2”, per each.

The unit price per each ““Raised Pavement Marker Type ____”, including all incidental Work, shall be full compensation for all labor, material, tools, and equipment necessary to satisfactorily complete the Work as defined in the Standard Specifications and these Special Provisions.

8-13 MONUMENT CASES

8-13.3 Construction Requirements

(Special Provision)

Supplement

Adjust Monument

Existing monument cases and covers shall be adjusted to grade per the requirements of Section 7-05.3(1).

8-13.4 Measurement

“Adjust Monument Case and Cover” will be measured per each.

8-13.5 Payment

(Special Provision)

Supplement

“Adjust Monument Case and Cover”, per each.

The unit price per each for “Adjust Monument Case and Cover” shall be full compensation for furnishing all materials, tools, and equipment and adjusting the existing monument case to grade in accordance with the plans and details.

“Furnish and Install Monument Case and Cover”, per each.

8-14 CEMENT CONCRETE SIDEWALKS

8-14.1 Description

(Special Provision)

Supplement

The Work shall also include installing detectable warning surface.

8-14.2 Materials

(Special Provision)

Supplement

Detectable warning surface shall be Vanguard Liquid Applied Detectable Warning/TWSI or approved equal.

8-22 PAVEMENT MARKINGS

8-22.2 Materials

(Special Provision)

Supplement

Plastic line shall be Type A – Liquid Hot Applied Thermoplastic. Plastic Sharrow Symbol shall be 125-mil thick with ViziGrip as manufactured by PreMark.

8-22.4 Measurement

(Special Provision)

Supplement

“Paint Line, 4 In. White” shall be measured per linear foot.

“Plastic Line, 12 In. White” shall be measured per linear foot.

“Plastic Sharrow Symbol” shall be measured per each.

“Plastic Speed Bump Symbol” shall be measured per each speed bump. Items to be included in the bid price shall include, but shall not necessarily be limited to: A speed bump chevron marking for each direction of travel, the installation of type 2 white RPM reflectors, and associated lettered markings in accordance with the details shown on the Plans.

8-22.5 Payment

(Special Provision)

Supplement

“Paint Line, 4 In. White”, per linear foot.

“Plastic Line, 12 In. White”, per linear foot.

Payment for 12” Stop Bar will be paid for as one pass of Plastic Line, 12-Inch White.

“Plastic 25 MPH Symbol”, per each.

“Plastic Sharrow Symbol”, per each.

The unit price per linear foot “Paint Line, 4 In. White”, “Plastic Line, 12 In. White”, including all incidental Work, shall be full compensation for all labor, material, tools, and equipment necessary to satisfactorily complete the Work as defined in the Standard Specifications and these Special Provisions.

8-23 TEMPORARY PAVEMENT MARKINGS

8-23.5 Payment

(Special Provision)

Supplement

All costs associated with furnishing, installing, and removing Temporary Pavement Markings shall be considered **incidental** to other bid items in the project. Flagging operations required during installation and removal of the temporary markings will be paid under the bid item “Traffic Control Labor”.

8-26 EDGE RESTORATION

(Special Provision)

New Section

8-26.1 Description

The Work shall consist of placing Crushed Surfacing Top Course, Topsoil, or Bark Mulch along the finished edges of paved areas.

8-26.2 Materials

Crushed Surfacing Top Course shall meet the requirements of Section 9-03.9(3) Crushed Surfacing of the Standard Specifications.

Special Provisions

SP-46

Bark Mulch shall meet the requirements of Section 9-14.4(3) Bark or Wood Chips of the Standard Specifications.

Topsoil shall meet the requirements of Section 9-14.1(3).

8-26.3 Construction Requirements

Edge restoration shall be completed in accordance with the details shown on the Plans. Crushed Surfacing Top Course shall be compacted in accordance with Section 4-04.3(11) Shoulder Ballast of the Standard Specifications.

8-26.5 Payment

Payment will be made for the following bid item(s):

Crushed Surfacing Top Course shall be paid for under the bid item "Crushed Surfacing Top Course (or Base Course)".

Bark Mulch and Topsoil shall be paid for under the force account bid item "Property Restoration".

**DIVISION 9
MATERIALS**

9-03 AGGREGATES

9-03.8 Aggregates for Hot Mix Asphalt

9-03.8(6) HMA Proportions of Material

(Special Provision)

Supplement

The table included in this section is supplemented with the following:

Grading Requirements	
Sieve Size	Class A and B
1-1/4" Square	--
1" Square	--
3/4" Square	100
5/8" Square	--
1/2" Square	90-100
3/8" Square	75-90
US No. 4	46-66
US No. 8	--
UN No. 10	30-42
US No. 40	11-24
US No. 200	3.0-7.0

END OF SPECIAL PROVISIONS

**APPENDIX A:
PREVAILING WAGE RATES**

State of Washington
Department of Labor & Industries
Prevailing Wage Section - Telephone 360-902-5335
PO Box 44540, Olympia, WA 98504-4540

Washington State Prevailing Wage

The PREVAILING WAGES listed here include both the hourly wage rate and the hourly rate of fringe benefits. On public works projects, worker's wage and benefit rates must add to not less than this total. A brief description of overtime calculation requirements are provided on the Benefit Code Key.

Journey Level Prevailing Wage Rates for the Effective Date: 4/19/2023

<u>County</u>	<u>Trade</u>	<u>Job Classification</u>	<u>Wage</u>	<u>Holiday</u>	<u>Overtime</u>	<u>Note</u>	<u>*Risk Class</u>
King	Flaggers	Journey Level	\$48.14	15J	4V	8Y	View
King	Laborers	Air, Gas Or Electric Vibrating Screed	\$56.80	15J	4V	8Y	View
King	Laborers	Airtrac Drill Operator	\$58.56	15J	4V	8Y	View
King	Laborers	Ballast Regular Machine	\$56.80	15J	4V	8Y	View
King	Laborers	Batch Weighman	\$48.14	15J	4V	8Y	View
King	Laborers	Brick Pavers	\$56.80	15J	4V	8Y	View
King	Laborers	Brush Cutter	\$56.80	15J	4V	8Y	View
King	Laborers	Brush Hog Feeder	\$56.80	15J	4V	8Y	View
King	Laborers	Burner	\$56.80	15J	4V	8Y	View
King	Laborers	Caisson Worker	\$58.56	15J	4V	8Y	View
King	Laborers	Carpenter Tender	\$56.80	15J	4V	8Y	View
King	Laborers	Cement Dumper-paving	\$57.84	15J	4V	8Y	View
King	Laborers	Cement Finisher Tender	\$56.80	15J	4V	8Y	View
King	Laborers	Change House Or Dry Shack	\$56.80	15J	4V	8Y	View
King	Laborers	Chipping Gun (30 Lbs. And Over)	\$57.84	15J	4V	8Y	View
King	Laborers	Chipping Gun (Under 30 Lbs.)	\$56.80	15J	4V	8Y	View
King	Laborers	Choker Setter	\$56.80	15J	4V	8Y	View
King	Laborers	Chuck Tender	\$56.80	15J	4V	8Y	View
King	Laborers	Clary Power Spreader	\$57.84	15J	4V	8Y	View
King	Laborers	Clean-up Laborer	\$56.80	15J	4V	8Y	View
King	Laborers	Concrete Dumper/Chute Operator	\$57.84	15J	4V	8Y	View
King	Laborers	Concrete Form Stripper	\$56.80	15J	4V	8Y	View
King	Laborers	Concrete Placement Crew	\$57.84	15J	4V	8Y	View
King	Laborers	Concrete Saw Operator/Core Driller	\$57.84	15J	4V	8Y	View
King	Laborers	Crusher Feeder	\$48.14	15J	4V	8Y	View
King	Laborers	Curing Laborer	\$56.80	15J	4V	8Y	View
King	Laborers	Demolition: Wrecking & Moving (Incl. Charred Material)	\$56.80	15J	4V	8Y	View
King	Laborers	Ditch Digger	\$56.80	15J	4V	8Y	View
King	Laborers	Diver	\$58.56	15J	4V	8Y	View
King	Laborers	Drill Operator (Hydraulic, Diamond)	\$57.84	15J	4V	8Y	View
King	Laborers	Dry Stack Walls	\$56.80	15J	4V	8Y	View
King	Laborers	Dump Person	\$56.80	15J	4V	8Y	View
King	Laborers	Epoxy Technician	\$56.80	15J	4V	8Y	View
King	Laborers	Erosion Control Worker	\$56.80	15J	4V	8Y	View
King	Laborers	Faller & Bucker Chain Saw	\$57.84	15J	4V	8Y	View

King	Laborers	Fine Graders	\$56.80	15J	4V	8Y	View
King	Laborers	Firewatch	\$48.14	15J	4V	8Y	View
King	Laborers	Form Setter	\$57.84	15J	4V	8Y	View
King	Laborers	Gabian Basket Builders	\$56.80	15J	4V	8Y	View
King	Laborers	General Laborer	\$56.80	15J	4V	8Y	View
King	Laborers	Grade Checker & Transit Person	\$59.85	15J	4V	8Y	View
King	Laborers	Grinders	\$56.80	15J	4V	8Y	View
King	Laborers	Grout Machine Tender	\$56.80	15J	4V	8Y	View
King	Laborers	Groutmen (Pressure) Including Post Tension Beams	\$57.84	15J	4V	8Y	View
King	Laborers	Guardrail Erector	\$56.80	15J	4V	8Y	View
King	Laborers	Hazardous Waste Worker (Level A)	\$58.56	15J	4V	8Y	View
King	Laborers	Hazardous Waste Worker (Level B)	\$57.84	15J	4V	8Y	View
King	Laborers	Hazardous Waste Worker (Level C)	\$56.80	15J	4V	8Y	View
King	Laborers	High Scaler	\$58.56	15J	4V	8Y	View
King	Laborers	Jackhammer	\$57.84	15J	4V	8Y	View
King	Laborers	Laserbeam Operator	\$57.84	15J	4V	8Y	View
King	Laborers	Maintenance Person	\$56.80	15J	4V	8Y	View
King	Laborers	Manhole Builder-Mudman	\$57.84	15J	4V	8Y	View
King	Laborers	Material Yard Person	\$56.80	15J	4V	8Y	View
King	Laborers	Mold Abatement Worker	\$56.80	15J	4V	8Y	View
King	Laborers	Motorman-Dinky Locomotive	\$59.95	15J	4V	8Y	View
King	Laborers	nozzleman (concrete pump, green cutter when using combination of high pressure air & water on concrete & rock, sandblast, gunite, shotcrete, water blaster, vacuum blaster)	\$59.85	15J	4V	8Y	View
King	Laborers	Pavement Breaker	\$57.84	15J	4V	8Y	View
King	Laborers	Pilot Car	\$48.14	15J	4V	8Y	View
King	Laborers	Pipe Layer (Lead)	\$59.85	15J	4V	8Y	View
King	Laborers	Pipe Layer/Tailor	\$57.84	15J	4V	8Y	View
King	Laborers	Pipe Pot Tender	\$57.84	15J	4V	8Y	View
King	Laborers	Pipe Reliner	\$57.84	15J	4V	8Y	View
King	Laborers	Pipe Wrapper	\$57.84	15J	4V	8Y	View
King	Laborers	Pot Tender	\$56.80	15J	4V	8Y	View
King	Laborers	Powderman	\$58.56	15J	4V	8Y	View
King	Laborers	Powderman's Helper	\$56.80	15J	4V	8Y	View
King	Laborers	Power Jacks	\$57.84	15J	4V	8Y	View
King	Laborers	Railroad Spike Puller - Power	\$57.84	15J	4V	8Y	View
King	Laborers	Raker - Asphalt	\$59.85	15J	4V	8Y	View
King	Laborers	Re-timberman	\$58.56	15J	4V	8Y	View
King	Laborers	Remote Equipment Operator	\$57.84	15J	4V	8Y	View
King	Laborers	Rigger/Signal Person	\$57.84	15J	4V	8Y	View
King	Laborers	Rip Rap Person	\$56.80	15J	4V	8Y	View
King	Laborers	Rivet Buster	\$57.84	15J	4V	8Y	View
King	Laborers	Rodder	\$57.84	15J	4V	8Y	View
King	Laborers	Scaffold Erector	\$56.80	15J	4V	8Y	View
King	Laborers	Scale Person	\$56.80	15J	4V	8Y	View
King	Laborers	Sloper (Over 20")	\$57.84	15J	4V	8Y	View
King	Laborers	Sloper Sprayer	\$56.80	15J	4V	8Y	View
King	Laborers	Spreader (Concrete)	\$57.84	15J	4V	8Y	View
King	Laborers	Stake Hopper	\$56.80	15J	4V	8Y	View

King	Laborers	Stock Piler	\$56.80	15J	4V	8Y	View
King	Laborers	Swinging Stage/Boatswain Chair	\$48.14	15J	4V	8Y	View
King	Laborers	Tamper & Similar Electric, Air & Gas Operated Tools	\$57.84	15J	4V	8Y	View
King	Laborers	Tamper (Multiple & Self-propelled)	\$57.84	15J	4V	8Y	View
King	Laborers	Timber Person - Sewer (Lagger, Shorer & Cribber)	\$57.84	15J	4V	8Y	View
King	Laborers	Toolroom Person (at Jobsite)	\$56.80	15J	4V	8Y	View
King	Laborers	Topper	\$56.80	15J	4V	8Y	View
King	Laborers	Track Laborer	\$56.80	15J	4V	8Y	View
King	Laborers	Track Liner (Power)	\$57.84	15J	4V	8Y	View
King	Laborers	Traffic Control Laborer	\$51.48	15J	4V	9C	View
King	Laborers	Traffic Control Supervisor	\$54.55	15J	4V	9C	View
King	Laborers	Truck Spotter	\$56.80	15J	4V	8Y	View
King	Laborers	Tugger Operator	\$57.84	15J	4V	8Y	View
King	Laborers	Tunnel Work-Compressed Air Worker 0-30 psi	\$158.87	15J	4V	9B	View
King	Laborers	Tunnel Work-Compressed Air Worker 30.01-44.00 psi	\$163.90	15J	4V	9B	View
King	Laborers	Tunnel Work-Compressed Air Worker 44.01-54.00 psi	\$167.58	15J	4V	9B	View
King	Laborers	Tunnel Work-Compressed Air Worker 54.01-60.00 psi	\$173.28	15J	4V	9B	View
King	Laborers	Tunnel Work-Compressed Air Worker 60.01-64.00 psi	\$175.40	15J	4V	9B	View
King	Laborers	Tunnel Work-Compressed Air Worker 64.01-68.00 psi	\$180.50	15J	4V	9B	View
King	Laborers	Tunnel Work-Compressed Air Worker 68.01-70.00 psi	\$182.40	15J	4V	9B	View
King	Laborers	Tunnel Work-Compressed Air Worker 70.01-72.00 psi	\$184.40	15J	4V	9B	View
King	Laborers	Tunnel Work-Compressed Air Worker 72.01-74.00 psi	\$186.40	15J	4V	9B	View
King	Laborers	Tunnel Work-Guage and Lock Tender	\$59.95	15J	4V	8Y	View
King	Laborers	Tunnel Work-Miner	\$59.95	15J	4V	8Y	View
King	Laborers	Vibrator	\$57.84	15J	4V	8Y	View
King	Laborers	Vinyl Seamer	\$56.80	15J	4V	8Y	View
King	Laborers	Watchman	\$43.76	15J	4V	8Y	View
King	Laborers	Welder	\$57.84	15J	4V	8Y	View
King	Laborers	Well Point Laborer	\$57.84	15J	4V	8Y	View
King	Laborers	Window Washer/Cleaner	\$43.76	15J	4V	8Y	View
King	Landscape Construction	Landscape Construction/Landscaping Or Planting Laborers	\$43.76	15J	4V	8Y	View
King	Landscape Construction	Landscape Operator	\$78.80	15J	11G	8X	View
King	Power Equipment Operators	Asphalt Plant Operators	\$80.12	15J	11G	8X	View
King	Power Equipment Operators	Assistant Engineer	\$75.35	15J	11G	8X	View
King	Power Equipment Operators	Barrier Machine (zipper)	\$79.41	15J	11G	8X	View
King	Power Equipment Operators	Batch Plant Operator: concrete	\$79.41	15J	11G	8X	View
King	Power Equipment Operators	Boat Operator	\$80.33	7A	11H	8X	View
King	Power Equipment Operators	Bobcat	\$75.35	15J	11G	8X	View
King	Power Equipment Operators	Brokk - Remote Demolition Equipment	\$75.35	15J	11G	8X	View
King	Power Equipment Operators	Brooms	\$75.35	15J	11G	8X	View
King	Power Equipment Operators	Bump Cutter	\$79.41	15J	11G	8X	View

King	Power Equipment Operators	Cableways	\$80.12	15J	11G	8X	View
King	Power Equipment Operators	Chipper	\$79.41	15J	11G	8X	View
King	Power Equipment Operators	Compressor	\$75.35	15J	11G	8X	View
King	Power Equipment Operators	Concrete Finish Machine - Laser Screed	\$75.35	15J	11G	8X	View
King	Power Equipment Operators	Concrete Pump - Mounted Or Trailer High Pressure Line Pump, Pump High Pressure	\$78.80	15J	11G	8X	View
King	Power Equipment Operators	Concrete Pump: Truck Mount With Boom Attachment Over 42 M	\$80.12	15J	11G	8X	View
King	Power Equipment Operators	Concrete Pump: Truck Mount With Boom Attachment Up To 42m	\$79.41	15J	11G	8X	View
King	Power Equipment Operators	Conveyors	\$78.80	15J	11G	8X	View
King	Power Equipment Operators	Cranes Friction: 200 tons and over	\$82.76	7A	11H	8X	View
King	Power Equipment Operators	Cranes, A-frame: 10 tons and under	\$75.55	7A	11H	8X	View
King	Power Equipment Operators	Cranes: 100 tons through 199 tons, or 150' of boom (including jib with attachments)	\$81.12	7A	11H	8X	View
King	Power Equipment Operators	Cranes: 20 tons through 44 tons with attachments	\$79.62	7A	11H	8X	View
King	Power Equipment Operators	Cranes: 200 tons- 299 tons, or 250' of boom including jib with attachments	\$81.97	7A	11H	8X	View
King	Power Equipment Operators	Cranes: 300 tons and over or 300' of boom including jib with attachments	\$82.76	7A	11H	8X	View
King	Power Equipment Operators	Cranes: 45 tons through 99 tons, under 150' of boom(including jib with attachments)	\$80.33	7A	11H	8X	View
King	Power Equipment Operators	Cranes: Friction cranes through 199 tons	\$81.97	7A	11H	8X	View
King	Power Equipment Operators	Cranes: through 19 tons with attachments, a-frame over 10 tons	\$79.00	7A	11H	8X	View
King	Power Equipment Operators	Crusher	\$79.41	15J	11G	8X	View
King	Power Equipment Operators	Deck Engineer/Deck Winches (power)	\$79.41	15J	11G	8X	View
King	Power Equipment Operators	Derricks, On Building Work	\$80.12	15J	11G	8X	View
King	Power Equipment Operators	Dozers D-9 & Under	\$78.80	15J	11G	8X	View
King	Power Equipment Operators	Drill Oilers: Auger Type, Truck Or Crane Mount	\$78.80	15J	11G	8X	View
King	Power Equipment Operators	Drilling Machine	\$80.92	15J	11G	8X	View
King	Power Equipment Operators	Elevator and man-lift: permanent and shaft type	\$75.35	15J	11G	8X	View
King	Power Equipment Operators	Finishing Machine, Bidwell And Gamaco & Similar Equipment	\$79.41	15J	11G	8X	View
King	Power Equipment Operators	Forklift: 3000 lbs and over with attachments	\$78.80	15J	11G	8X	View
King	Power Equipment Operators	Forklifts: under 3000 lbs. with attachments	\$75.35	15J	11G	8X	View
King	Power Equipment Operators	Grade Engineer: Using Blue Prints, Cut Sheets, Etc	\$79.41	15J	11G	8X	View
King	Power Equipment Operators	Gradechecker/Stakeman	\$75.35	15J	11G	8X	View
King	Power Equipment Operators	Guardrail Punch	\$79.41	15J	11G	8X	View
King	Power Equipment Operators	Hard Tail End Dump Articulating Off-Road Equipment 45 Yards. & Over	\$80.12	15J	11G	8X	View
King	Power Equipment Operators	Hard Tail End Dump Articulating Off-road Equipment Under 45 Yards	\$79.41	15J	11G	8X	View

King	Power Equipment Operators	Horizontal/Directional Drill Locator	\$78.80	15J	11G	8X	View
King	Power Equipment Operators	Horizontal/Directional Drill Operator	\$79.41	15J	11G	8X	View
King	Power Equipment Operators	Hydralifts/Boom Trucks Over 10 Tons	\$79.00	7A	11H	8X	View
King	Power Equipment Operators	Hydralifts/boom trucks: 10 tons and under	\$75.55	7A	11H	8X	View
King	Power Equipment Operators	Leverman	\$81.75	15J	11G	8X	View
King	Power Equipment Operators	Loader, Overhead, 6 Yards. But Not Including 8 Yards	\$80.12	15J	11G	8X	View
King	Power Equipment Operators	Loaders, Overhead Under 6 Yards	\$79.41	15J	11G	8X	View
King	Power Equipment Operators	Loaders, Plant Feed	\$79.41	15J	11G	8X	View
King	Power Equipment Operators	Loaders: Elevating Type Belt	\$78.80	15J	11G	8X	View
King	Power Equipment Operators	Locomotives, All	\$79.41	15J	11G	8X	View
King	Power Equipment Operators	Material Transfer Device	\$79.41	15J	11G	8X	View
King	Power Equipment Operators	Mechanics: All (Leadmen - \$0.50 per hour over mechanic)	\$80.92	15J	11G	8X	View
King	Power Equipment Operators	Motor Patrol Graders	\$80.12	15J	11G	8X	View
King	Power Equipment Operators	Mucking Machine, Mole, Tunnel Drill, Boring, Road Header And/or Shield	\$80.12	15J	11G	8X	View
King	Power Equipment Operators	Oil Distributors, Blower Distribution & Mulch Seeding Operator	\$75.35	15J	11G	8X	View
King	Power Equipment Operators	Outside Hoists (Elevators and Manlifts), Air Tuggers, Strato	\$78.80	15J	11G	8X	View
King	Power Equipment Operators	Overhead, bridge type Crane: 20 tons through 44 tons	\$79.62	7A	11H	8X	View
King	Power Equipment Operators	Overhead, bridge type: 100 tons and over	\$81.12	7A	11H	8X	View
King	Power Equipment Operators	Overhead, bridge type: 45 tons through 99 tons	\$80.33	7A	11H	8X	View
King	Power Equipment Operators	Pavement Breaker	\$75.35	15J	11G	8X	View
King	Power Equipment Operators	Pile Driver (other Than Crane Mount)	\$79.41	15J	11G	8X	View
King	Power Equipment Operators	Plant Oiler - Asphalt, Crusher	\$78.80	15J	11G	8X	View
King	Power Equipment Operators	Posthole Digger, Mechanical	\$75.35	15J	11G	8X	View
King	Power Equipment Operators	Power Plant	\$75.35	15J	11G	8X	View
King	Power Equipment Operators	Pumps - Water	\$75.35	15J	11G	8X	View
King	Power Equipment Operators	Quad 9, Hd 41, D10 And Over	\$80.12	15J	11G	8X	View
King	Power Equipment Operators	Quick Tower: no cab, under 100 feet in height base to boom	\$79.41	15J	11G	8X	View
King	Power Equipment Operators	Remote Control Operator On Rubber Tired Earth Moving Equipment	\$80.12	15J	11G	8X	View
King	Power Equipment Operators	Rigger and Bellman	\$75.55	7A	11H	8X	View
King	Power Equipment Operators	Rigger/Signal Person, Bellman(Certified)	\$79.00	7A	11H	8X	View
King	Power Equipment Operators	Rollagon	\$80.12	15J	11G	8X	View
King	Power Equipment Operators	Roller, Other Than Plant Mix	\$75.35	15J	11G	8X	View
King	Power Equipment Operators	Roller, Plant Mix Or Multi-lift Materials	\$78.80	15J	11G	8X	View
King	Power Equipment Operators	Roto-mill, Roto-grinder	\$79.41	15J	11G	8X	View
King	Power Equipment Operators	Saws - Concrete	\$78.80	15J	11G	8X	View
King	Power Equipment Operators	Scraper, Self Propelled Under 45 Yards	\$79.41	15J	11G	8X	View
King	Power Equipment Operators	Scrapers - Concrete & Carry All	\$78.80	15J	11G	8X	View

King	Power Equipment Operators	Scrapers, Self-propelled: 45 Yards And Over	\$80.12	15J	11G	8X	View
King	Power Equipment Operators	Service Engineers: Equipment	\$78.80	15J	11G	8X	View
King	Power Equipment Operators	Shotcrete/Gunite Equipment	\$75.35	15J	11G	8X	View
King	Power Equipment Operators	Shovel, Excavator, Backhoe, Tractors Under 15 Metric Tons	\$78.80	15J	11G	8X	View
King	Power Equipment Operators	Shovel, Excavator, Backhoe: Over 30 Metric Tons To 50 Metric Tons	\$80.12	15J	11G	8X	View
King	Power Equipment Operators	Shovel, Excavator, Backhoes, Tractors: 15 To 30 Metric Tons	\$79.41	15J	11G	8X	View
King	Power Equipment Operators	Shovel, Excavator, Backhoes: Over 50 Metric Tons To 90 Metric Tons	\$80.92	15J	11G	8X	View
King	Power Equipment Operators	Shovel, Excavator, Backhoes: Over 90 Metric Tons	\$81.75	15J	11G	8X	View
King	Power Equipment Operators	Slipform Pavers	\$80.12	15J	11G	8X	View
King	Power Equipment Operators	Spreader, Toppers & Screedman	\$80.12	15J	11G	8X	View
King	Power Equipment Operators	Subgrader Trimmer	\$79.41	15J	11G	8X	View
King	Power Equipment Operators	Tower Bucket Elevators	\$78.80	15J	11G	8X	View
King	Power Equipment Operators	Tower Crane: over 175' through 250' in height, base to boom	\$81.97	7A	11H	8X	View
King	Power Equipment Operators	Tower crane: up to 175' in height base to boom	\$81.12	7A	11H	8X	View
King	Power Equipment Operators	Tower Cranes: over 250' in height from base to boom	\$82.76	7A	11H	8X	View
King	Power Equipment Operators	Transporters, All Track Or Truck Type	\$80.12	15J	11G	8X	View
King	Power Equipment Operators	Trenching Machines	\$78.80	15J	11G	8X	View
King	Power Equipment Operators	Truck Crane Oiler/Driver: 100 tons and over	\$79.62	7A	11H	8X	View
King	Power Equipment Operators	Truck crane oiler/driver: under 100 tons	\$79.00	7A	11H	8X	View
King	Power Equipment Operators	Truck Mount Portable Conveyor	\$79.41	15J	11G	8X	View
King	Power Equipment Operators	Vac Truck (Vactor Guzzler, Hydro Excavator)	\$79.41	15J	11G	8X	View
King	Power Equipment Operators	Welder	\$80.12	15J	11G	8X	View
King	Power Equipment Operators	Wheel Tractors, Farmall Type	\$75.35	15J	11G	8X	View
King	Power Equipment Operators	Yo Yo Pay Dozer	\$79.41	15J	11G	8X	View
King	Street And Parking Lot Sweeper Workers	Journey Level	\$19.09		1		View
King	Traffic Control Stripers	Journey Level	\$51.90	7A	1K		View
King	Truck Drivers	Asphalt Mix Over 16 Yards	\$72.45	15J	11M	8L	View
King	Truck Drivers	Asphalt Mix To 16 Yards	\$71.61	15J	11M	8L	View
King	Truck Drivers	Dump Truck	\$71.61	15J	11M	8L	View
King	Truck Drivers	Dump Truck & Trailer	\$72.45	15J	11M	8L	View
King	Truck Drivers	Other Trucks	\$72.45	15J	11M	8L	View

**Washington State Department of Labor and Industries
Policy Statement
(Regarding the Production of "Standard" or "Non-standard" Items)**

Below is the department's (State L&I's) list of criteria to be used in determining whether a prefabricated item is "standard" or "non-standard". For items not appearing on WSDOT's predetermined list, these criteria shall be used by the Contractor (and the Contractor's subcontractors, agents to subcontractors, suppliers, manufacturers, and fabricators) to determine coverage under RCW 39.12. The production, in the State of Washington, of non-standard items is covered by RCW 39.12, and the production of standard items is not. The production of any item outside the State of Washington is not covered by RCW 39.12.

1. Is the item fabricated for a public works project? If not, it is not subject to RCW 39.12. If it is, go to question 2.
2. Is the item fabricated on the public works jobsite? If it is, the work is covered under RCW 39.12. If not, go to question 3.
3. Is the item fabricated in an assembly/fabrication plant set up for, and dedicated primarily to, the public works project? If it is, the work is covered by RCW 39.12. If not, go to question 4.
4. Does the item require any assembly, cutting, modification or other fabrication by the supplier? If not, the work is not covered by RCW 39.12. If yes, go to question 5.
5. Is the prefabricated item intended for the public works project typically an inventory item which could reasonably be sold on the general market? If not, the work is covered by RCW 39.12. If yes, go to question 6.
6. Does the specific prefabricated item, generally defined as standard, have any unusual characteristics such as shape, type of material, strength requirements, finish, etc? If yes, the work is covered under RCW 39.12.

Any firm with questions regarding the policy, WSDOT's Predetermined List, or for determinations of covered and non-covered workers shall be directed to State L&I at (360) 902-5330.

**WSDOT's
Predetermined List for
Suppliers - Manufactures - Fabricator**

Below is a list of potentially prefabricated items, originally furnished by WSDOT to Washington State Department of Labor and Industries, that may be considered non-standard and therefore covered by the prevailing wage law, RCW 39.12. Items marked with an X in the "YES" column should be considered to be non-standard and therefore covered by RCW 39.12. Items marked with an X in the "NO" column should be considered to be standard and therefore not covered. Of course, exceptions to this general list may occur, and in that case shall be evaluated according to the criteria described in State and L&I's policy statement.

ITEM DESCRIPTION	YES	NO
1. Metal rectangular frames, solid metal covers, herringbone grates, and bi-directional vaned grates for Catch Basin Types 1, 1L, 1P, and 2 and Concrete Inlets. See Std. Plans		X
2. Metal circular frames (rings) and covers, circular grates, and prefabricated ladders for Manhole Types 1, 2, and 3, Drywell Types 1, 2, and 3 and Catch Basin Type 2. See Std. Plans		X
3. Prefabricated steel grate supports and welded grates, metal frames and dual vaned grates, and Type 1, 2, and 3 structural tubing grates for Drop Inlets. See Std. Plans.		X
4. Concrete Pipe - Plain Concrete pipe and reinforced concrete pipe Class 2 to 5 sizes smaller than 60 inch diameter.		X
5. Concrete Pipe - Plain Concrete pipe and reinforced concrete pipe Class 2 to 5 sizes larger than 60 inch diameter.		X
6. Corrugated Steel Pipe - Steel lock seam corrugated pipe for culverts and storm sewers, sizes 30 inch to 120 inches in diameter. May also be treated, 1 thru 5.		X
7. Corrugated Aluminum Pipe - Aluminum lock seam corrugated pipe for culverts and storm sewers, sizes 30 inch to 120 inches in diameter. May also be treated, #5.		X

ITEM DESCRIPTION	YES	NO
8. Anchor Bolts & Nuts - Anchor Bolts and Nuts, for mounting sign structures, luminaries and other items, shall be made from commercial bolt stock. See Contract Plans and Std. Plans for size and material type.		X
9. Aluminum Pedestrian Handrail - Pedestrian handrail conforming to the type and material specifications set forth in the contract plans. Welding of aluminum shall be in accordance with Section 9-28.14(3).	X	
10. Major Structural Steel Fabrication - Fabrication of major steel items such as trusses, beams, girders, etc., for bridges.	X	
11. Minor Structural Steel Fabrication - Fabrication of minor steel Items such as special hangers, brackets, access doors for structures, access ladders for irrigation boxes, bridge expansion joint systems, etc., involving welding, cutting, punching and/or boring of holes. See Contact Plans for item description and shop drawings.	X	
12. Aluminum Bridge Railing Type BP - Metal bridge railing conforming to the type and material specifications set forth in the Contract Plans. Welding of aluminum shall be in accordance with Section 9-28.14(3).		X
13. Concrete Piling--Precast-Prestressed concrete piling for use as 55 and 70 ton concrete piling. Concrete to conform to Section 9-19.1 of Std. Spec..	X	
14. Precast Manhole Types 1, 2, and 3 with cones, adjustment sections and flat top slabs. See Std. Plans.		X
15. Precast Drywell Types 1, 2, and with cones and adjustment Sections. See Std. Plans.		X
16. Precast Catch Basin - Catch Basin type 1, 1L, 1P, and 2 With adjustment sections. See Std. Plans.		X

ITEM DESCRIPTION	YES	NO
17. Precast Concrete Inlet - with adjustment sections, See Std. Plans		X
18. Precast Drop Inlet Type 1 and 2 with metal grate supports. See Std. Plans.		X
19. Precast Grate Inlet Type 2 with extension and top units. See Std. Plans		X
20. Metal frames, vaned grates, and hoods for Combination Inlets. See Std. Plans		X
21. Precast Concrete Utility Vaults - Precast Concrete utility vaults of various sizes. Used for in ground storage of utility facilities and controls. See Contract Plans for size and construction requirements. Shop drawings are to be provided for approval prior to casting		X
22. Vault Risers - For use with Valve Vaults and Utilities X Vaults.		X
23. Valve Vault - For use with underground utilities. See Contract Plans for details.		X
24. Precast Concrete Barrier - Precast Concrete Barrier for use as new barrier or may also be used as Temporary Concrete Barrier. Only new state approved barrier may be used as permanent barrier.		X
25. Reinforced Earth Wall Panels – Reinforced Earth Wall Panels in size and shape as shown in the Plans. Fabrication plant has annual approval for methods and materials to be used. See Shop Drawing. Fabrication at other locations may be approved, after facilities inspection, contact HQ. Lab.	X	
26. Precast Concrete Walls - Precast Concrete Walls - tilt-up wall panel in size and shape as shown in Plans. Fabrication plant has annual approval for methods and materials to be used	X	

ITEM DESCRIPTION	YES	NO
27. Precast Railroad Crossings - Concrete Crossing Structure Slabs.	X	
28. 12, 18 and 26 inch Standard Precast Prestressed Girder – Standard Precast Prestressed Girder for use in structures. Fabricator plant has annual approval of methods and materials to be used. Shop Drawing to be provided for approval prior to casting girders. See Std. Spec. Section 6-02.3(25)A	X	
29. Prestressed Concrete Girder Series 4-14 - Prestressed Concrete Girders for use in structures. Fabricator plant has annual approval of methods and materials to be used. Shop Drawing to be provided for approval prior to casting girders. See Std. Spec. Section 6-02.3(25)A	X	
30. Prestressed Tri-Beam Girder - Prestressed Tri-Beam Girders for use in structures. Fabricator plant has annual approval of methods and materials to be used. Shop Drawing to be provided for approval prior to casting girders. See Std. Spec. Section 6-02.3(25)A	X	
31. Prestressed Precast Hollow-Core Slab – Precast Prestressed Hollow-core slab for use in structures. Fabricator plant has annual approval of methods and materials to be used. Shop Drawing to be provided for approval prior to casting girders. See Std. Spec. Section 6-02.3(25)A.	X	
32. Prestressed-Bulb Tee Girder - Bulb Tee Prestressed Girder for use in structures. Fabricator plant has annual approval of methods and materials to be used. Shop Drawing to be provided for approval prior to casting girders. See Std. Spec. Section 6-02.3(25)A	X	
33. Monument Case and Cover See Std. Plan.		X

ITEM DESCRIPTION	YES	NO
34. Cantilever Sign Structure - Cantilever Sign Structure fabricated from steel tubing meeting AASHTO-M-183. See Std. Plans, and Contract Plans for details. The steel structure shall be galvanized after fabrication in accordance with AASHTO-M-111.	X	
35. Mono-tube Sign Structures - Mono-tube Sign Bridge fabricated to details shown in the Plans. Shop drawings for approval are required prior to fabrication.	X	
36. Steel Sign Bridges - Steel Sign Bridges fabricated from steel tubing meeting AASHTO-M-138 for Aluminum Alloys. See Std. Plans, and Contract Plans for details. The steel structure shall be galvanized after fabrication in accordance with AASHTO-M-111.	X	
37. Steel Sign Post - Fabricated Steel Sign Posts as detailed in Std Plans. Shop drawings for approval are to be provided prior to fabrication		X
38. Light Standard-Prestressed - Spun, prestressed, hollow concrete poles.	X	
39. Light Standards - Lighting Standards for use on highway illumination systems, poles to be fabricated to conform with methods and materials as specified on Std. Plans. See Special Provisions for pre-approved drawings.	X	
40. Traffic Signal Standards - Traffic Signal Standards for use on highway and/or street signal systems. Standards to be fabricated to conform with methods and material as specified on Std. Plans. See Special Provisions for pre-approved drawings	X	
41. Precast Concrete Sloped Mountable Curb (Single and DualFaced) See Std. Plans.		X

ITEM DESCRIPTION	YES	NO
42. Traffic Signs - Prior to approval of a Fabricator of Traffic Signs, the sources of the following materials must be submitted and approved for reflective sheeting, legend material, and aluminum sheeting. NOTE: *** Fabrication inspection required. Only signs tagged "Fabrication Approved" by WSDOT Sign Fabrication Inspector to be installed	X	X
	Custom Message	Std Signing Message
43. Cutting & bending reinforcing steel		X
44. Guardrail components	X	X
	Custom End Sec	Standard Sec
45. Aggregates/Concrete mixes	Covered by WAC 296-127-018	
46. Asphalt	Covered by WAC 296-127-018	
47. Fiber fabrics		X
48. Electrical wiring/components		X
49. treated or untreated timber pile		X
50. Girder pads (elastomeric bearing)	X	
51. Standard Dimension lumber		X
52. Irrigation components		X

ITEM DESCRIPTION	YES	NO
53. Fencing materials		X
54. Guide Posts		X
55. Traffic Buttons		X
56. Epoxy		X
57. Cribbing		X
58. Water distribution materials		X
59. Steel "H" piles		X
60. Steel pipe for concrete pile casings		X
61. Steel pile tips, standard		X
62. Steel pile tips, custom	X	

Prefabricated items specifically produced for public works projects that are prefabricated in a county other than the county wherein the public works project is to be completed, the wage for the offsite prefabrication shall be the applicable prevailing wage for the county in which the actual prefabrication takes place.

It is the manufacturer of the prefabricated product to verify that the correct county wage rates are applied to work they perform.

See RCW [39.12.010](#)

(The definition of "locality" in RCW [39.12.010](#)(2) contains the phrase "wherein the physical work is being performed." The department interprets this phrase to mean the actual work site.

WSDOT's List of State Occupations not applicable to Heavy and Highway Construction Projects

This project is subject to the state hourly minimum rates for wages and fringe benefits in the contract provisions, as provided by the state Department of Labor and Industries.

The following list of occupations, is comprised of those occupations that are not normally used in the construction of heavy and highway projects.

When considering job classifications for use and / or payment when bidding on, or building heavy and highway construction projects for, or administered by WSDOT, these Occupations will be excepted from the included "Washington State Prevailing Wage Rates For Public Work Contracts" documents.

- Building Service Employees
- Electrical Fixture Maintenance Workers
- Electricians - Motor Shop
- Heating Equipment Mechanics
- Industrial Engine and Machine Mechanics
- Industrial Power Vacuum Cleaners
- Inspection, Cleaning, Sealing of Water Systems by Remote Control
- Laborers - Underground Sewer & Water
- Machinists (Hydroelectric Site Work)
- Modular Buildings
- Playground & Park Equipment Installers
- Power Equipment Operators - Underground Sewer & Water
- Residential *** ALL ASSOCIATED RATES ***
- Sign Makers and Installers (Non-Electrical)
- Sign Makers and Installers (Electrical)
- Stage Rigging Mechanics (Non Structural)

The following occupations may be used only as outlined in the preceding text concerning "WSDOT's list for Suppliers - Manufacturers - Fabricators"

- Fabricated Precast Concrete Products
- Metal Fabrication (In Shop)

Definitions for the Scope of Work for prevailing wages may be found at the Washington State Department of Labor and Industries web site and in WAC Chapter 296-127.

**Washington State Department of Labor and Industries
Policy Statements
(Regarding Production and Delivery of Gravel, Concrete, Asphalt, etc.)**

WAC 296-127-018 Agency filings affecting this section

Coverage and exemptions of workers involved in the production and delivery of gravel, concrete, asphalt, or similar materials.

(1) The materials covered under this section include but are not limited to: Sand, gravel, crushed rock, concrete, asphalt, or other similar materials.

(2) All workers, regardless of by whom employed, are subject to the provisions of chapter 39.12 RCW when they perform any or all of the following functions:

(a) They deliver or discharge any of the above-listed materials to a public works project site:

(i) At one or more point(s) directly upon the location where the material will be incorporated into the project; or

(ii) At multiple points at the project; or

(iii) Adjacent to the location and coordinated with the incorporation of those materials.

(b) They wait at or near a public works project site to perform any tasks subject to this section of the rule.

(c) They remove any materials from a public works construction site pursuant to contract requirements or specifications (e.g., excavated materials, materials from demolished structures, clean-up materials, etc.).

(d) They work in a materials production facility (e.g., batch plant, borrow pit, rock quarry, etc.) which is established for a public works project for the specific, but not necessarily exclusive, purpose of supplying materials for the project.

(e) They deliver concrete to a public works site regardless of the method of incorporation.

(f) They assist or participate in the incorporation of any materials into the public works project.

(3) All travel time that relates to the work covered under subsection (2) of this section requires the payment of prevailing wages. Travel time includes time spent waiting to load, loading, transporting, waiting to unload, and delivering materials. Travel time would include all time spent in travel in support of a public works project whether the vehicle is empty or full. For example, travel time spent returning to a supply source to obtain another load of material for use on a public works site or returning to the public works site to obtain another load of excavated material is time spent in travel that is subject to prevailing wage. Travel to a supply source, including travel from a public works site, to obtain materials for use on a private project would not be travel subject to the prevailing wage.

(4) Workers are not subject to the provisions of chapter 39.12 RCW when they deliver materials to a stockpile.

(a) A "stockpile" is defined as materials delivered to a pile located away from the site of incorporation such that the stockpiled materials must be physically moved from the stockpile and transported to another location on the project site in order to be incorporated into the project.

(b) A stockpile does not include any of the functions described in subsection (2)(a) through (f) of this section; nor does a stockpile include materials delivered or distributed to multiple locations upon the project site; nor does a stockpile include materials dumped at the place of incorporation, or adjacent to the location and coordinated with the incorporation.

(5) The applicable prevailing wage rate shall be determined by the locality in which the work is performed. Workers subject to subsection (2)(d) of this section, who produce such materials at an off-site facility shall be paid the applicable prevailing wage rates for the county in which the off-site facility is located. Workers subject to subsection (2) of this section, who deliver such materials to a public works project site shall be paid the applicable prevailing wage rates for the county in which the public works project is located.

[Statutory Authority: Chapter 39.12 RCW, RCW 43.22.051 and 43.22.270. 08-24-101, § 296-127-018, filed 12/2/08, effective 1/2/09. Statutory Authority: Chapters 39.04 and 39.12 RCW and RCW 43.22.270. 92-01-104 and 92-08-101, § 296-127-018, filed 12/18/91 and 4/1/92, effective 8/31/92.]

Benefit Code Key – Effective 3/3/2023 thru 8/30/2023

Overtime Codes

Overtime calculations are based on the hourly rate actually paid to the worker. On public works projects, the hourly rate must be not less than the prevailing rate of wage minus the hourly rate of the cost of fringe benefits actually provided for the worker.

- 1. ALL HOURS WORKED IN EXCESS OF EIGHT (8) HOURS PER DAY OR FORTY (40) HOURS PER WEEK SHALL BE PAID AT ONE AND ONE-HALF TIMES THE HOURLY RATE OF WAGE.
 - B. All hours worked on Saturdays shall be paid at one and one-half times the hourly rate of wage. All hours worked on Sundays and holidays shall be paid at double the hourly rate of wage.
 - C. The first two (2) hours after eight (8) regular hours Monday through Friday and the first ten (10) hours on Saturday shall be paid at one and one-half times the hourly rate of wage. All other overtime hours and all hours worked on Sundays and holidays shall be paid at double the hourly rate of wage.
 - D. The first two (2) hours before or after a five-eight (8) hour workweek day or a four-ten (10) hour workweek day and the first eight (8) hours worked the next day after either workweek shall be paid at one and one-half times the hourly rate of wage. All additional hours worked and all worked on Sundays and holidays shall be paid at double the hourly rate of wage.
 - E. The first two (2) hours after eight (8) regular hours Monday through Friday and the first eight (8) hours on Saturday shall be paid at one and one-half times the hourly rate of wage. All other hours worked Monday through Saturday, and all hours worked on Sundays and holidays shall be paid at double the hourly rate of wage.
 - F. The first two (2) hours after eight (8) regular hours Monday through Friday and the first ten (10) hours on Saturday shall be paid at one and one-half times the hourly rate of wage. All other overtime hours worked, except Labor Day, shall be paid at double the hourly rate of wage. All hours worked on Labor Day shall be paid at three times the hourly rate of wage.
 - G. The first ten (10) hours worked on Saturdays and the first ten (10) hours worked on a fifth calendar weekday in a four-ten hour schedule, shall be paid at one and one-half times the hourly rate of wage. All hours worked in excess of ten (10) hours per day Monday through Saturday and all hours worked on Sundays and holidays shall be paid at double the hourly rate of wage.
 - H. All hours worked on Saturdays (except makeup days if work is lost due to inclement weather conditions or equipment breakdown) shall be paid at one and one-half times the hourly rate of wage. All hours worked Monday through Saturday over twelve (12) hours and all hours worked on Sundays and holidays shall be paid at double the hourly rate of wage.
 - I. All hours worked on Sundays and holidays shall also be paid at double the hourly rate of wage.
 - J. The first two (2) hours after eight (8) regular hours Monday through Friday and the first ten (10) hours on Saturday shall be paid at one and one-half times the hourly rate of wage. All hours worked over ten (10) hours Monday through Saturday, Sundays and holidays shall be paid at double the hourly rate of wage.
 - K. All hours worked on Saturdays and Sundays shall be paid at one and one-half times the hourly rate of wage. All hours worked on holidays shall be paid at double the hourly rate of wage.
 - M. All hours worked on Saturdays (except makeup days if work is lost due to inclement weather conditions) shall be paid at one and one-half times the hourly rate of wage. All hours worked on Sundays and holidays shall be paid at double the hourly rate of wage.
 - N. All hours worked on Saturdays (except makeup days) shall be paid at one and one-half times the hourly rate of wage. All hours worked on Sundays and holidays shall be paid at double the hourly rate of wage.

Benefit Code Key – Effective 3/3/2023 thru 8/30/2023

Overtime Codes Continued

1. O. The first ten (10) hours worked on Saturday shall be paid at one and one-half times the hourly rate of wage. All hours worked on Sundays, holidays and after twelve (12) hours, Monday through Friday and after ten (10) hours on Saturday shall be paid at double the hourly rate of wage.
- P. All hours worked on Saturdays (except makeup days if circumstances warrant) and Sundays shall be paid at one and one-half times the hourly rate of wage. All hours worked on holidays shall be paid at double the hourly rate of wage.
- Q. The first two (2) hours after eight (8) regular hours Monday through Friday and up to ten (10) hours worked on Saturdays shall be paid at one and one-half times the hourly rate of wage. All hours worked in excess of ten (10) hours per day Monday through Saturday and all hours worked on Sundays and holidays (except Christmas day) shall be paid at double the hourly rate of wage. All hours worked on Christmas day shall be paid at two and one-half times the hourly rate of wage.
- R. All hours worked on Sundays and holidays shall be paid at two times the hourly rate of wage.
- U. All hours worked on Saturdays shall be paid at one and one-half times the hourly rate of wage. All hours worked on Sundays and holidays (except Labor Day) shall be paid at two times the hourly rate of wage. All hours worked on Labor Day shall be paid at three times the hourly rate of wage.
- V. All hours worked on Sundays and holidays (except Thanksgiving Day and Christmas day) shall be paid at one and one-half times the hourly rate of wage. All hours worked on Thanksgiving Day and Christmas day shall be paid at double the hourly rate of wage.
- W. All hours worked on Saturdays and Sundays (except make-up days due to conditions beyond the control of the employer)) shall be paid at one and one-half times the hourly rate of wage. All hours worked on holidays shall be paid at double the hourly rate of wage.
- X. The first four (4) hours after eight (8) regular hours Monday through Friday and the first twelve (12) hours on Saturday shall be paid at one and one-half times the hourly rate of wage. All hours worked over twelve (12) hours Monday through Saturday, Sundays and holidays shall be paid at double the hourly rate of wage. When holiday falls on Saturday or Sunday, the day before Saturday, Friday, and the day after Sunday, Monday, shall be considered the holiday and all work performed shall be paid at double the hourly rate of wage.
- Y. All hours worked outside the hours of 5:00 am and 5:00 pm (or such other hours as may be agreed upon by any employer and the employee) and all hours worked in excess of eight (8) hours per day (10 hours per day for a 4 x 10 workweek) and on Saturdays and holidays (except labor day) shall be paid at one and one-half times the hourly rate of wage. (except for employees who are absent from work without prior approval on a scheduled workday during the workweek shall be paid at the straight-time rate until they have worked 8 hours in a day (10 in a 4 x 10 workweek) or 40 hours during that workweek.) All hours worked Monday through Saturday over twelve (12) hours and all hours worked on Sundays and Labor Day shall be paid at double the hourly rate of wage.
- Z. All hours worked on Saturdays and Sundays shall be paid at one and one-half times the hourly rate of wage. All hours worked on holidays shall be paid the straight time rate of pay in addition to holiday pay.

Benefit Code Key – Effective 3/3/2023 thru 8/30/2023

Overtime Codes Continued

2. ALL HOURS WORKED IN EXCESS OF EIGHT (8) HOURS PER DAY OR FORTY (40) HOURS PER WEEK SHALL BE PAID AT ONE AND ONE-HALF TIMES THE HOURLY RATE OF WAGE.

- B. All hours worked on holidays shall be paid at one and one-half times the hourly rate of wage.
- F. The first eight (8) hours worked on holidays shall be paid at the straight hourly rate of wage in addition to the holiday pay. All hours worked in excess of eight (8) hours on holidays shall be paid at double the hourly rate of wage.
- M. This code appears to be missing. All hours worked on Saturdays, Sundays and holidays shall be paid at double the hourly rate of wage.
- O. All hours worked on Sundays and holidays shall be paid at one and one-half times the hourly rate of wage.
- R. All hours worked on Sundays and holidays and all hours worked over sixty (60) in one week shall be paid at double the hourly rate of wage.
- U. All hours worked on Saturdays shall be paid at one and one-half times the hourly rate of wage. All hours worked over 12 hours in a day or on Sundays and holidays shall be paid at double the hourly rate of wage.

3. ALL HOURS WORKED IN EXCESS OF EIGHT (8) HOURS PER DAY OR FORTY (40) HOURS PER WEEK SHALL BE PAID AT ONE AND ONE-HALF TIMES THE HOURLY RATE OF WAGE.

- F. All hours worked on Saturday shall be paid at one and one-half times the hourly rate of wage. All hours worked on Sunday shall be paid at two times the hourly rate of wage. All hours worked on paid holidays shall be paid at two and one-half times the hourly rate of wage including holiday pay.
- H. All work performed on Sundays between March 16th and October 14th and all Holidays shall be compensated for at two (2) times the regular rate of pay. Work performed on Sundays between October 15th and March 15th shall be compensated at one and one half (1-1/2) times the regular rate of pay.
- J. All hours worked between the hours of 10:00 pm and 5:00 am, Monday through Friday, and all hours worked on Saturdays shall be paid at a one and one-half times the hourly rate of wage. All hours worked on Sundays and holidays shall be paid at double the hourly rate of wage.
- K. Work performed in excess of eight (8) hours of straight time per day, or ten (10) hours of straight time per day when four ten (10) hour shifts are established, or forty (40) hours of straight time per week, Monday through Friday, or outside the normal 5 am to 6pm shift, and all work on Saturdays shall be paid at one and one-half times the hourly rate of wage. All work performed after 6:00 pm Saturday to 5:00 am Monday and Holidays, and all hours worked in excess of twelve (12) hours in a single shift shall be paid at double the hourly rate of wage.

After an employee has worked eight (8) hours at an applicable overtime rate, all additional hours shall be at the applicable overtime rate until such time as the employee has had a break of eight (8) hours or more. When an employee returns to work without at least eight (8) hours time off since their previous shift, all such time shall be a continuation of shift and paid at the applicable overtime rate until he/she shall have the eight (8) hours rest period.

Benefit Code Key – Effective 3/3/2023 thru 8/30/2023

Overtime Codes Continued

4. ALL HOURS WORKED IN EXCESS OF EIGHT (8) HOURS PER DAY OR FORTY (40) HOURS PER WEEK SHALL BE PAID AT ONE AND ONE-HALF TIMES THE HOURLY RATE OF WAGE.

- A. All hours worked in excess of eight (8) hours per day or forty (40) hours per week shall be paid at double the hourly rate of wage. All hours worked on Saturdays, Sundays and holidays shall be paid at double the hourly rate of wage
- C. On Monday through Friday, the first four (4) hours of overtime after eight (8) hours of straight time work shall be paid at one and one half (1-1/2) times the straight time rate of pay, unless a four (4) day ten (10) hour workweek has been established. On a four (4) day ten (10) hour workweek scheduled Monday through Thursday, or Tuesday through Friday, the first two (2) hours of overtime after ten (10) hours of straight time work shall be paid at one and one half (1-1/2) times the straight time rate of pay. On Saturday, the first twelve (12) hours of work shall be paid at one and one half (1-1/2) times the straight time rate of pay, except that if the job is down on Monday through Friday due to weather conditions or other conditions outside the control of the employer, the first ten (10) hours on Saturday may be worked at the straight time rate of pay. All hours worked over twelve (12) hours in a day and all hours worked on Sunday and Holidays shall be paid at two (2) times the straight time rate of pay.
- D. All hours worked in excess of eight (8) hours per day or forty (40) hours per week shall be paid at double the hourly rate of wage. All hours worked on Saturday, Sundays and holidays shall be paid at double the hourly rate of pay. Rates include all members of the assigned crew.

EXCEPTION:

On all multipole structures and steel transmission lines, switching stations, regulating, capacitor stations, generating plants, industrial plants, associated installations and substations, except those substations whose primary function is to feed a distribution system, will be paid overtime under the following rates:

The first two (2) hours after eight (8) regular hours Monday through Friday of overtime on a regular workday, shall be paid at one and one-half times the hourly rate of wage. All hours in excess of ten (10) hours will be at two (2) times the hourly rate of wage. The first eight (8) hours worked on Saturday will be paid at one and one-half (1-1/2) times the hourly rate of wage. All hours worked in excess of eight (8) hours on Saturday, and all hours worked on Sundays and holidays will be at the double the hourly rate of wage.

All overtime eligible hours performed on the above described work that is energized, shall be paid at the double the hourly rate of wage.

- E. The first two (2) hours after eight (8) regular hours Monday through Friday and the first eight (8) hours on Saturday shall be paid at one and one-half times the hourly rate of wage. All other hours worked Monday through Saturday, and all hours worked on Sundays and holidays shall be paid at double the hourly rate of wage.

On a four-day, ten-hour weekly schedule, either Monday thru Thursday or Tuesday thru Friday schedule, all hours worked after ten shall be paid at double the hourly rate of wage. The Monday or Friday not utilized in the normal four-day, ten hour work week, and Saturday shall be paid at one and one half (1½) times the regular shift rate for the first eight (8) hours. All other hours worked Monday through Saturday, and all hours worked on Sundays and holidays shall be paid at double the hourly rate of wage.
- G. All hours worked on Saturdays shall be paid at one and one-half times the hourly rate of wage. All hours worked Monday through Saturday over twelve (12) hours and all hours worked on Sundays and holidays shall be paid at double the hourly rate of wage.
- I. The First eight (8) hours worked on Saturdays shall be paid at one and one-half times the hourly rate of wage. All hours worked in excess of eight (8) per day on Saturdays shall be paid at double the hourly rate of wage. All hours worked on Sundays and holidays shall be paid at double the hourly rate of wage.

Benefit Code Key – Effective 3/3/2023 thru 8/30/2023

Overtime Codes Continued

4. J. The first eight (8) hours worked on a Saturday shall be paid at one and one-half times the hourly rate of wage. All hours worked in excess of eight (8) hours on a Saturday shall be paid at double the hourly rate of wage. All hours worked over twelve (12) in a day, and all hours worked on Sundays and Holidays shall be paid at double the hourly rate of wage.
- K. All hours worked on a Saturday shall be paid at one and one-half times the hourly rate of wage, so long as Saturday is the sixth consecutive day worked. All hours worked over twelve (12) in a day Monday through Saturday, and all hours worked on Sundays and Holidays shall be paid at double the hourly rate of wage.
- L. The first twelve (12) hours worked on a Saturday shall be paid at one and one-half times the hourly rate of wage. All hours worked on a Saturday in excess of twelve (12) hours shall be paid at double the hourly rate of pay. All hours worked over twelve (12) in a day Monday through Friday, and all hours worked on Sundays shall be paid at double the hourly rate of wage. All hours worked on a holiday shall be paid at one and one-half times the hourly rate of wage, except that all hours worked on Labor Day shall be paid at double the hourly rate of pay.
- U. The first four (4) hours after eight (8) regular hours Monday through Friday and the first twelve (12) hours on Saturday shall be paid at one and one-half times the hourly rate of wage. (Except on makeup days if work is lost due to inclement weather, then the first eight (8) hours on Saturday may be paid the regular rate.) All hours worked over twelve (12) hours Monday through Saturday, and all hours worked on Sundays and holidays shall be paid at double the hourly rate of wage.
- S. On a four (4) day ten (10) hour workweek scheduled Monday through Thursday, or Tuesday through Friday, work performed in excess of (10) hours shall be paid at one and one half (1-1/2) times the hourly rate of pay. On Monday through Friday, work performed outside the normal work hours of 6:00 a.m. and 6:00 p.m. shall be paid at one and one-half (1-1/2) times the straight time rate, (except for special shifts or multiple shift operations).

All hours worked on Saturdays shall be paid at one and one-half times the hourly rate of wage. All work performed on Sundays and holidays shall be paid at double the hourly rate of wage. When an employee returns to work without at least eight (8) hours time off since their previous shift, all such time shall be a continuation of shift and paid at the applicable overtime rate until such time as the employee has had a break of eight (8) hours.

Multiple Shift Operations: When the first shift of a multiple shift (a two or three shift) operation is started at the basic straight time rate or at a specific overtime rate, all shifts of that day's operation shall be completed at that rate. Special Shifts: The Special Shift Premium is the basic hourly rate of pay plus \$2.00 an hour. When due to conditions beyond the control of the employer or when an owner (not acting as the contractor), a government agency or the contract specifications require more than four (4) hours of a special shift can only be performed outside the normal 6am to 6pm shift then the special shift premium will be applied to the basic straight time for the entire shift. When an employee works on a special shift, they shall be paid the special shift premium for each hour worked unless they are in overtime or double-time status. (For example, the special shift premium does not waive the overtime requirements for work performed on Saturday or Sunday).

Benefit Code Key – Effective 3/3/2023 thru 8/30/2023

Overtime Codes Continued

4. V. Work performed in excess of ten (10) hours of straight time per day when four ten (10) hour shifts are established or outside the normal shift (5 am to 6pm), and all work on Saturdays, except for make-up days shall be paid at time and one-half (1 ½) the straight time rate.

In the event the job is down due to weather conditions, then Saturday may, be worked as a voluntary make-up day at the straight time rate. However, Saturday shall not be utilized as a make-up day when a holiday falls on Friday. All work performed on Sundays and holidays and work in excess of twelve (12) hours per day shall be paid at double (2x) the straight time rate of pay.

After an employee has worked eight (8) hours at an applicable overtime rate, all additional hours shall be at the applicable overtime rate until such time as the employee has had a break of eight (8) hours.

When an employee returns to work without a break of eight (8) hours since their previous shift, all such time shall be a continuation of shift and paid at the applicable overtime rate until such time as the employee has had a break of eight (8) hours.

- X. All hours worked on Saturdays shall be paid at one and one-half times the hourly rate of wage. All hours worked on Sundays and holidays shall be paid at double the hourly rate of wage. Work performed outside the normal shift of 6 am to 6pm shall be paid at one and one-half the straight time rate, (except for special shifts or three shift operations). All work performed on Sundays and holidays shall be paid at double the hourly rate of wage. Shifts may be established when considered necessary by the Employer.

The Employer may establish shifts consisting of eight (8) or ten (10) hours of work (subject to WAC 296-127-022), that shall constitute a normal forty (40) hour work week. The Employer can change from a 5-eight to a 4-ten hour schedule or back to the other. All hours of work on these shifts shall be paid for at the straight time hourly rate. Work performed in excess of eight hours (or ten hours per day (subject to WAC 296-127-022) shall be paid at one and one-half the straight time rate.

When due to conditions beyond the control of the Employer, or when contract specifications require that work can only be performed outside the regular day shift, then by mutual agreement a special shift may be worked at the straight time rate, eight (8) hours work for eight (8) hours pay. The starting time shall be arranged to fit such conditions of work.

When an employee returns to work without at a break of eight (8) hours since their previous shift, all such time shall be a continuation of shift and paid at the applicable overtime rate until such time as the employee has had a break of eight (8) hours.

11. ALL HOURS WORKED IN EXCESS OF EIGHT (8) HOURS PER DAY OR FORTY (40) HOURS PER WEEK SHALL BE PAID AT ONE AND ONE-HALF TIMES THE HOURLY RATE OF WAGE.

- B After an employee has worked eight (8) hours, all additional hours worked shall be paid at the applicable overtime rate until such time as the employee has had a break of eight (8) hours or more.

- C The first two (2) hours after eight (8) regular hours Monday through Friday and the first eight (8) hours on Saturday shall be paid at one and one-half times the hourly rate of wage. All other overtime hours worked, except Labor Day, and all hours on Sunday shall be paid at double the hourly rate of wage. All hours worked on Labor Day shall be paid at three times the hourly rate of wage. All non-overtime and non-holiday hours worked between 4:00 pm and 5:00 am, Monday through Friday, shall be paid at a premium rate of 15% over the hourly rate of wage.

Benefit Code Key – Effective 3/3/2023 thru 8/30/2023

Overtime Codes Continued

11. D. All hours worked on Saturdays and holidays shall be paid at one and one-half times the hourly rate of wage. All hours worked on Sundays shall be paid at double the hourly rate of wage.

After an employee has worked eight (8) hours, all additional hours worked shall be paid at the applicable overtime rate until such time as the employee has had a break of eight (8) hours or more.

- E. The first two (2) hours after eight (8) regular hours Monday through Friday, the first ten (10) hours on Saturday, and the first ten (10) hours worked on Holidays shall be paid at one and one-half times the hourly rate of wage. All hours worked over ten (10) hours Monday through Saturday, and Sundays shall be paid at double the hourly rate of wage.

After an employee has worked eight (8) hours, all additional hours worked shall be paid at the applicable overtime rate until such time as the employee has had a break of eight (8) hours or more.

- F. The first two (2) hours after eight (8) regular hours Monday through Friday and the first eight (8) hours on Saturday shall be paid at one and one-half times the hourly rate of wage. All other hours worked Monday through Saturday, and all hours worked on Sundays and holidays shall be paid at double the hourly rate of wage.

On a four-day, ten-hour weekly schedule, either Monday thru Thursday or Tuesday thru Friday schedule, all hours worked after ten shall be paid at double the hourly rate of wage. The Monday or Friday not utilized in the normal four-day, ten hour work week, and Saturday shall be paid at one-half times the hourly rate of wage for the first eight (8) hours. All other hours worked Monday through Saturday, and all hours worked on Sundays and holidays shall be paid at double the hourly rate of wage.

- G. Work performed in excess of eight (8) hours of straight time per day, or ten (10) hours of straight time per day when four ten (10) hour shifts are established, or forty (40) hours of straight time per week, Monday through Friday, or outside the normal 5 am to 6pm shift, and all work on Saturdays shall be paid at one and one-half times the hourly rate of wage.

All work performed after 6:00 pm Saturday to 5:00 am Monday and Holidays, and all hours worked in excess of twelve (12) hours in a single shift shall be paid at double the hourly rate of wage.

After an employee has worked eight (8) hours at an applicable overtime rate, all additional hours shall be at the applicable overtime rate until such time as the employee has had a break of nine (9) hours or more. When an employee returns to work without at least nine (9) hours time off since their previous shift, all such time shall be a continuation of shift and paid at the applicable overtime rate until he/she shall have the nine (9) hours rest period.

- H. Work performed in excess of eight (8) hours of straight time per day, or ten (10) hours of straight time per day when four ten (10) hour shifts are established, or forty (40) hours of straight time per week, Monday through Friday, or outside the normal 5 am to 6pm shift, and all work on Saturdays shall be paid at one and one-half times the hourly rate of wage.

All work performed after 6:00 pm Saturday to 5:00 am Monday and Holidays, and all hours worked in excess of twelve (12) hours in a single shift shall be paid at double the hourly rate of wage.

After an employee has worked eight (8) hours at an applicable overtime rate, all additional hours shall be at the applicable overtime rate until such time as the employee has had a break of ten (10) hours or more. When an employee returns to work without at least ten (10) hours time off since their previous shift, all such time shall be a continuation of shift and paid at the applicable overtime rate until he/she shall have the ten (10) hours rest period.

Benefit Code Key – Effective 3/3/2023 thru 8/30/2023

Overtime Codes Continued

11. J. All hours worked on holidays shall be paid at double the hourly rate of wage.
- K. On Monday through Friday hours worked outside 4:00 am and 5:00 pm, and the first two (2) hours after eight (8) hours worked shall be paid at one and one-half times the hourly rate. All hours worked over 10 hours per day Monday through Friday, and all hours worked on Saturdays, Sundays, and Holidays worked shall be paid at double the hourly rate of wage.
- L. An employee working outside 5:00 am and 5:00 pm shall receive an additional two dollar (\$2.00) per hour for all hours worked that shift. All hours worked on holidays shall be paid at one and one-half times the hourly rate of wage. All hours worked on holidays shall be paid at one and one-half times the hourly rate of wage.
- M. On Monday through Friday, the first four (4) hours of overtime after eight (8) hours of straight time work shall be paid at one and one half (1-1/2) times the straight time rate of pay, unless a four (4) day ten (10) hour workweek has been established. On a four (4) day ten (10) hour workweek scheduled Monday through Thursday, or Tuesday through Friday, the first two (2) hours of overtime after ten (10) hours of straight time work shall be paid at one and one half (1-1/2) times the straight time rate of pay.
- Work performed outside the normal work hours of 5:00 a.m. and 6:00 p.m. shall be paid at one and one-half (1-1/2) times the straight time rate, (except for special shifts or multiple shift operations). When the first shift of a multiple shift (a two or three shift) operation is started at the basic straight time rate or at a specific overtime rate, all shifts of that day's operation shall be completed at that rate. When due to conditions beyond the control of the Employer or when contract specifications require that work can only be performed outside the regular day shift of 5:00 am to 6:00 pm, then a special shift may be worked at the straight time rate, plus the shift pay premium when applicable. The starting time of work will be arranged to fit such conditions of work. Such shift shall consist of eight (8) hours work for eight (8) hours pay or ten (10) hours work for ten (10) hours pay for four ten shifts.
- On Saturday, the first twelve (12) hours of work shall be paid at one and one half (1-1/2) times the straight time rate of pay. All work performed after 6:00 pm Saturday to 5:00 am Monday, all work performed over twelve (12) hours, and all work performed on holidays shall be paid at double the straight time rate of pay.
- Shift Pay Premium: In an addition to any overtime already required, all hours worked between the hours of 6:00 pm and 5:00 am shall receive an additional two dollars (\$2.00) per hour.
- N. All work performed over twelve hours in a shift and all work performed on Sundays and Holidays shall be paid at double the straight time rate.
- Any time worked over eight (8) hours on Saturday shall be paid double the straight time rate, except employees assigned to work six 10-hour shifts per week shall be paid double the straight time rate for any time worked on Saturday over 10 hours.

Benefit Code Key – Effective 3/3/2023 thru 8/30/2023

Holiday Codes

- 5. A. Holidays: New Year's Day, Memorial Day, Independence Day, Labor Day, Thanksgiving Day, Friday after Thanksgiving Day, and Christmas Day (7).
- B. Holidays: New Year's Day, Memorial Day, Independence Day, Labor Day, Thanksgiving Day, Friday after Thanksgiving Day, the day before Christmas, and Christmas Day (8).
- C. Holidays: New Year's Day, Presidents' Day, Memorial Day, Independence Day, Labor Day, Thanksgiving Day, the Friday after Thanksgiving Day, And Christmas Day (8).
- D. Holidays: New Year's Day, Memorial Day, Independence Day, Labor Day, Thanksgiving Day, the Friday and Saturday after Thanksgiving Day, And Christmas Day (8).
- H. Holidays: New Year's Day, Memorial Day, Independence Day, Thanksgiving Day, the Day after Thanksgiving Day, And Christmas (6).
- I. Holidays: New Year's Day, Memorial Day, Independence Day, Labor Day, Thanksgiving Day, and Christmas Day (6).
- K. Holidays: New Year's Day, Presidents' Day, Memorial Day, Independence Day, Labor Day, Thanksgiving Day, Friday After Thanksgiving Day, The Day Before Christmas, And Christmas Day (9).
- L. Holidays: New Year's Day, Martin Luther King Jr. Day, Memorial Day, Independence Day, Labor Day, Thanksgiving Day, Friday after Thanksgiving Day, And Christmas Day (8).
- N. Holidays: New Year's Day, Presidents' Day, Memorial Day, Independence Day, Labor Day, Veterans' Day, Thanksgiving Day, The Friday After Thanksgiving Day, And Christmas Day (9).
- P. Holidays: New Year's Day, Memorial Day, Independence Day, Labor Day, Thanksgiving Day, Friday And Saturday After Thanksgiving Day, The Day Before Christmas, And Christmas Day (9). If A Holiday Falls On Sunday, The Following Monday Shall Be Considered As A Holiday.
- Q. Paid Holidays: New Year's Day, Memorial Day, Independence Day, Labor Day, Thanksgiving Day, and Christmas Day (6).
- R. Paid Holidays: New Year's Day, Memorial Day, Independence Day, Labor Day, Thanksgiving Day, Day After Thanksgiving Day, One-Half Day Before Christmas Day, And Christmas Day. (7 1/2).
- S. Paid Holidays: New Year's Day, Presidents' Day, Memorial Day, Independence Day, Labor Day, Thanksgiving Day, And Christmas Day (7).
- Z. Holidays: New Year's Day, Memorial Day, Independence Day, Labor Day, Veterans Day, Thanksgiving Day, the Friday after Thanksgiving Day, And Christmas Day (8).
- 6. G. Paid Holidays: New Year's Day, Martin Luther King Jr. Day, Presidents' Day, Memorial Day, Independence Day, Labor Day, Veterans' Day, Thanksgiving Day, the Friday after Thanksgiving Day, Christmas Day, and Christmas Eve Day (11).
- H. Paid Holidays: New Year's Day, New Year's Eve Day, Memorial Day, Independence Day, Labor Day, Thanksgiving Day, Friday After Thanksgiving Day, Christmas Day, The Day After Christmas, And A Floating Holiday (10).

Benefit Code Key – Effective 3/3/2023 thru 8/30/2023

Holiday Codes Continued

6. T. Paid Holidays: New Year's Day, Presidents' Day, Memorial Day, Independence Day, Labor Day, Thanksgiving Day, The Friday After Thanksgiving Day, The Last Working Day Before Christmas Day, And Christmas Day (9).
- Z. Holidays: New Year's Day, Memorial Day, Independence Day, Labor Day, Thanksgiving Day, Friday after Thanksgiving Day, And Christmas Day (7). If a holiday falls on Saturday, the preceding Friday shall be considered as the holiday. If a holiday falls on Sunday, the following Monday shall be considered as the holiday.
7. A. Holidays: New Year's Day, Memorial Day, Independence Day, Labor Day, Thanksgiving Day, the Friday and Saturday after Thanksgiving Day, And Christmas Day (8). Any Holiday Which Falls On A Sunday Shall Be Observed As A Holiday On The Following Monday. If any of the listed holidays falls on a Saturday, the preceding Friday shall be a regular work day.
- B. Holidays: New Year's Day, Memorial Day, Independence Day, Labor Day, Thanksgiving Day, the Friday and Saturday after Thanksgiving Day, And Christmas Day (8). Any holiday which falls on a Sunday shall be observed as a holiday on the following Monday. Any holiday which falls on a Saturday shall be observed as a holiday on the preceding Friday.
- C. Holidays: New Year's Day, Martin Luther King Jr. Day, Memorial Day, Independence Day, Labor Day, Thanksgiving Day, the Friday after Thanksgiving Day, And Christmas Day (8). Any holiday which falls on a Sunday shall be observed as a holiday on the following Monday. Any holiday which falls on a Saturday shall be observed as a holiday on the preceding Friday.
- D. Paid Holidays: New Year's Day, Memorial Day, Independence Day, Labor Day, Veteran's Day, Thanksgiving Day, the Friday after Thanksgiving Day, And Christmas Day (8). Unpaid Holidays: President's Day. Any paid holiday which falls on a Sunday shall be observed as a holiday on the following Monday. Any paid holiday which falls on a Saturday shall be observed as a holiday on the preceding Friday.
- E. Holidays: New Year's Day, Memorial Day, Independence Day, Labor Day, Thanksgiving Day, the Friday after Thanksgiving Day, And Christmas Day (7). Any holiday which falls on a Sunday shall be observed as a holiday on the following Monday. Any holiday which falls on a Saturday shall be observed as a holiday on the preceding Friday.
- F. Holidays: New Year's Day, Memorial Day, Independence Day, Labor Day, Thanksgiving Day, the Friday after Thanksgiving Day, the last working day before Christmas day and Christmas day (8). Any holiday which falls on a Sunday shall be observed as a holiday on the following Monday. Any holiday which falls on a Saturday shall be observed as a holiday on the preceding Friday.
- G. Holidays: New Year's Day, Memorial Day, Independence Day, Labor Day, Thanksgiving Day, and Christmas Day (6). Any holiday which falls on a Sunday shall be observed as a holiday on the following Monday.
- H. Holidays: New Year's Day, Martin Luther King Jr. Day, Independence Day, Memorial Day, Labor Day, Thanksgiving Day, the Friday after Thanksgiving Day, the Last Working Day before Christmas Day and Christmas Day (9). Any holiday which falls on a Sunday shall be observed as a holiday on the following Monday. Any holiday which falls on a Saturday shall be observed as a holiday on the preceding Friday.
- I. Holidays: New Year's Day, President's Day, Independence Day, Memorial Day, Labor Day, Thanksgiving Day, The Friday After Thanksgiving Day, The Day Before Christmas Day And Christmas Day (9). Any holiday which falls on a Sunday shall be observed as a holiday on the following Monday. Any holiday which falls on a Saturday shall be observed as a holiday on the preceding Friday.

Benefit Code Key – Effective 3/3/2023 thru 8/30/2023

Holiday Codes Continued

7. J. Holidays: New Year's Day, Independence Day, Memorial Day, Labor Day, Thanksgiving Day and Christmas Day (6). Any holiday which falls on a Sunday shall be observed as a holiday on the following Monday. Any holiday which falls on a Saturday shall be observed as a holiday on the preceding Friday.
- K. Holidays: New Year's Day, Memorial Day, Independence Day, Thanksgiving Day, the Friday and Saturday after Thanksgiving Day, And Christmas Day (8). Any holiday which falls on a Sunday shall be observed as a holiday on the following Monday. Any holiday which falls on a Saturday shall be observed as a holiday on the preceding Friday.
- L. Holidays: New Year's Day, Memorial Day, Labor Day, Independence Day, Thanksgiving Day, the Last Work Day before Christmas Day, And Christmas Day (7). Any holiday which falls on a Sunday shall be observed as a holiday on the following Monday. Any holiday which falls on a Saturday shall be observed as a holiday on the preceding Friday.
- N. Holidays: New Year's Day, Memorial Day, Independence Day, Labor Day, Thanksgiving Day, the Friday after Thanksgiving Day, And Christmas Day (7). Any holiday which falls on a Sunday shall be observed as a holiday on the following Monday. When Christmas falls on a Saturday, the preceding Friday shall be observed as a holiday.
- P. Holidays: New Year's Day, Memorial Day, Independence Day, Labor Day, Thanksgiving Day, Friday after Thanksgiving Day, And Christmas Day (7). Any holiday which falls on a Sunday shall be observed as a holiday on the following Monday.
- Q. Holidays: New Year's Day, Memorial Day, Independence Day, Labor Day, Thanksgiving Day, the Friday after Thanksgiving Day, the Last Working Day before Christmas Day and Christmas Day (8). Any holiday which falls on a Sunday shall be observed as a holiday on the following Monday. If any of the listed holidays falls on a Saturday, the preceding Friday shall be a regular work day.
- S. Paid Holidays: New Year's Day, Memorial Day, Independence Day, Labor Day, Thanksgiving Day, Friday after Thanksgiving Day, Christmas Day, the Day after Christmas, and A Floating Holiday (9). If any of the listed holidays falls on a Sunday, the day observed by the Nation shall be considered a holiday and compensated accordingly.
- V. Holidays: New Year's Day, President's Birthday, Memorial Day, Independence Day, Labor Day, Thanksgiving Day, the Friday after Thanksgiving Day, Christmas Day, the day before or after Christmas, and the day before or after New Year's Day. If any of the above listed holidays falls on a Sunday, the day observed by the Nation shall be considered a holiday and compensated accordingly.
- W. Holidays: New Year's Day, Day After New Year's, Memorial Day, Independence Day, Labor Day, Thanksgiving Day, the Friday after Thanksgiving Day, Christmas Eve Day, Christmas Day, the day after Christmas, the day before New Year's Day, and a Floating Holiday.
- X. Holidays: New Year's Day, Day before or after New Year's Day, Presidents' Day, Memorial Day, Independence Day, Labor Day, Thanksgiving Day, the Friday after Thanksgiving Day, Christmas Day, and the day before or after Christmas day. If a holiday falls on a Saturday or on a Friday that is the normal day off, then the holiday will be taken on the last normal workday. If the holiday falls on a Monday that is the normal day off or on a Sunday, then the holiday will be taken on the next normal workday.
- Y. Holidays: New Year's Day, Presidents' Day, Memorial Day, Independence Day, Labor Day, Thanksgiving Day, the Friday after Thanksgiving Day, and Christmas Day. (8) If the holiday falls on a Sunday, then the day observed by the federal government shall be considered a holiday and compensated accordingly.
- Z. Holidays: New Year's Day, Memorial Day, Independence Day, Labor Day, Thanksgiving Day, the Friday and Saturday after Thanksgiving Day, Christmas Eve, and Christmas Day (9). Any holiday which falls on a Saturday shall be observed as a holiday on the preceding Friday. Any holiday which falls on a Sunday shall be observed as a holiday on the following Monday.

Benefit Code Key – Effective 3/3/2023 thru 8/30/2023

Holiday Codes Continued

15. G. New Year's Day, Washington's Birthday, Memorial Day, Independence Day, Labor Day, Thanksgiving Day, The Friday After Thanksgiving Day, the last scheduled workday before Christmas, and Christmas Day (9). If any of the listed holidays falls on a Sunday, the day observed by the Nation shall be considered a holiday and compensated accordingly.
- H. Holidays: New Year's Day, Martin Luther King Jr. Day, Independence Day, Memorial Day, Labor Day, Thanksgiving Day, the Friday after Thanksgiving Day, the Last Working Day before Christmas Day and Christmas Day (9). Any holiday which falls on a Sunday shall be observed as a holiday on the following Monday. Any holiday which falls on a Saturday shall be observed as a holiday on the preceding Friday.
- I. Holidays: New Year's Day, President's Day, Independence Day, Memorial Day, Labor Day, Thanksgiving Day, The Friday After Thanksgiving Day, The Day Before Christmas Day And Christmas Day (9). Any holiday which falls on a Sunday shall be observed as a holiday on the following Monday. Any holiday which falls on a Saturday shall be observed as a holiday on the preceding Friday.
- J. Holidays: New Year's Day, Independence Day, Memorial Day, Labor Day, Thanksgiving Day and Christmas Day (6). Any holiday which falls on a Sunday shall be observed as a holiday on the following Monday. Any holiday which falls on a Saturday shall be observed as a holiday on the preceding Friday.
- K. Holidays: New Year's Day, Memorial Day, Independence Day, Thanksgiving Day, the Friday and Saturday after Thanksgiving Day, And Christmas Day (8). Any holiday which falls on a Sunday shall be observed as a holiday on the following Monday. Any holiday which falls on a Saturday shall be observed as a holiday on the preceding Friday.

Note Codes

8. D. Workers working with supplied air on hazmat projects receive an additional \$1.00 per hour.
- L. Workers on hazmat projects receive additional hourly premiums as follows -Level A: \$0.75, Level B: \$0.50, And Level C: \$0.25.
- M. Workers on hazmat projects receive additional hourly premiums as follows: Levels A & B: \$1.00, Levels C & D: \$0.50.
- N. Workers on hazmat projects receive additional hourly premiums as follows -Level A: \$1.00, Level B: \$0.75, Level C: \$0.50, And Level D: \$0.25.
- S. Effective August 31, 2012 – A Traffic Control Supervisor shall be present on the project whenever flagging or spotting or other traffic control labor is being utilized. Flaggers and Spotters shall be posted where shown on approved Traffic Control Plans or where directed by the Engineer. All flaggers and spotters shall possess a current flagging card issued by the State of Washington, Oregon, Montana, or Idaho. This classification is only effective on or after August 31, 2012.
- T. Effective August 31, 2012 – A Traffic Control Laborer performs the setup, maintenance and removal of all temporary traffic control devices and construction signs necessary to control vehicular, bicycle, and pedestrian traffic during construction operations. Flaggers and Spotters shall be posted where shown on approved Traffic Control Plans or where directed by the Engineer. All flaggers and spotters shall possess a current flagging card issued by the State of Washington, Oregon, Montana, or Idaho. This classification is only effective on or after August 31, 2012.

Benefit Code Key – Effective 3/3/2023 thru 8/30/2023

Note Codes Continued

8. U. Workers on hazmat projects receive additional hourly premiums as follows – Class A Suit: \$2.00, Class B Suit: \$1.50, And Class C Suit: \$1.00. Workers performing underground work receive an additional \$0.40 per hour for any and all work performed underground, including operating, servicing and repairing of equipment. The premium for underground work shall be paid for the entire shift worked. Workers who work suspended by a rope or cable receive an additional \$0.50 per hour. The premium for work suspended shall be paid for the entire shift worked. Workers who do “pioneer” work (break open a cut, build road, etc.) more than one hundred fifty (150) feet above grade elevation receive an additional \$0.50 per hour.
- V. In addition to the hourly wage and fringe benefits, the following depth and enclosure premiums shall be paid. The premiums are to be calculated for the maximum depth and distance into an enclosure that a diver reaches in a day. The premiums are to be paid one time for the day and are not used in calculating overtime pay.
- Depth premiums apply to depths of fifty feet or more. Over 50' to 100' - \$2.00 per foot for each foot over 50 feet. Over 101' to 150' - \$3.00 per foot for each foot over 101 feet. Over 151' to 220' - \$4.00 per foot for each foot over 220 feet. Over 221' - \$5.00 per foot for each foot over 221 feet.
- Enclosure premiums apply when divers enter enclosures (such as pipes or tunnels) where there is no vertical ascent and is measured by the distance travelled from the entrance. 25' to 300' - \$1.00 per foot from entrance. 300' to 600' - \$1.50 per foot beginning at 300'. Over 600' - \$2.00 per foot beginning at 600'.
- W. Meter Installers work on single phase 120/240V self-contained residential meters. The Lineman/Groundmen rates would apply to meters not fitting this description.
- X. Workers on hazmat projects receive additional hourly premiums as follows - Class A Suit: \$2.00, Class B Suit: \$1.50, Class C Suit: \$1.00, and Class D Suit: \$0.50. Special Shift Premium: Basic hourly rate plus \$2.00 per hour.
- When due to conditions beyond the control of the Employer or when an owner (not acting as the contractor), a government agency or the contract specifications requires that work can only be performed outside the normal 5 am to 6pm shift, then the special shift premium will be applied to the basic hourly rate. When an employee works on a special shift, they shall be paid a special shift premium for each hour worked unless they are in OT or Double-time status. (For example, the special shift premium does not waive the overtime requirements for work performed on Saturday or Sunday.)
- Y. Tide Work: When employees are called out between the hours of 6:00 p.m. and 6:00 a.m. to work on tide work (work located in the tide plane) all time worked shall be at one and one-half times the hourly rate of pay.
- Swinging Stage/Boatswains Chair: Employees working on a swinging state or boatswains chair or under conditions that require them to be tied off to allow their hands to be free shall receive seventy-five cents (\$0.75) per hour above the classification rate.
- Z. Workers working with supplied air on hazmat projects receive an additional \$1.00 per hour.
- Special Shift Premium: Basic hourly rate plus \$2.00 per hour. When due to conditions beyond the control of the Employer or when an owner (not acting as a contractor), a government agency or the contract specifications require that more than (4) hours of a special shift can only be performed outside the normal 6 am to 6pm shift, then the special shift premium will be applied to the basic straight time for the entire shift. When an employee works on a special shift, they will be paid a special shift premium for each hour worked unless they are in overtime or double-time status. (For example, the special shift premium does not waive the overtime requirements for work performed on Saturday or Sunday.)

Benefit Code Key – Effective 3/3/2023 thru 8/30/2023

Note Codes Continued

9. A. Workers working with supplied air on hazmat projects receive an additional \$1.00 per hour.

Special Shift Premium: Basic hourly rate plus \$2.00 per hour. When due to conditions beyond the control of the Employer or when an owner (not acting as the contractor), a government agency or the contract specifications require that more than four (4) hours of a special shift can only be performed outside the normal 6 am to 6pm shift, then the special shift premium will be applied to the basic straight time for the entire shift. When an employee works on a special shift, they shall be paid a special shift premium for each hour worked unless they are in overtime or double-time status. (For example, the special shift premium does not waive the overtime requirements for work performed on Saturday or Sunday.)

Certified Crane Operator Premium: Crane operators requiring certifications shall be paid \$0.50 per hour above their classification rate.

Boom Pay Premium: All cranes including tower shall be paid as follows based on boom length:

(A) – 130' to 199' – \$0.50 per hour over their classification rate.

(B) – 200' to 299' – \$0.80 per hour over their classification rate.

(C) – 300' and over – \$1.00 per hour over their classification rate.

- B. The highest pressure registered on the gauge for an accumulated time of more than fifteen (15) minutes during the shift shall be used in determining the scale paid.

Tide Work: When employees are called out between the hours of 6:00 p.m. and 6:00 a.m. to work on tide work (work located in the tide plane) all time worked shall be at one and one-half times the hourly rate of pay. Swinging Stage/Boatswains Chair: Employees working on a swinging stage or boatswains chair or under conditions that require them to be tied off to allow their hands to be free shall receive seventy-five cents (\$0.75) per hour above the classification rate.

- C. Tide Work: When employees are called out between the hours of 6:00 p.m. and 6:00 a.m. to work on tide work (work located in the tide plane) all time worked shall be at one and one-half times the hourly rate of pay. Swinging Stage/Boatswains Chair: Employees working on a swinging stage or boatswains chair or under conditions that require them to be tied off to allow their hands to be free shall receive seventy-five cents (\$0.75) per hour above the classification rate.

Effective August 31, 2012 – A Traffic Control Supervisor shall be present on the project whenever flagging or spotting or other traffic control labor is being utilized. A Traffic Control Laborer performs the setup, maintenance and removal of all temporary traffic control devices and construction signs necessary to control vehicular, bicycle, and pedestrian traffic during construction operations. Flaggers and Spotters shall be posted where shown on approved Traffic Control Plans or where directed by the Engineer. All flaggers and spotters shall possess a current flagging card issued by the State of Washington, Oregon, Montana, or Idaho. These classifications are only effective on or after August 31, 2012.

- D. Industrial Painter wages are required for painting within industrial facilities such as treatment plants, pipelines, towers, dams, bridges, power generation facilities and manufacturing facilities such as chemical plants, etc., or anywhere abrasive blasting is necessary to prepare surfaces, or hazardous materials encapsulation is required.
- E. Heavy Construction includes construction, repair, alteration or additions to the production, fabrication or manufacturing portions of industrial or manufacturing plants, hydroelectric or nuclear power plants and atomic reactor construction. Workers on hazmat projects receive additional hourly premiums as follows -Level A: \$1.00, Level B: \$0.75, Level C: \$0.50, And Level D: \$0.25.
- F. Industrial Painter wages are required for painting within industrial facilities such as treatment plants, pipelines, towers, dams, power generation facilities and manufacturing facilities such as chemical plants, etc., or anywhere abrasive blasting is necessary to prepare surfaces, or hazardous materials encapsulation is required.

Benefit Code Key – Effective 3/3/2023 thru 8/30/2023

Note Codes Continued

9. H. One (1) person crew shall consist of a Party Chief. (Total Station or similar one (1) person survey system). Two (2) person survey party shall consist of a least a Party Chief and a Chain Person. Three (3) person survey party shall consist of at least a Party Chief, an Instrument Person, and a Chain Person.

**APPENDIX B:
MERCER ISLAND TRAFFIC STANDARD DETAILS**

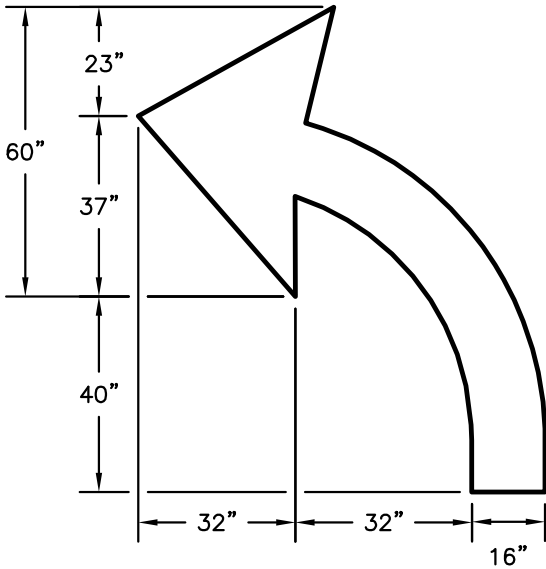
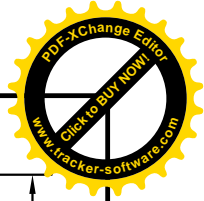
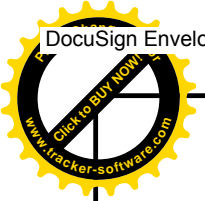

LEFT-TURN ARROW

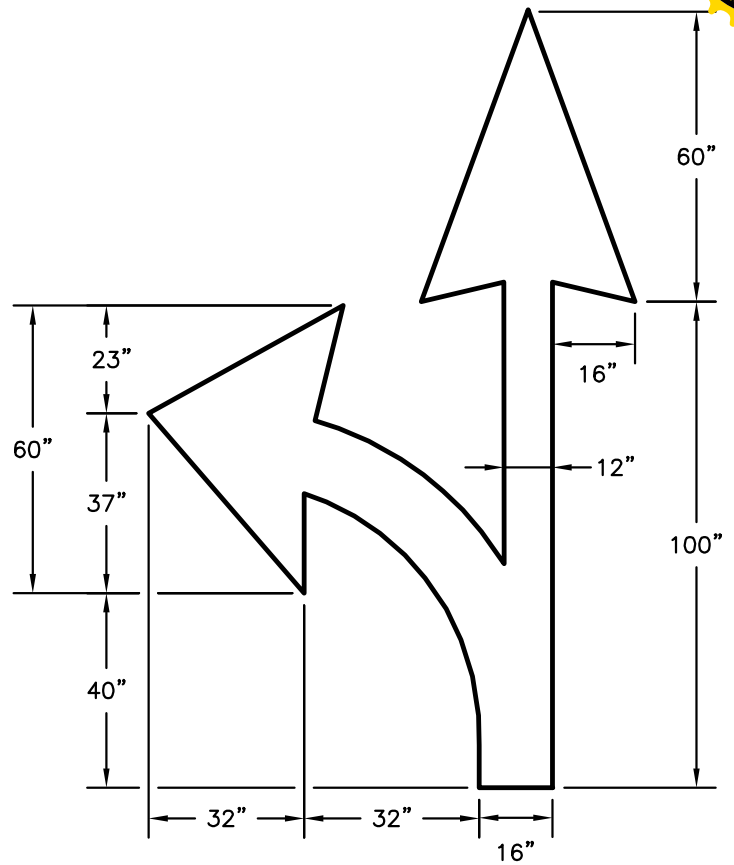

COMBINATION ARROW

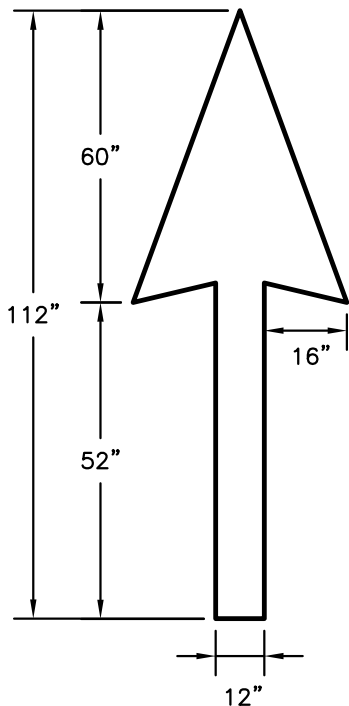

STRAIGHT ARROW



CITY OF MERCER ISLAND
STANDARD DETAILS
STREETS

PAVEMENT MARKINGS
TRAFFIC ARROWS

4/13/2017

NO SCALE

TR-7D

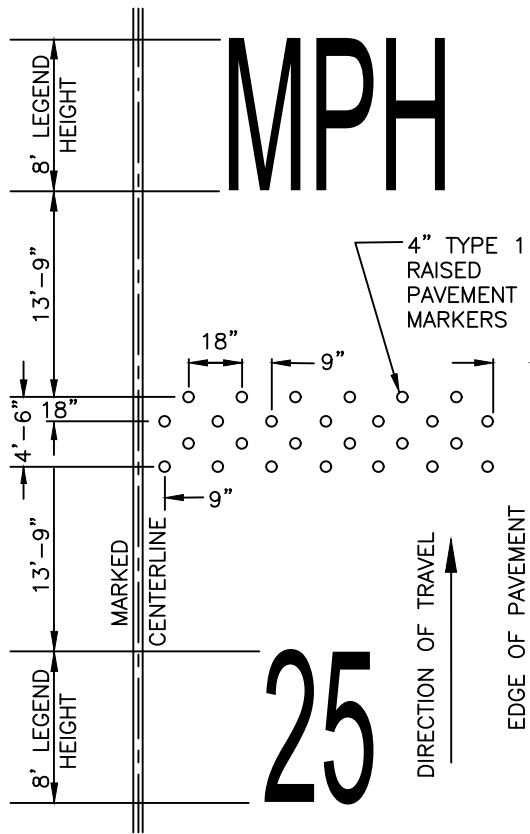
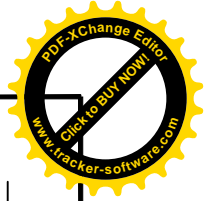
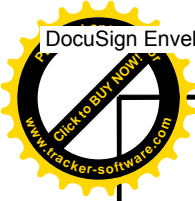

RUMBLE STRIP W/25MPH LEGEND

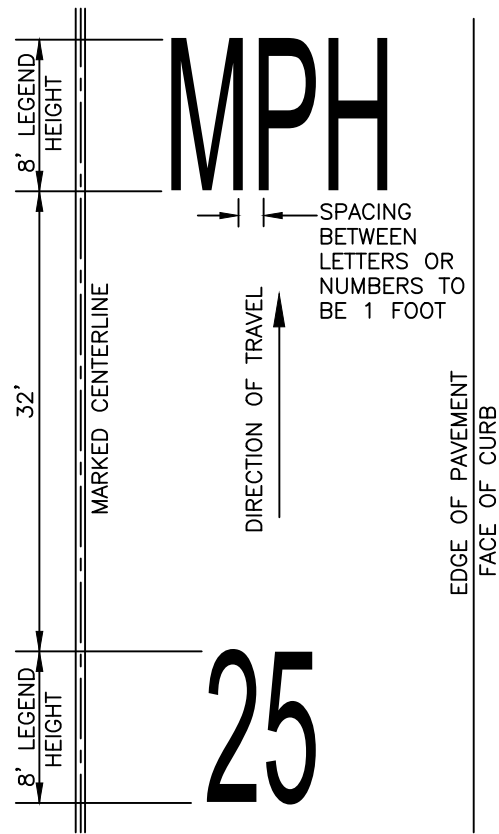

25 MPH LEGEND

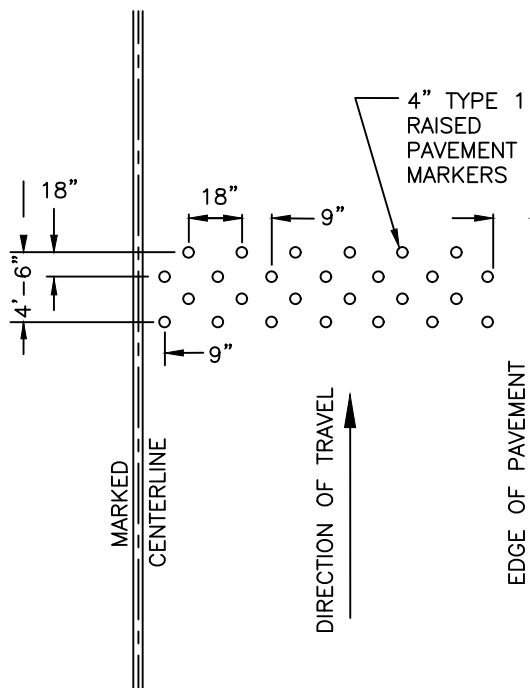

RUMBLE STRIP

NOTES:

1. RUMBLE STRIP SHALL BE PLACED ACROSS ENTIRE ROADWAY WIDTH IF NO CENTERLINE EXISTS.
2. LEGEND MATERIAL USED SHALL BE PREFORMED THERMOPLASTIC (125 MIL. MIN.), UNLESS OTHERWISE APPROVED BY THE ENGINEER.



CITY OF MERCER ISLAND
STANDARD DETAILS
TRAFFIC

RUMBLE STRIP
& 25 MPH LEGEND

12-4-2015

NO SCALE

TR-12

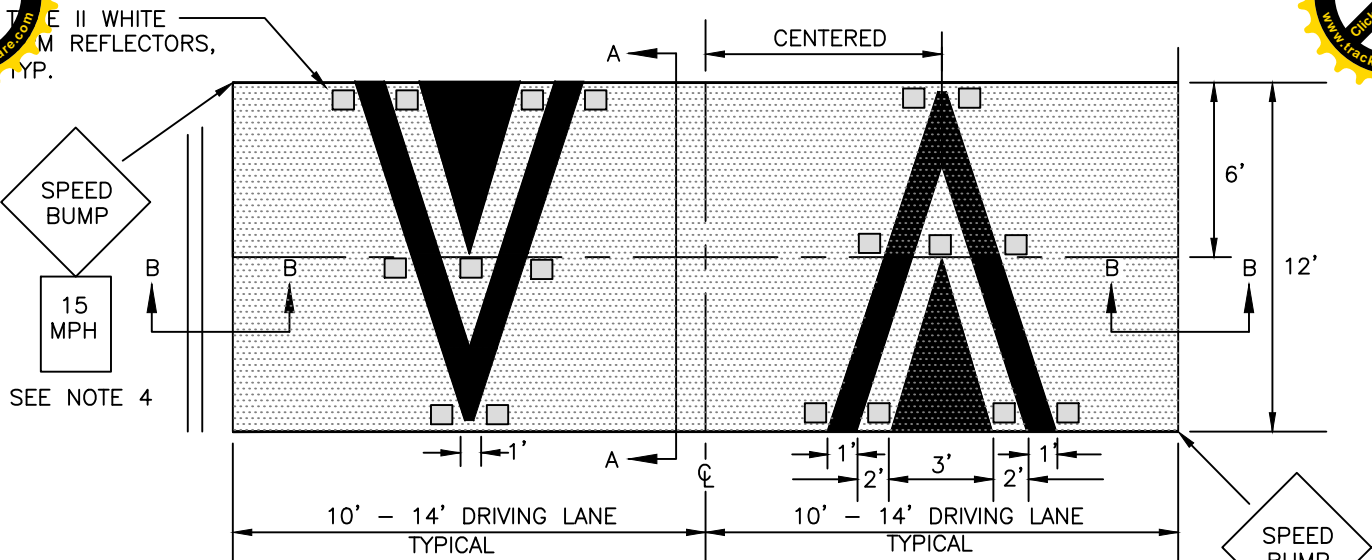
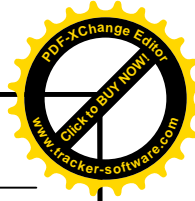

MARKING & SIGNING DETAIL

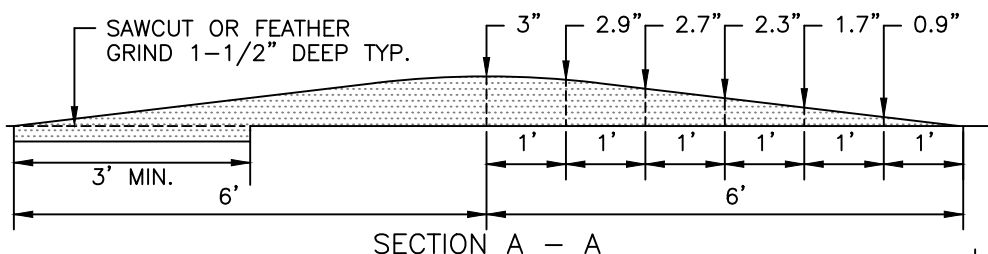

SPEED BUMP SIGN
30" X 30" W/6"
SERIES C LETTERS

15 MPH

15MPH ADVISORY
PLAQUE W13-1,
18" X 18"

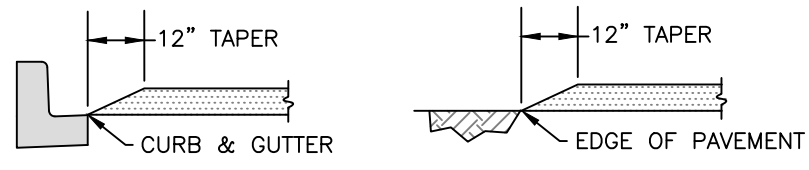

SECTION B - B

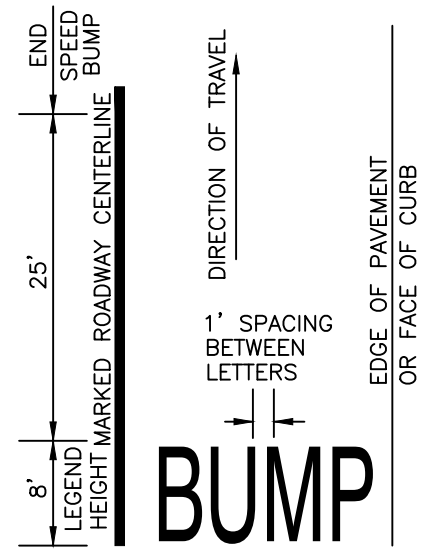

NOTES:

1. SAWCUT OR FEATHER GRIND TO KEY IN SPEED BUMP. SEE SECTION A-A.
2. SIGN LOCATIONS SHALL BE VERIFIED BY THE ENGINEER PRIOR TO INSTALLATION.
3. SPEED HUMP CHEVRON MARKING SHALL BE THERMOPLASTIC, HEAT FUSED PREFORMED, 90 MIL. OR EQUAL APPROVED BY THE ENGINEER.
4. FOR A SERIES OF SPEED BUMP IN CLOSE PROXIMITY, THE ADVISORY SPEED PLAQUE MAY BE ELIMINATED ON ALL BUT THE FIRST SPEED BUMP SIGN IN THE SERIES FOR EACH DIRECTION OF TRAVEL.

NOTE:

1. BUMP MARKING SHALL BE THERMOPLASTIC, HEAT FUSED PREFORMED, 90 MIL. OR APPROVED EQUIVALENT

TYPICAL BUMP MARKING

 <p>CITY OF MERCER ISLAND STANDARD DETAILS TRAFFIC</p>		
<p>SPEED BUMP</p>		
12/8/2015	NO SCALE	TR-15

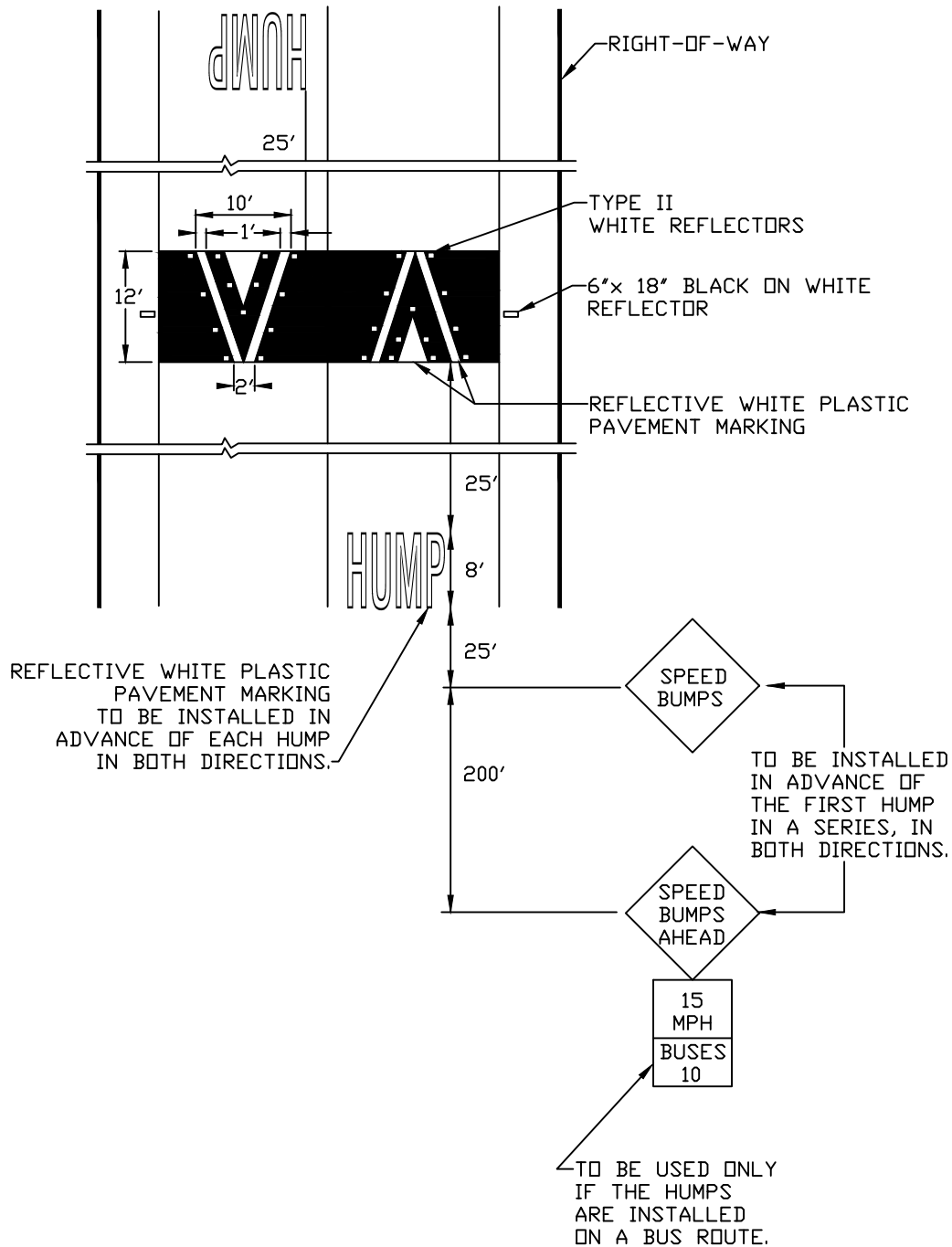
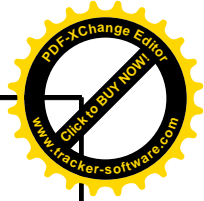
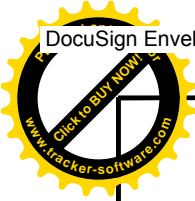

SIGN SPECIFICATIONS

1. SIGNS SHALL BE INSTALLED IN ACCORDANCE WITH THE M.U.C.T.D. AND FOLLOWING DETAILS.
2. "SPEED BUMPS" AND "SPEED BUMPS AHEAD" SHALL BE 24" x 24" BLACK ON YELLOW SCOTCHLIGHT ON 14 GAGE ALUMINUM.
3. ADVISORY SPEED SIGNS SHALL BE 18" x 18" BLACK ON YELLOW, SCOTCHLIGHT ON 16 GAGE ALUMINUM.
4. SIGN POST SHALL BE 4" x 4" x 12' CEDAR OR PRESSURE TREATED, TIMBER POSTS, WITH TACHLOROPHENDL AND PAINTED WITH 2 COATS OF OLYMPIC "NEW BARK" STAIN.

	<p>CITY OF MERCER ISLAND</p> <p>STANDARD DETAILS</p> <p>TRAFFIC</p>	
	<p>SPEED HUMP</p> <p>MARKING DIAGRAM</p>	
1-1-2000	NO SCALE	TR-15

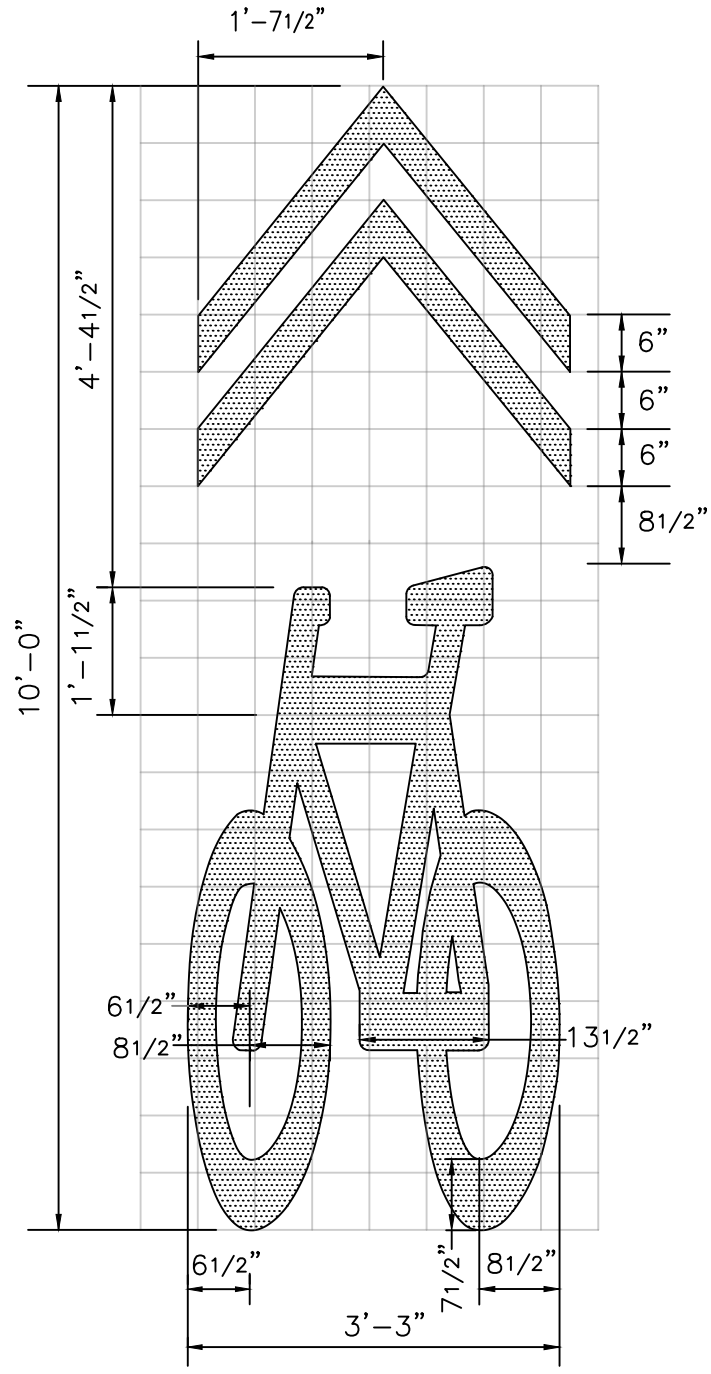
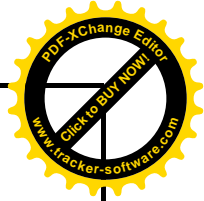
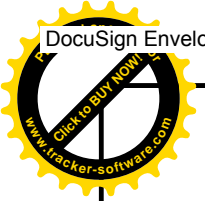

SHARROW SHARED LANE DETAIL

NOTES:

1. BIKE MARKINGS SHALL COMPLY WITH MUTCD STANDARDS.
2. ALL ROUNDED CORNERS SHALL HAVE A 1" RADIUS.
3. MATERIALS SHALL BE 90 MIL. THERMOPLASTIC OR APPROVED EQUIVALENT.
4. PLACEMENT AND ADJUSTMENTS TO DIMENSIONS SHALL BE APPROVED BY THE ENGINEER.

	<p>CITY OF MERCER ISLAND STANDARD DETAILS TRAFFIC</p>	
	<p>BICYCLE SHARED LANE DETAIL "SHARROW"</p>	
2-11-2016	NO SCALE	TR-16

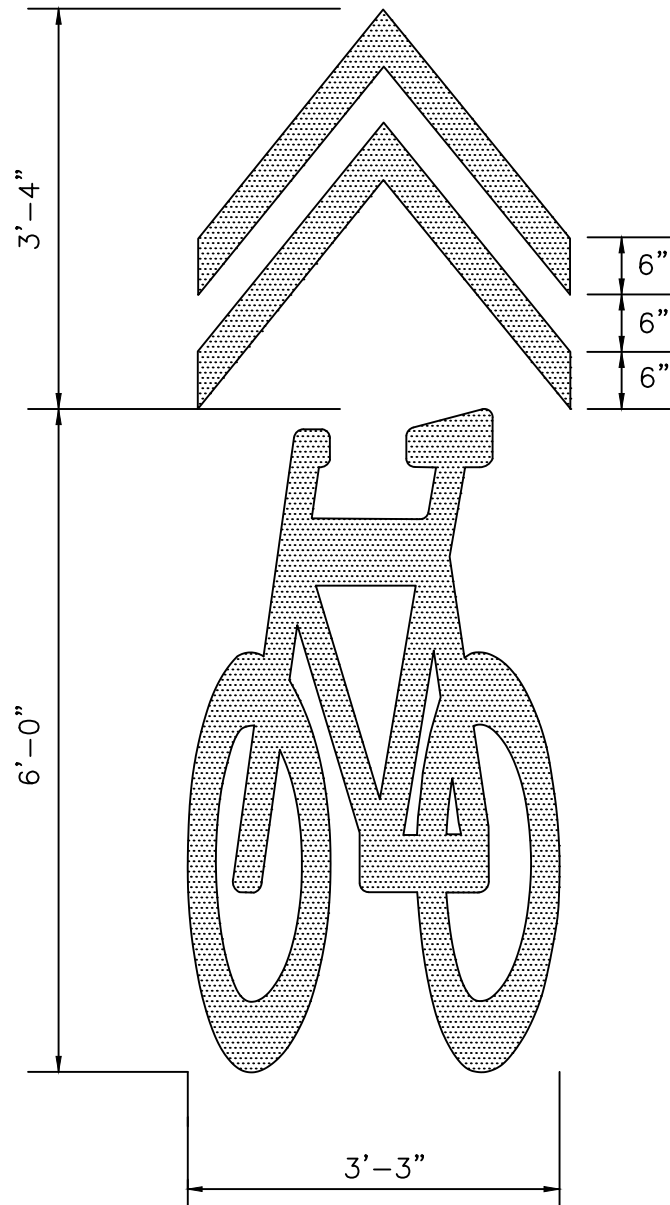
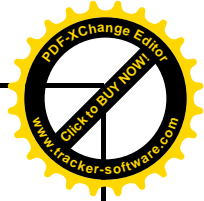
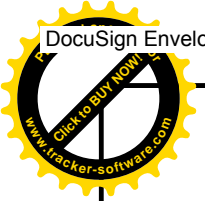

SHARROW SHARED LANE DETAIL

NOTES:

1. BIKE MARKINGS SHALL COMPLY WITH MUTCD STANDARDS.
2. ALL ROUNDED CORNERS SHALL HAVE A 1" RADIUS.
3. MATERIALS SHALL BE 90 MIL. TYPE B - PRE-FORMED FUSED THERMOPLASTIC (PER WSDOT STANDARD SPEC 9-34.3(2)) OR APPROVED EQUIVALENT.
4. PLACEMENT AND ADJUSTMENTS TO DIMENSIONS SHALL BE APPROVED BY THE ENGINEER.

	CITY OF MERCER ISLAND STANDARD DETAILS TRAFFIC	
	BICYCLE SHARED LANE DETAIL "SHARROW"	
9-19-2017	NO SCALE	TR-16